

# CIRANDA DAS

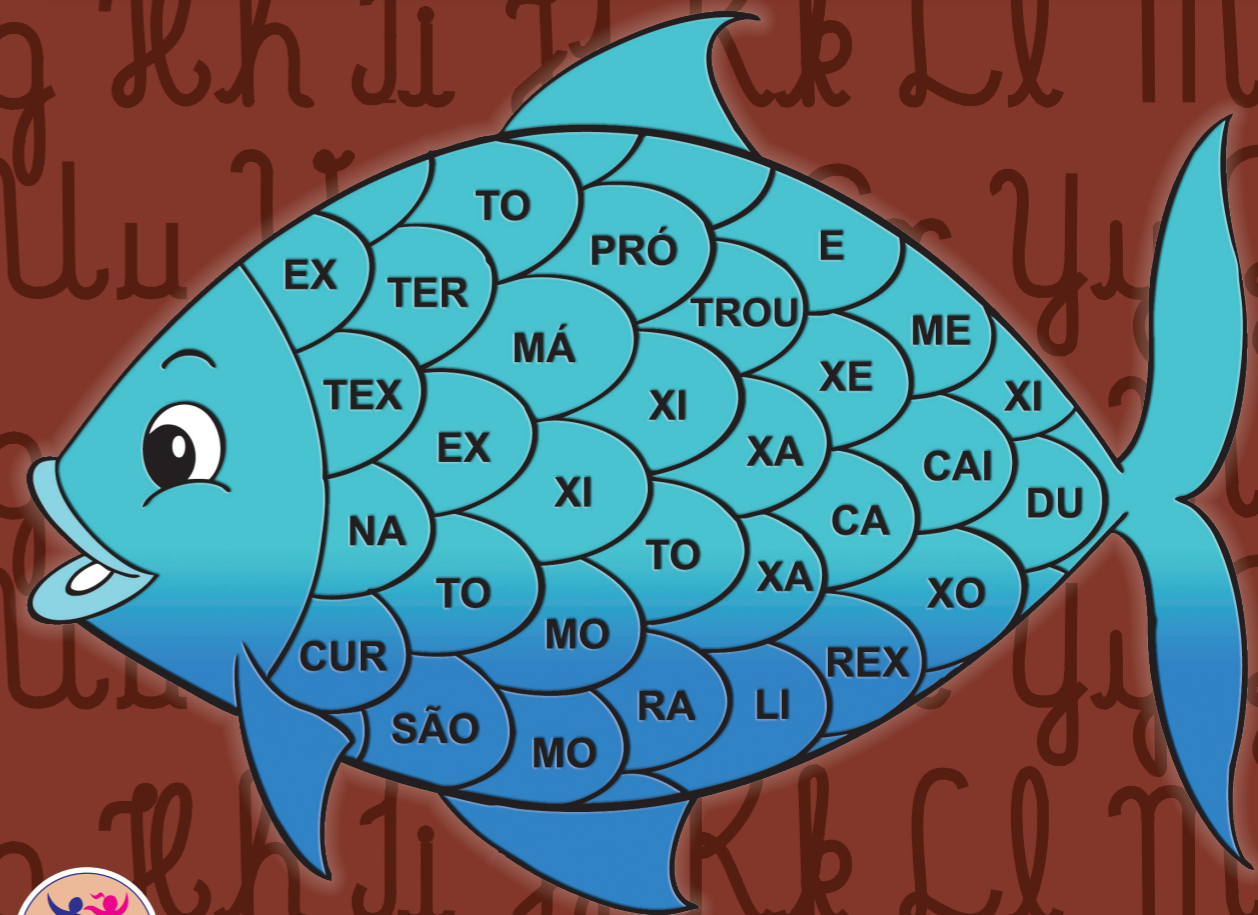

A coleção “CIRANDA DAS SÍLABAS” é composta por seis volumes, organizados em lições que apresentam atividades seqüenciais. Nos volumes 1 e 2, as lições envolvem o trabalho com vogais e consoantes, facilitando o aprendizado do alfabeto. Os demais volumes estão voltados à sistematização das famílias silábicas, permitindo, dessa maneira, que o professor avalie sistematicamente os avanços de seus alunos, fazendo intervenções adequadas ao perceber que algum aluno não está aprendendo de forma satisfatória.

Ruth Rozendo Caputo



Ciranda Cultural  
[www.cirandacultural.com.br](http://www.cirandacultural.com.br)



Ciranda Cultural

Volume 6

## PIRULITO

PIRULITO QUE BATE, BATE

PIRULITO QUE JÁ BATEU.

QUEM GOSTA DE MIM É ELA,

QUEM GOSTA DELA SOU EU.

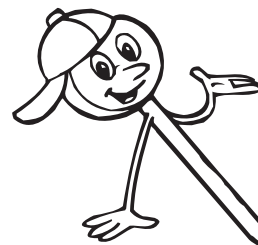

(CD *As mais Belas Cantigas de Roda*.  
Ciranda Cultural, pág. 13)

PIRULITO

pirulito

pirulito

LEIA AS PALAVRAS E CIRCULE AS SÍLABAS COM **R-BRANDO**.

careta

coroa

jacaré

MARA

pirulito

PARANÁ

MARINA

CARAPICUÍBA

VERA

MARIA

oreia

PARÁ

peru

ARISCO

coruja

GAROTO

arame

POMAROLA

peneira

peruca

GATORADE

OBSERVE QUE AO PRONUNCIAR ESSAS PALAVRAS O  
SOM DA LETRA **R** É DIFERENTE; DIZEMOS QUE É O SOM  
DO **R-BRANDO**. A SÍLABA COM **R-BRANDO**  
SEMPRE ESTARÁ ENTRE VOGAIS.

CIRCULE AS SÍLABAS COM **R** (BRANDO),  
NAS PALAVRAS ABAIXO.

BARATA	SURURU	CARETA	XÍCARA
JURURU	CARETA	CANÁRIO	COROA
XAROPE	LOURO	MARIDO	MADEIRA
MARIA	CARIOCA	SIRI	TOURO
FARELO	MORENA	PERUCA	AREIA
PIRULITO	BARÃO	AMORA	POLEIRO
JACARÉ	PERU	NAMORADO	PAREDE

COPIE AS PALAVRAS, SEPARANDO-AS EM GRUPOS,  
DE ACORDO COM AS SÍLABAS **RA** - **RE** - **RI** - **RO** - **RU**.

RA		RE	
		RI	
RO		RU	

COMPLETE AS PALAVRAS COM AS  
SÍLABAS **RA** - **RE** - **RI** - **RO** - **RU**.

CA		ME	LO
BA		TA	
A		ME	
PÊ			
XÍ	CA		

PE		RE	CA
PA		DE	
MO		NA	
FA		LO	
CA		TA	

PE		QUI	TO
SI			
MA		DO	
CA		O	CA
QUE		DA	

OU			
FA		FA	
FU			
GA		TA	
XA		PE	

U		BU	
SU		RU	
PE		CA	
CO		JA	
JU		RU	

JUNTE AS SÍLABAS E FORME PALAVRAS.

A — [ ] — ME —  
 PÊ — [ ] —  
 BA — RA — TA —  
 PI — [ ] — NHA —  
 PI — [ ] — TA —

QUE — [ ] — DO —  
 SI — [ ] —  
 FE — [ ] — RI — A-DO —  
 PE — [ ] — GO —  
 CO - LO - [ ] — DO —

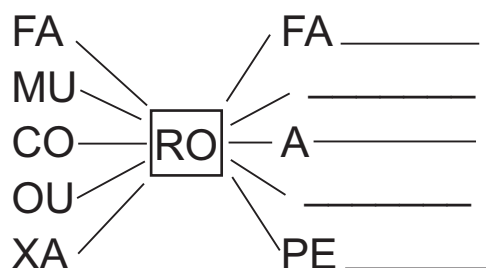

LEIA AS PALAVRAS E FORME OUTRAS  
COM AS SÍLABAS EM DESTAQUE.

PIÃO - PÊRA - CARETA

--

PENEIRA - SIRI - AGORA

--

CARECA - AMARELO - BARATA

--

FARELO - GAROTA - FARO

--

PENTE - BESOURO - BARATA

--

AVIÃO - BARATA - PÊRA

--

ORDENE AS SÍLABAS E ESCREVA AS PALAVRAS.

RI	FE	DO	A

TO	GARO

MO	NA	DO	RA

PE	CA	RE	RE

MA	A	LO	RE

TA	RABA

RE	CA	CA

RI	XE	FE

OBSERVE O MODELO E COMPLETE.

PÉ DE GOIABA É GOIABEIRA.

PÉ DE CAJU É \_\_\_\_\_

PÉ DE ABACATE É \_\_\_\_\_

PÉ DE PÊRA É \_\_\_\_\_

PÉ DE MAÇÃ É \_\_\_\_\_

PÉ DE LARANJA É \_\_\_\_\_

PÉ DE COCO É \_\_\_\_\_

TROQUE A PRIMEIRA LETRA DA PALAVRA **CARA**  
E FORME OUTRAS PALAVRAS.

CARA       ARA           

DEPOIS, TROQUE A TERCEIRA LETRA DA PALAVRA  
**CARA**, PARA FORMAR PALAVRAS DIFERENTES. EXPERIMENTE,  
POR EXEMPLO, A LETRA **S**, QUE FORMARÁ: **CASA**.

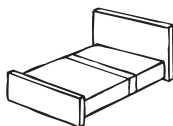
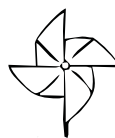

COMPLETE AS FRASES COM OS NOMES DOS ANIMAIS.

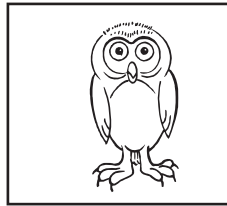
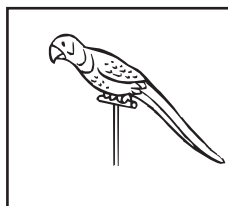
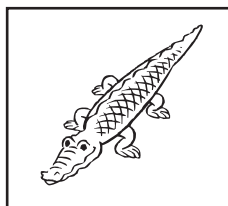
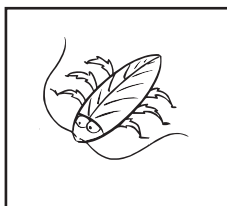

A  É UM ANIMAL DE VIDA NOTURNA.

O  É UMA AVE PEQUENA.

O  MORA NO RIO.

A  VIVE NA SUJEIRA.

A  É TODA COLORIDA.

MARIA VÊ A ARARA, A CORUJA E O .

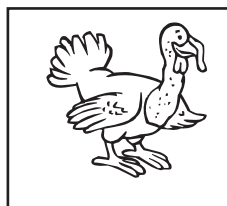

ESCREVA CADA DUPLA DE PALAVRAS NOS QUADRINHOS, SEPARANDO-AS EM SÍLABAS.

⑤ XAROPE, BESOURO

② URUBU, BIRUTA

⑥ NAMORADO, PENEIRA

③ ARAME, BARATA

④ PAREDE, CARETA

① PENEIRA, LADEIRA

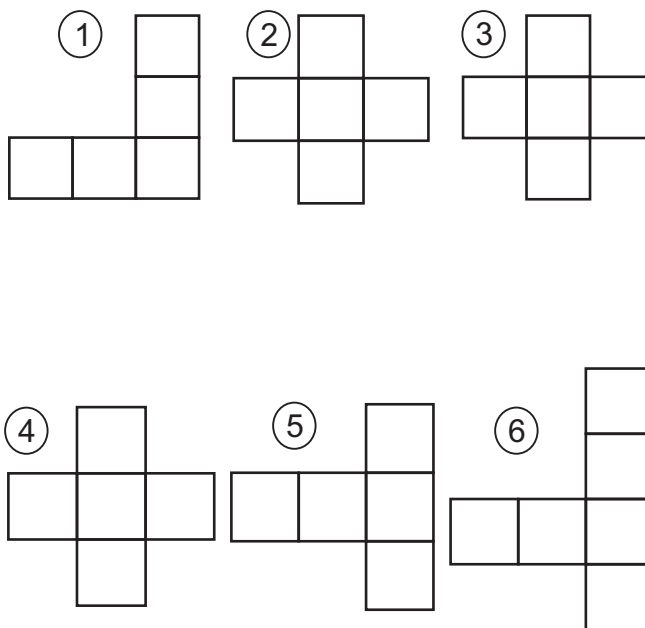

CAÇA - PALAVRAS SILÁBICO

ZA	U	CI	VA	CA	SA	VI
XA	RU	ÇA	PE	RE	RE	CA
QUA	BU	CA	SE	TA	NO	BI
PE	JA	CA	RÉ	BA	FA	PI
RU	SI	NA	WA	VE	CO	RU
XO	CO	MO	BO	FE	LO	LI
A	MO	RA	ZO	SI	RI	TO
QUE	MU	DO	CA	VU	DA	SU
SO	FI	XA	RO	PE	FO	VO

PERERECA  
 XAROPE  
 AMORA  
 PIRULITO  
 SIRI  
 URUBU  
 PERU  
 NAMORADO  
 CARO  
 CARETA  
 COLORIDA  
 JACARÉ

### A CARROCINHA

A CARROCINHA LEVOU  
TRÊS CACHORROS DE UMA VEZ (2X)  
TRÁ, LÁ, LÁ  
QUE GENTE É ESSA?  
TRÁ, LÁ, LÁ, QUE GENTE MÁ.



(CD AS MAIS BELAS CANTIGAS DE RODA.  
CIRANDA CULTURAL, pág. 53)

CIRCULE NO TEXTO AS PALAVRAS QUE TÊM **RR**.  
COPIE AS PALAVRAS QUE VOCÊ CIRCULOU.

LEIA AS PALAVRAS.

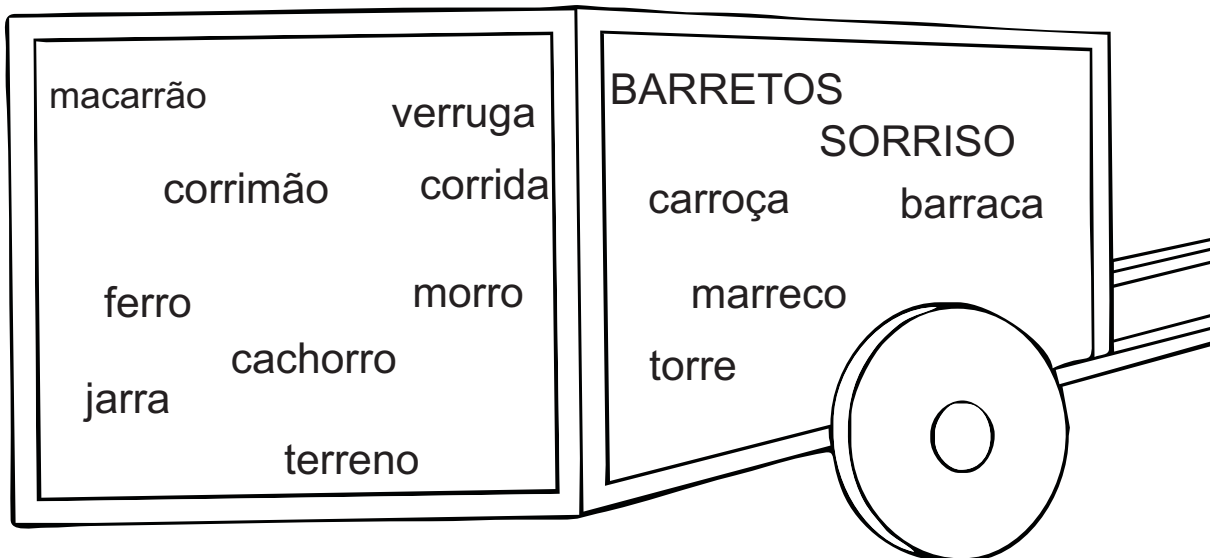

OBSERVE QUE AO PRONUNCIAR ESSAS PALAVRAS, O SOM DA

LETRA **R** É BEM FORTE. DIZEMOS QUE O **R** ESTÁ DOBRADO - **RR**.

AS LETRAS **RR** SEMPRE ESTARÃO ENTRE AS VOGAIS.



JUNTE AS SÍLABAS DE ACORDO COM OS NÚMEROS E ESCREVA AS PALAVRAS.

COR <sub>1</sub>	CHOR <sub>2</sub>	RE <sub>3</sub>	GAR <sub>4</sub>	1 - 6 - 11	16 - 10
TOR <sub>5</sub>	RI <sub>6</sub>	RO <sub>7</sub>	BAR <sub>8</sub>	9 - 7	8 - 10 - 12
CAR <sub>9</sub>	RA <sub>10</sub>	DA <sub>11</sub>	CA <sub>12</sub>	4 - 10 - 15	8 - 7
SER <sub>13</sub>	BUR <sub>14</sub>	FA <sub>15</sub>	JAR <sub>16</sub>	12 - 2 - 7	13 - 10
5 - 10 - 11				5 - 3	14 - 7

LEIA OS NOMES DOS DESENHOS E NUMERE AS PALAVRAS, DE ACORDO COM O SOM DA SÍLABA QUE TEM A LETRA **R**.



- |                                   |                                  |                                    |
|-----------------------------------|----------------------------------|------------------------------------|
| <input type="checkbox"/> CARRO    | <input type="checkbox"/> RÁDIO   | <input type="checkbox"/> CARRUAGEM |
| <input type="checkbox"/> ARARA    | <input type="checkbox"/> JARRA   | <input type="checkbox"/> RODELA    |
| <input type="checkbox"/> REI      | <input type="checkbox"/> GAROTO  | <input type="checkbox"/> PERERECA  |
| <input type="checkbox"/> BURRINHO | <input type="checkbox"/> ROSA    | <input type="checkbox"/> PIRULITO  |
| <input type="checkbox"/> RISADA   | <input type="checkbox"/> CARRETA | <input type="checkbox"/> RUA       |

FAÇA COMO O MODELO.

SERRA	
SER	RA
SERRA	

CARRO	

BARRACA		

SERROTE		

MACARRÃO		

TORRADA		

FERRÃO	

TERRA	

GORRO	

CORRIDA		

JARRA	

BETERRABA			

PINTE AS SÍLABAS QUE FORMAM O NOME DO DESENHO.

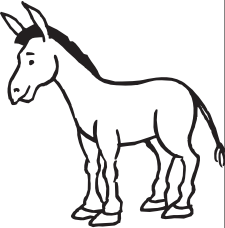

RA	BUR	BU
RO	TA	TO



BAR	PA	BA
RI	TA	GA

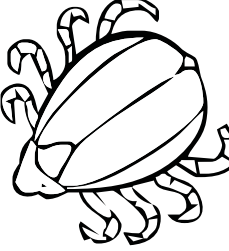

CA	CAR	RA
PA	DO	TO



SER	SE	RO
DE	TE	QUE



JAR	BUR	NO
DU	CO	RA



GA	RA	GOR
RO	BO	MA





BE	DA	TER
DE	RA	BA



NA	MA	JÃO
CAR	TAR	RÃO

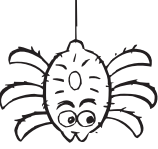



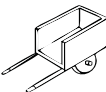





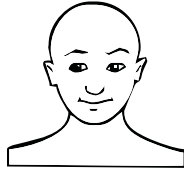

SUBSTITUA OS DESENHOS POR PALAVRAS E COPIE AS FRASES.

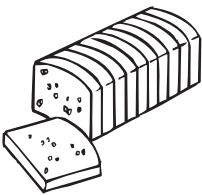
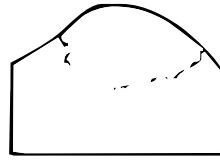
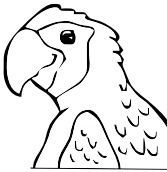
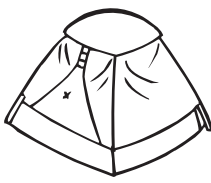
A  ARRANHA A  ; A JARRA ARRANHA A ARANHA.

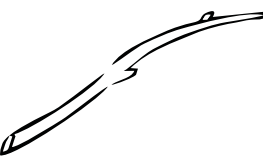
O  PUXA A  COM TERRA.

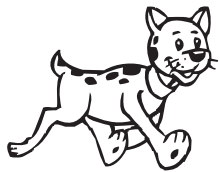
O  NÃO CONSEGUIU SUBIR O  .

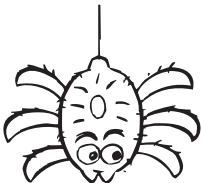
COMPLETE AS PALAVRAS COM **R** OU **RR**.

			
CA__ECA	CA__O	JA__A	BA__ATA
			
TO__ADA	MO__O	A__A__A	BA__ACA
			
ABÓBO__A	VA__A	GA__AFA	TO__E
			
CACHO__O	__ATO	A__ANHA	__OSA

SEPARE AS PALAVRAS, DE ACORDO COM AS COLUNAS.

	R NO COMEÇO	R NO MEIO	RR
RODA - MARRECO			
CARETA - RIO			
BARATA - FEIRA			
CARROÇA - CHARRETE			
RATO - RISADA			
RUA - TERRA			
ARRUAÇA - REDE			
FARINHA - CORREIO			
RÓTULO - FERRADURA			
CHARUTO - SIRENE			
ARARUTA - MACARRÃO			
ROMA - VARETA			

PINTE AS TORRADAS CUJAS PALAVRAS TÊM **RR**.

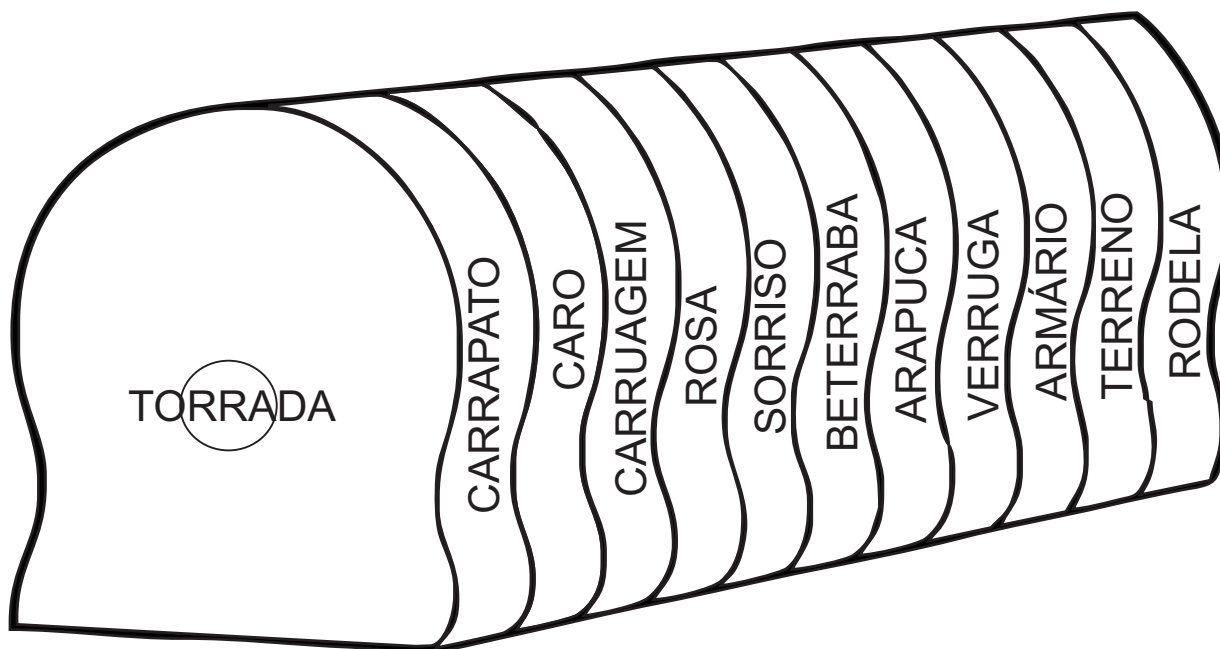

COPIE EM SEU CADERNO AS PALAVRAS QUE  
TÊM **RR** E SEPARE-AS EM SÍLABAS.

ORDENE AS PALAVRAS E ESCREVA AS FRASES.

DE É A BARRACA RUI NOVA.

DE JARRA NA BETERRABA. SUCO TEM

DE MARIA A DERRUBOU PANELA MACARRONADA.

O A CACHORRO BARRIGA. MACHUCOU

PINTE AS SÍLABAS QUE FORMAM O NOME DOS DESENHOS.  
USE COR DIFERENTE PARA CADA PALAVRA.

BAR	SER	CA	BE	RO
TOR	RA	RO	CHOR	TER
RE	JAR	CA	TE	RA
CAR	CAR	RA	MOR	BA
MA	RO	RÃO	RO	GOR
RO	FER	BUR	RO	RO

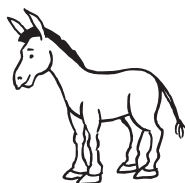
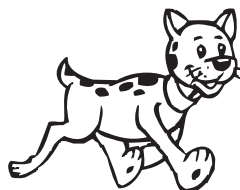
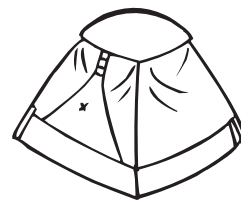
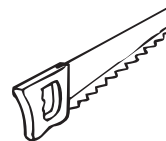

SIGA AS PISTAS E ENCONTRE AS PALAVRAS.

1- TERMINA EM **ORA** (2 PALAVRAS).

2- TEM **RR** (3 PALAVRAS).

3- TEM **RR** E É MARCA DE  
CREME DENTAL.

4- TERMINA EM **RÃO** (1 PALAVRA).

5- TEM **RR** E FICA NO ALTO  
DA IGREJA. (1 PALAVRA).

6- TERMINA EM **ARA**. (1 PALAVRA).

7- TERMINA EM **EIRA** ( 2 PALAVRAS ).

8- COMEÇA COMO RALO.  
(3 PALAVRAS).

XA	MO	XE	XI	CAR	RE	TA
ZA	RA	TOR	RE	ZI	TI	MA
RA	TA	ZE	SOR	RI	SO	CAR
TO	BA	CA	DEI	RA	QUI	RÃO
VA	CAR	WE	MA	DEI	RA	ZO
RA	RO	QUE	GUI	A	RA	RA
MO	CA	CAR	RO	ÇA	XO	ZU
XA	A	MO	RA	PI	RO	DO

COPIE AS PALAVRAS QUE VOCÊ ENCONTROU  
E SEPRE-AS EM SÍLABAS.

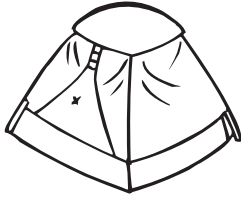

COMPLETE AS PALAVRAS ESCRREVENDO R OU RR.

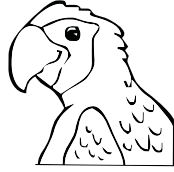

BA\_\_ACA

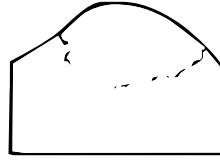

A\_\_A\_\_A



MO\_\_O



BA\_\_ATA



CA\_\_A



CA\_\_O



ABÓBO\_\_A

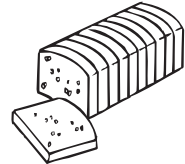

TO\_\_ADA



JA\_\_A

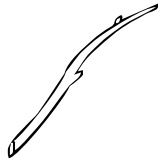

VA\_\_A



GA\_\_AFA



GI\_\_AFA



JA\_\_A\_\_ACA

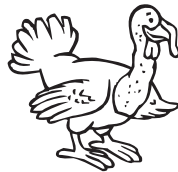

PE\_\_U

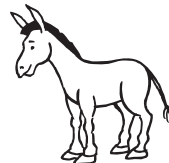

BU\_\_O



MACA\_\_ÃO



FE\_\_O



A\_\_OZ



PE\_\_UCA

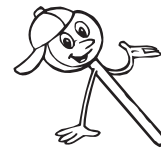

PI\_\_ULITO

AGORA, COPIE AS PALAVRAS QUE VOCÊ COMPLETOU, ESCRREVENDO-AS NO QUADRO ABAIXO.

R	_____
	_____
	_____
	_____

RR	_____
	_____
	_____
	_____

LEVE O REI ATÉ O CASTELO, COMPLETANDO AS PALAVRAS COM **R** OU **RR**. PINTE OS CAMINHOS EM CORES DIFERENTES.

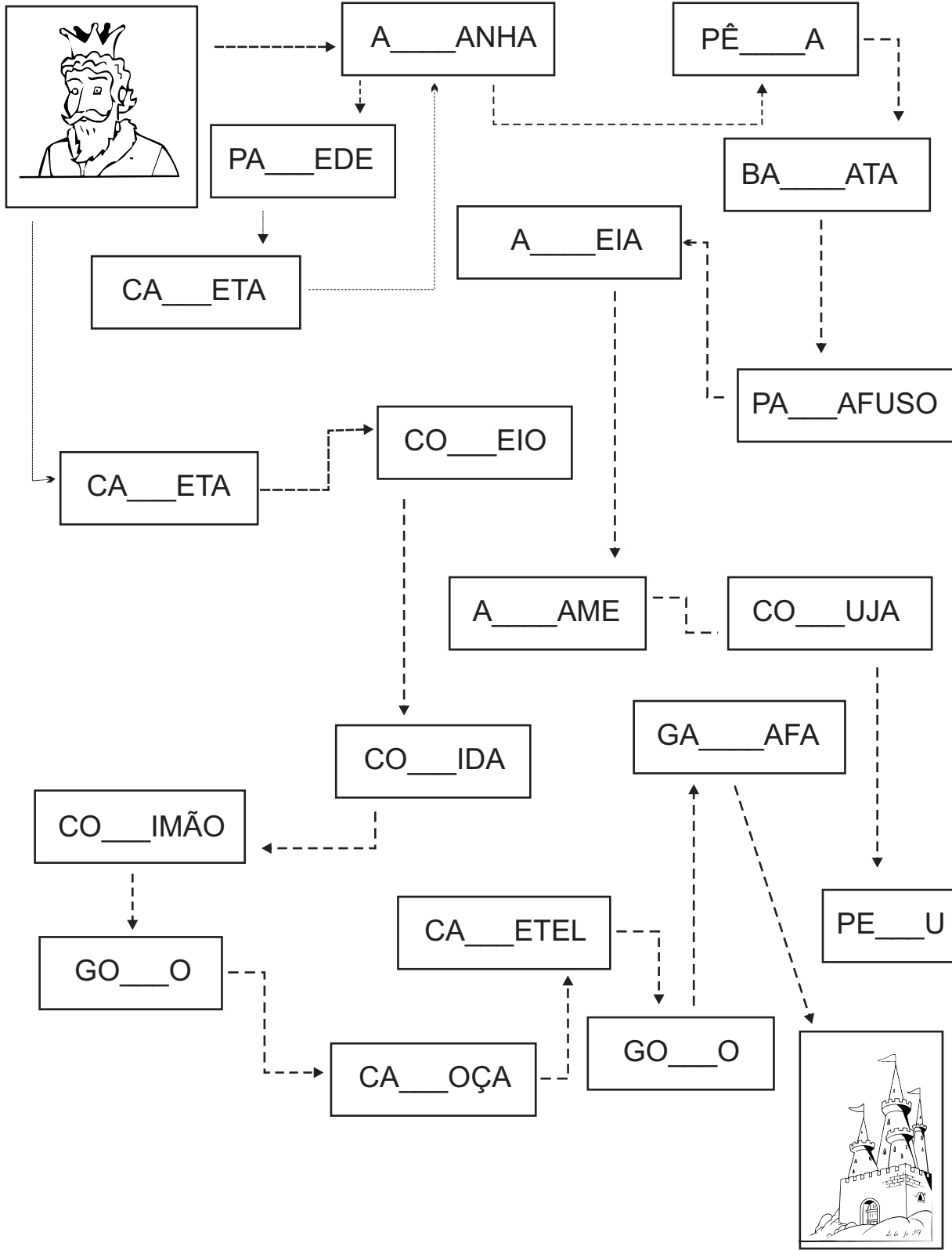



DESCUBRA O SEGREDO E TRANSFORME  
AS PALAVRAS, TROCANDO A LETRA **R**.

AREIA

ARREIA

VARA

ARRANHA

TORRA

CORA

MORO

CARRO

CARRETA

FERA

SERÁ

TERRA

a q u b A C S Z m X N O P C G V

p  
c  
v  
o  
g  
s  
a  
s  
u  
D  
q  
N  
G  
C  
h

g  
a  
S  
U  
q  
h  
z  
S  
P  
r  
D  
A  
m  
O  
V  
P  
N

### AUTODITADO

ESCREVA PALAVRAS QUE CONTENHAM A LETRA **R**, INDICADA PELOS DESENHOS.

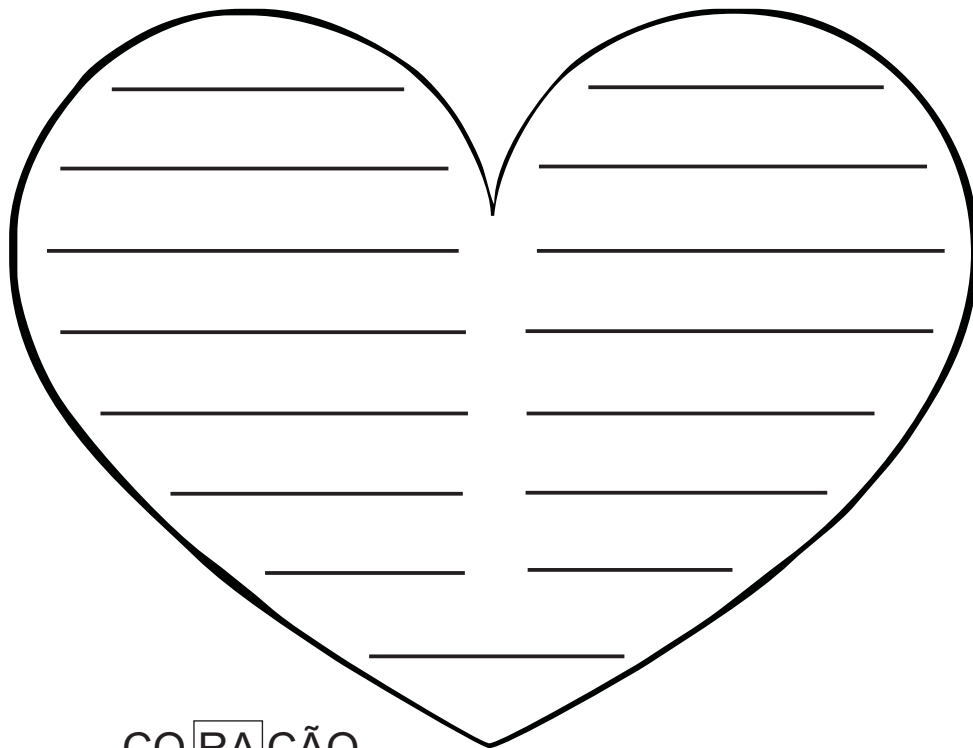

CO **R**AÇÃO

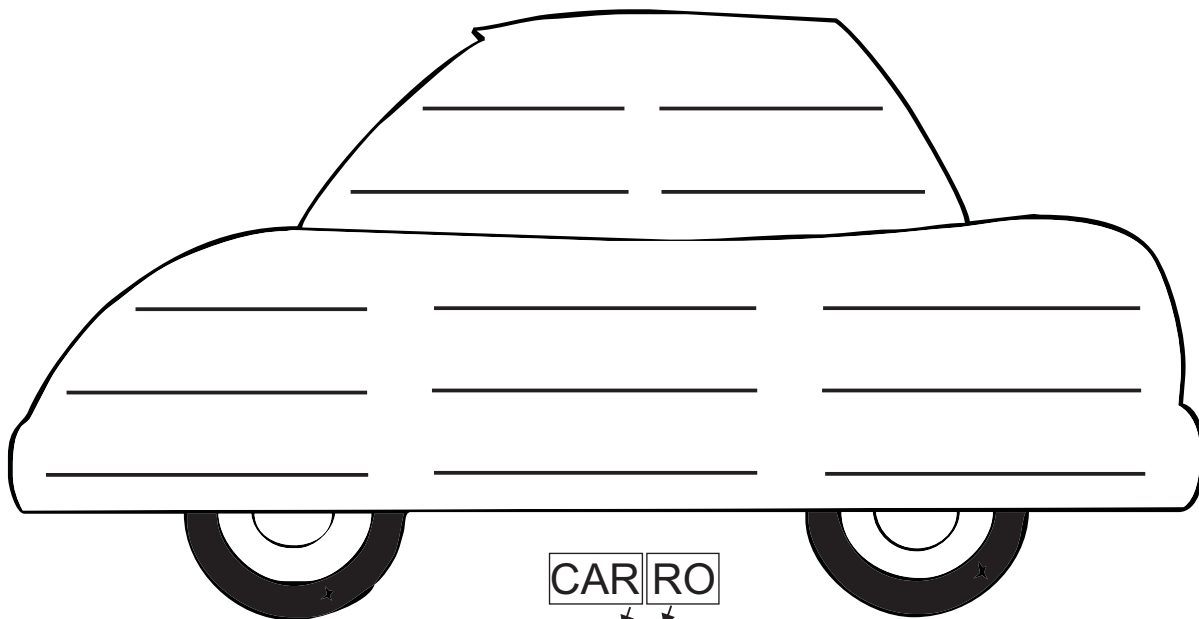

CAR **R**O  
R R

C b v H a B q A C u z m O X

a q u b A C S Z m X N O P C G V

É HORA DO DITADO.

ESCREVA AS PALAVRAS NO LUGAR INDICADO.

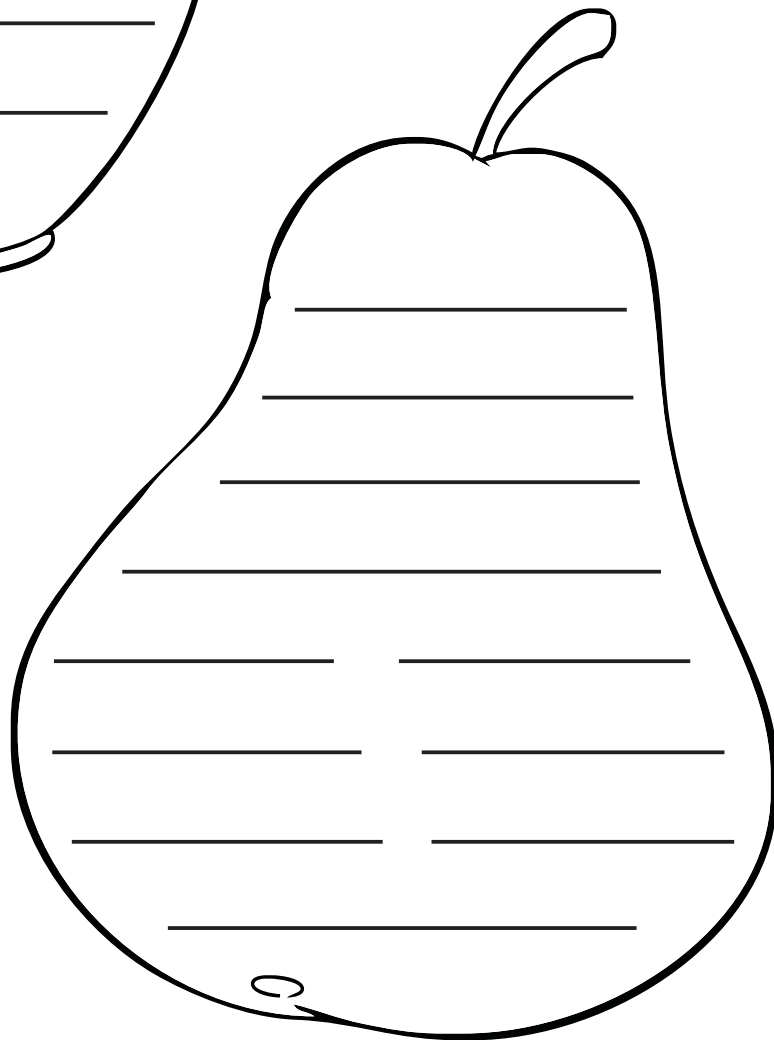
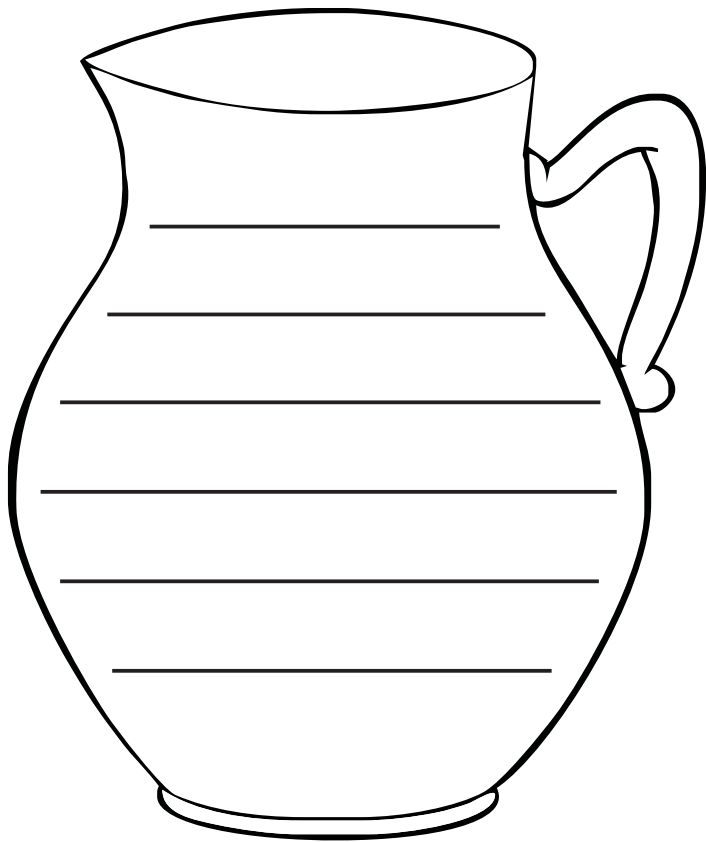

C b v H a B q A C u z m O X

## SORVETINHO, SORVETÃO

SORVETINHO, SORVETÃO

SORVETINHO DE LIMÃO.

QUEM NÃO TEM UM DINHEIRINHO

NÃO TOMA SORVETE NÃO.



(CD AS MELHORES CANTIGAS,  
CIRANDA CULTURAL, pág.77)

CIRCULE NO TEXTO A PALAVRA **SORVETINHO** E **SORVETÃO**.

COPIE AS PALAVRAS QUE VOCÊ CIRCULOU.

OBSERVE QUE A LETRA **R** ESTÁ APÓS UMA  
VOGAL. DIZEMOS QUE É O **R** PÓS-VOCÁLICO.

LEIA .

ar - er - ir - or - ur - AR - ER - IR - OR - UR

LEIA E CIRCULE AS SÍLABAS COM O **R** PÓS-VOCÁLICO.

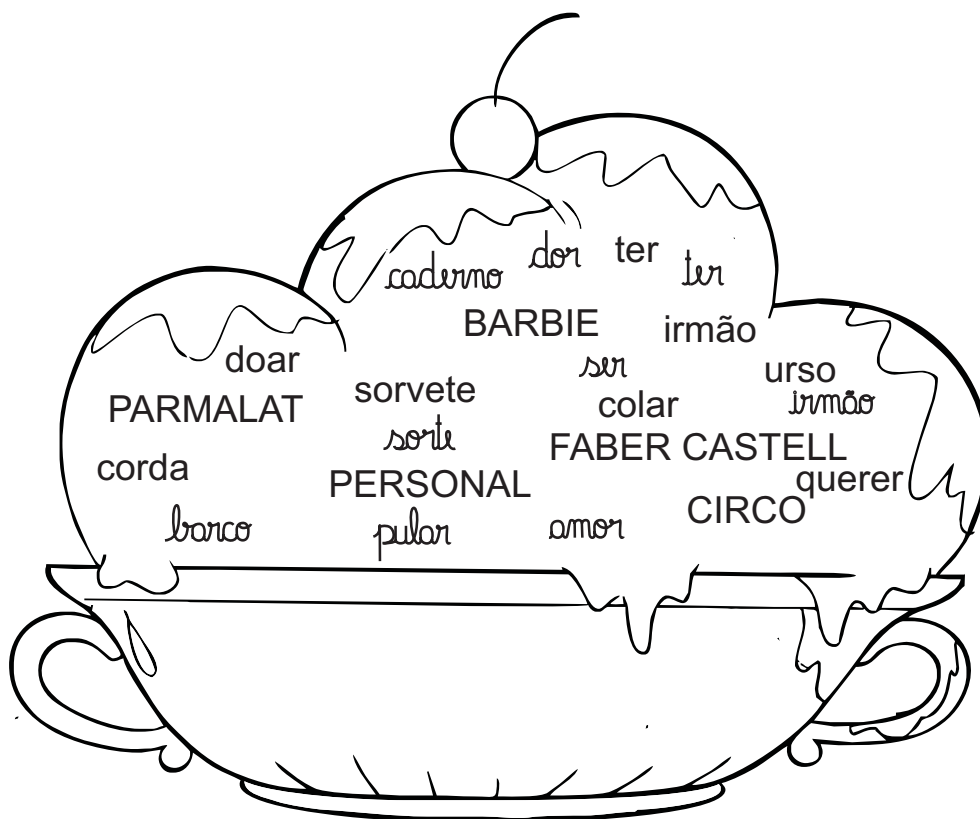

COMPLETE AS PALAVRAS, ACRESCENTANDO A SÍLABA **AR**.  
EM SEGUIDA, SEPRE-AS EM SÍLABAS.

AR \_\_\_GOLA  
 \_\_\_TISTA  
 AR \_\_\_CO  
 \_\_\_DIDO  
 \_\_\_MA  
 \_\_\_TE  
 \_\_\_QUITETO  
 \_\_\_QUIVO  
 \_\_\_VORE

JUNTE A SÍLABA INICIAL E ESCREVA AS PALAVRAS. [ ] [ ] [ ]

AR — CO \_\_\_\_\_  
 — TE \_\_\_\_\_  
 — GOLA \_\_\_\_\_

ER — MO \_\_\_\_\_  
 — GO \_\_\_\_\_  
 — VA \_\_\_\_\_

IR — MÃ \_\_\_\_\_  
 — MÃO \_\_\_\_\_

OR — QUÍDEA \_\_\_\_\_  
 — DEM \_\_\_\_\_  
 — DENA \_\_\_\_\_

UR — NA \_\_\_\_\_  
 — GE \_\_\_\_\_  
 — GENTE \_\_\_\_\_

DESCUBRA O SEGREDO E COMPLETE.

FALAR    CALA    SENTA    PARA    COME

FALAR \_\_\_\_\_

APRENDE    SABE    RI    ESTUDA    CORRIGE

APRENDER \_\_\_\_\_

LEIA E COMPLETE AS FRASES COM AS PALAVRAS ABAIXO.

MAR    CARTEIRO    COLAR    ESCREVER    CADERNO

O \_\_\_\_\_ ENTREGOU UMA CARTA PARA A IRMÃ.  
 O \_\_\_\_\_ ESTÁ CHEIO DE BARCOS.  
 MAMÃE USA UM BELO \_\_\_\_\_ NO PESCOÇO.  
 EU JÁ SEI LER E \_\_\_\_\_.  
 MARTINHA FAZ AS LIÇÕES NO \_\_\_\_\_.

PARLENDAS

**PARLENDAS**









ORDEM  
 SEU LUGAR,  
 SEM RIR,  
 SEM FALAR,  
 NUM PÉ,  
 NO OUTRO,  
 UMA MÃO,  
 NA OUTRA,  
 CRUZA OS BRAÇOS,  
 BATE PALMA,  
 DÁ UMA VOLTINHA,  
 SETE QUEDAS.

COPIE DA PARLENDAS  
 AS PALAVRAS EM QUE APARECE  
 O **R** PÓS-VOCÁLICO. ESCREVA  
 OUTRAS PALAVRAS PARECIDAS.

<input type="text"/>	<input type="text"/>
_____	_____
_____	_____
<input type="text"/>	<input type="text"/>
_____	_____
_____	_____

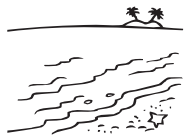
DOMÍNIO PÚBLICO

COMPLETE AS LETRAS QUE  
 FALTAM NAS PALAVRAS.

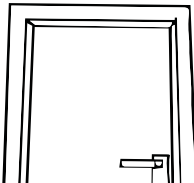
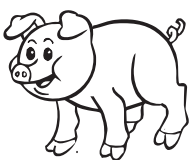
 ____SO	 G____FO	 COLH____	 S____VETE	 M____
 B____CO	 C____DA	 C____CO	 P____TA	 P____CO

LIGUE OS NOMES AOS DESENHOS CORRESPONDENTES E  
CIRCULE AS SÍLABAS QUE CONTENHAM A LETRA **R**.

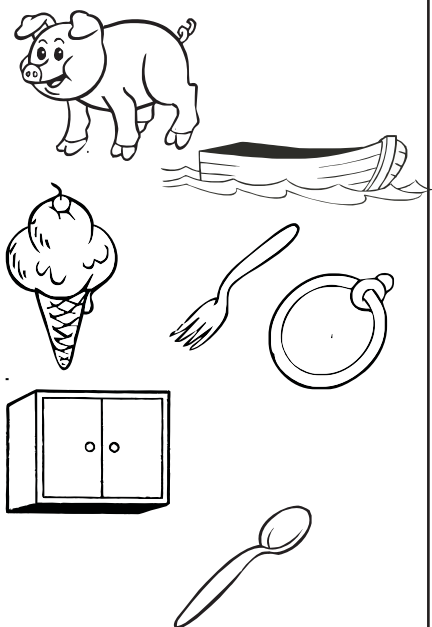

- SORVETE
- ERVILHA
- ÁRVORE
- CIRCO
- PORCO
- FLOR
- ARGOLA
- COLHER
- GARFO
- BARCO
- PORTA
- URSO
- ARMÁRIO
- CADERNO

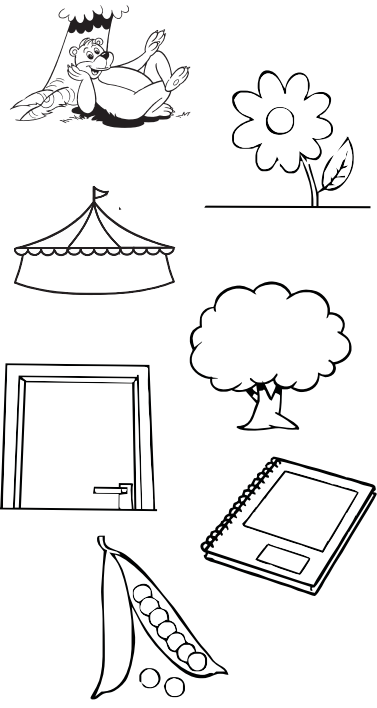

DESCUBRA A LETRA ACRESCENTADA NA PALAVRA DESTACADA E  
ACRESCENTE A MESMA LETRA, NAS OUTRAS PALAVRAS.  
ASSIM, NOVAS PALAVRAS SERÃO FORMADAS.

COPO - CORPO	LAVA -	MOTO -
FOCA -	PATO -	
PENA -	CATA -	MACA -
FADA -	AMA -	
BABA -	LAGO -	PATA -
MAÇO -	POTE -	
CALA -	MATA -	IMÃ -

SUBSTITUA OS DESENHOS POR PALAVRAS E COPIE AS FRASES.

O  ESTÁ NO PARQUE.

\_\_\_\_\_

O  É DE MORANGO.

\_\_\_\_\_

NA CASA DE ROBERTO TEM UMA  .

\_\_\_\_\_

O MAR ESTÁ CHEIO DE  .

\_\_\_\_\_

MARCELO FAZ DESENHOS NO  .

COMPLETE AS FRASES COM AS PALAVRAS ABAIXO.

GARFO - VERDURA - CARNE - ESPERTO  
ERVILHA - ARMÁRIO - DORMIR - TAMBOR

EU COMO \_\_\_\_\_ E \_\_\_\_\_.

MARTA USA O \_\_\_\_\_ PARA COMER.

MAMÃE GOSTA DE \_\_\_\_\_ À TARDE.

O GATO É \_\_\_\_\_ E ARTEIRO.

MARGARIDA COME BOLINHO DE \_\_\_\_\_.

COLOCO MINHAS ROUPAS NO \_\_\_\_\_.

O MENINO TOCA \_\_\_\_\_.

SEPARE AS SÍLABAS DAS PALAVRAS.

GARFO	

SORVETE		

MERCADO		

CADERNO		

CADERNETA			

VERMELHO		

MORTADELA			

CARTEIRO		

ABERTO		

CARNE	

TORTA	



OBSERVE OS DESENHOS E COMPLETE AS FRASES.

ARTUR GOSTA DE \_\_\_\_\_.



ERNESTO JÁ SABE \_\_\_\_\_ VIOLÃO.



MARTA NÃO SABE \_\_\_\_\_ CORDA.



A EMPREGADA SABE \_\_\_\_\_ A ROUPA.



MAMÃE FOI \_\_\_\_\_ A SALA.



MARCOS SABE \_\_\_\_\_ PETECA.



LIGUE AS SÍLABAS FORMANDO PALAVRAS E COPIE-AS AO LADO.

NA	CHAR	_____	COR	MIR	_____
CO	VAR	_____	PU	CAR	_____
MAR	DAR	_____	TO	RER	_____
LA	MER	_____	DOR	LAR	_____
SOR	RAR	_____	FA	TAR	_____
CHO	RIR	_____	CAN	ZER	_____

FORME PALAVRAS COM AS SÍLABAS DAS FRUTINHAS.

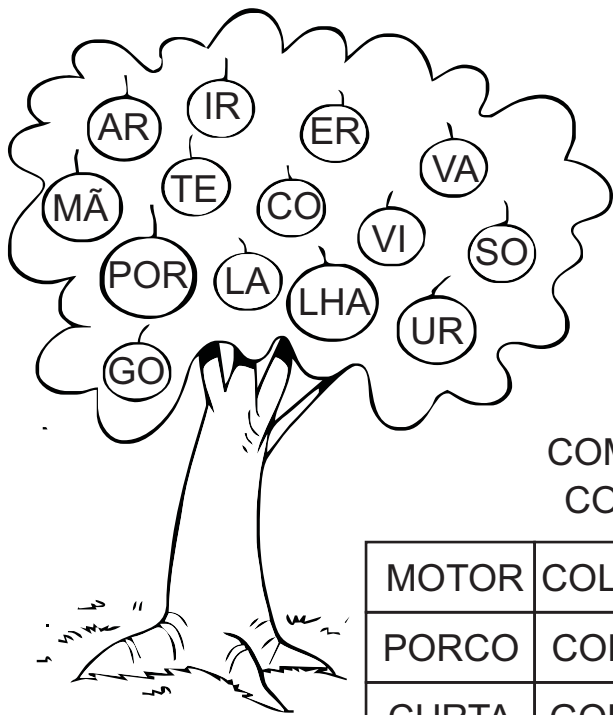

\_\_\_\_\_

\_\_\_\_\_

\_\_\_\_\_

\_\_\_\_\_

\_\_\_\_\_

COMPLETE AS EXPRESSÕES  
COM AS PALAVRAS ABAIXO.

MOTOR	COLHER
PORCO	CORDA
CURTA	GORDO
PERNA	CURVA

ROUPA NA \_\_\_\_\_  
 \_\_\_\_\_ QUEBRADA  
 CARNE DE \_\_\_\_\_  
 BARBA \_\_\_\_\_  
 MENINO \_\_\_\_\_  
 \_\_\_\_\_ DO CARRO  
 \_\_\_\_\_ DA ESTRADA  
 \_\_\_\_\_ PARA O DOCE

ESCREVA OS NOMES DOS DESENHOS.

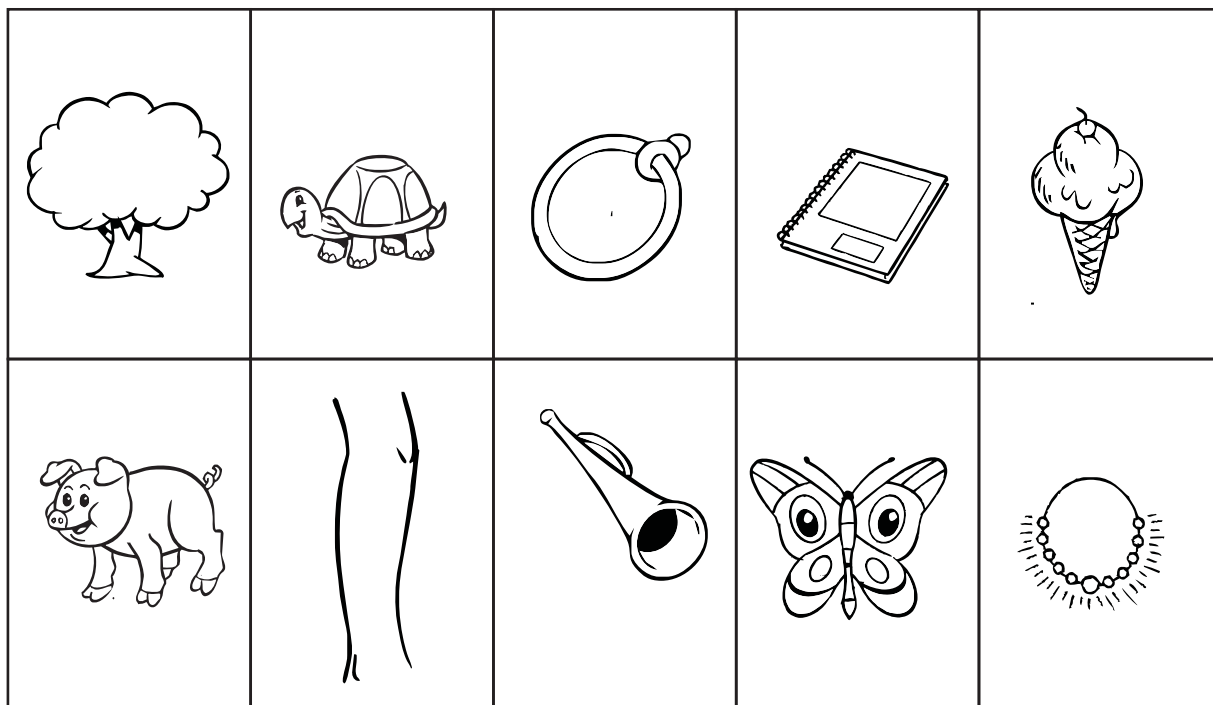

## AUTODITADO

ESCREVA PALAVRAS QUE SE  
ESCREVEM COM **R** PÓS-SILÁBICO.

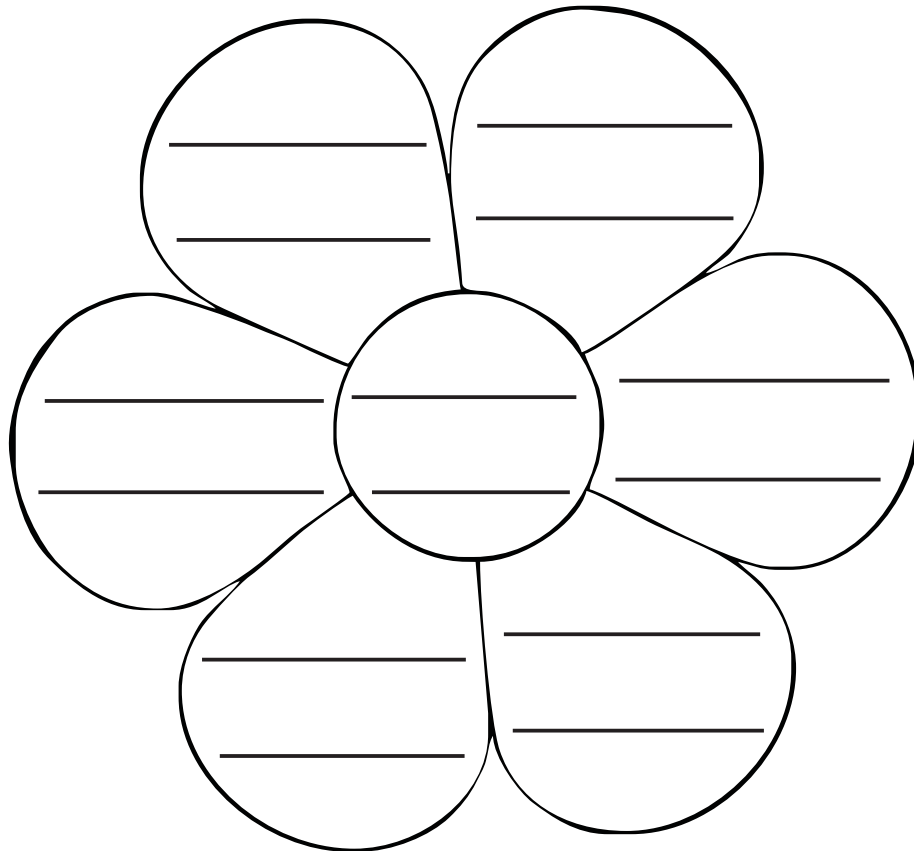

ENCAIXE AS SÍLABAS E FORME PALAVRAS.

DER	VER	OR
COR		UR
	CIR	LAR
SOR	IR	MER
MOR	BOR	BAR

BA	CA	___	NO	BO	BU	BI
BE	___	CO	DA	DI	DE	___
___	FA	___	FO	FE	FI	VE
SO	GO	GU	___	DEM	GA	TE
HA	HU	___	ME	LHO	___	CO
___	BO	LE	TA	HO	HI	A
XA	ZU	ZO	___	DA	XE	___
___	MÃO	WA	CO	___	YA	CU

a q u b A C S Z m X N O P C G V  
p  
c  
z  
o  
g  
s  
a  
s  
u  
q  
h  
z  
s  
p  
r  
D  
A  
m  
O  
V  
P  
N  
h  
C  
b v H a B q A C u z m O X

### A COBRA NÃO TEM PÉ

A COBRA NÃO TEM PÉ,  
A COBRA NÃO TEM MÃO.  
COMO É QUE ELA SOBE  
NO PÉZINHO DE LIMÃO.

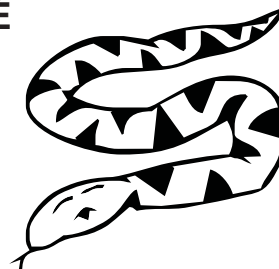

(CD AS MAIS BELAS CANTIGAS DE RODA.  
CIRANDA CULTURAL, pág.25)

CIRCULE NO TEXTO A PALAVRA **COBRA**.

COPIE.

**COBRA-**

*cobra-*

**bra-bre-bri-bro-bru-**

*bra-bre-bri-bro-bru-*

**BRA-BRE-BRI-BRO-BRU-**

*Bra-Bre-Bri-Bro-Bru-*

CIRCULE NAS SÍLABAS AS PALAVRAS COM **BR**.

<i>briga</i>	BRUNO	<i>broa</i>	BRASIL
BRENDA	<i>brasileiro</i>	BRÁULIO	BRADESCO
BOXE	<i>brejo</i>	BOM BRIL	bruxa
BRAHMA	BROTAS	BRENO	<i>broche</i>
			BRASTEMP

## OS MESES

30 DIAS TEM NOVEMBRO  
ABRIL, JUNHO E SETEMBRO.  
28 TEM SÓ UM.  
OS DEMAIS TÊM 31.



(CD AS MAIS BELAS CANTIGAS DE RODA.  
CIRANDA CULTURAL, pág. 62)

COPIE DO TEXTO AS PALAVRAS COM **BR**.

ESCREVA OUTRAS PALAVRAS COM AS SÍLABAS ABAIXO.

BRA

BRE

BRI

BRO

BRU

CIRCULE AS SÍLABAS INDICADAS ACIMA,  
NAS PALAVRAS DO QUADRO.

BRASILEIRO	BROA	CABRITO	POBRE
BRUXA	BRIGA	BREQUE	BRACELETE
BRISA	BRAÇO	BROCHE	BRILHO
BRANCO	CABRA	BREJO	BRUTO
BROTO	BRINQUEDO	TRABALHO	BRINCO
CABRITO	BRAVO	BROCA	EMBRULHO
BRASIL	BOM BRIL	BREVIDADE	BRASTEMP

ESCOLHA TRÊS PALAVRAS DO  
QUADRO ESCREVA E FORME FRASES.

COMPLETE AS EXPRESSÕES COM AS PALAVRAS ABAIXO.

BRAÇO - CABRA - BRASIL - COBRA - EMBRULHO  
BRIGA - QUEBRADO - ASSOMBRADA

LEITE DE \_\_\_\_\_

GALO DE \_\_\_\_\_

BRINQUEDO \_\_\_\_\_

PAPEL DE \_\_\_\_\_

MAPA DO \_\_\_\_\_

\_\_\_\_\_ ESQUERDO

VENENO DA \_\_\_\_\_

CASA \_\_\_\_\_

ESCREVA AS PALAVRAS E SEPRE-AS EM SÍLABAS.

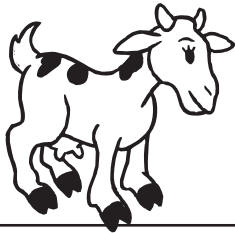



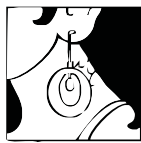





COMPLETE AS PALAVRAS  
COM **BRA BRE BRI BRO BRU**.

\_\_\_\_\_SILEIRO

\_\_\_\_\_CHE

PO\_\_\_\_\_

\_\_\_\_\_GA

\_\_\_\_\_TO

CASE\_\_\_\_\_

\_\_\_\_\_JO

\_\_\_\_\_LHO

\_\_\_\_\_ÇO

QUE\_\_\_\_DO

\_\_\_\_\_QUE

DO\_\_\_\_DURA

CA\_\_\_\_TO

\_\_\_\_\_CÓLIS

EM\_\_\_\_LHO

LIGUE AS PALAVRAS ÀS SÍLABAS CORRESPONDENTES.

BRONCA

BRA

BRILHANTE

BREJO

BRE

BRUTO

BRASIL

BRI

BRASILEIRO

EMBRULHO

BRO

BROTO

BRINQUEDO

BRU

CASEBRE

COMPLETE AS FRASES COM AS PALAVRAS ABAIXO.

CASEBRE BRAÇO BRUXA BROA  
BRINCO TRABALHADOR BRILHANTE BRASIL

BRÁULIO CAIU E QUEBROU O \_\_\_\_\_.

DEU UM VENDAVAL E O \_\_\_\_\_ FOI LEVADO PELO VENTO.

A \_\_\_\_\_ FEZ UMA POÇÃO MÁGICA.

MAMÃE FEZ \_\_\_\_\_ DE FUBÁ.

MINHA MADRINHA ME DEU UM ANEL DE \_\_\_\_\_.

MEU PAI É MUITO \_\_\_\_\_.

BRENDA GANHOU UM \_\_\_\_\_ DE PRESENTE.

A BANDEIRA DO \_\_\_\_\_ É UM SÍMBOLO NACIONAL.

a q u b A C S z m X N O P C G V  
p  
c  
c  
o  
g  
s  
a  
s  
u  
D  
q  
N  
G  
h  
C b v h a B q A C u z m o X

### O CRAVO BRIGOU COM A ROSA

O CRAVO BRIGOU COM A ROSA  
DEBAIXO DE UMA SACADA.  
O CRAVO SAIU FERIDO  
E A ROSA DESPEDAÇADA.  
O CRAVO FICOU DOENTE  
A ROSA FOI VISITAR  
O CRAVO TEVE UM DESMAIO,  
A ROSA PÔS-SE A CHORAR.



(CD CANTIGAS INFANTIS.  
CIRANDA CULTURAL. pág. 7)

CIRCULE NO TEXTO A PALAVRA **CRAVO**.

COPIE A PALAVRA

**CRAVO** -

**cravo** -

*cravo* -

**cra- cre - cri - cro - cru**

*cra-cre-cri-cro-cru*

**CRA-CRE-CRI-CRO-CRU**

*Cra-Cre-Cri-Cro-Cru*

COPIE NAS PALAVRAS AS SÍLABAS COM **CR** - **cr** .

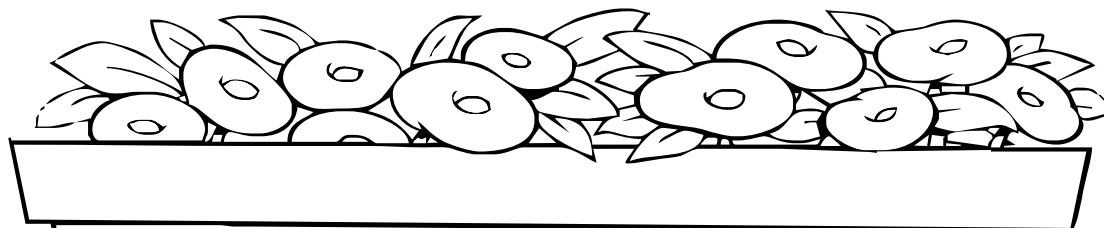

*cravo* **CRIANÇA** *critério* *croque* **CRISTO**  
*crachá* *crosta* *crochê* **CRISTINA** *crânio*  
**CRUZEIRO** *cruz* *crocante* **CRECHE**  
*crustáceo* *crina* *crítica* *crise* *crédito*



a q u b A C S z m X N O p c G V  
p  
c  
c  
v  
o  
g  
s  
a  
s  
u  
D  
q  
N  
G  
c  
h  
c b v H a B q A C u z m O X

### ALECRIM

ALECRIM,  
ALECRIM DOURADO,  
QUE NASCEU NO CAMPO  
SEM SER SEMEADO.

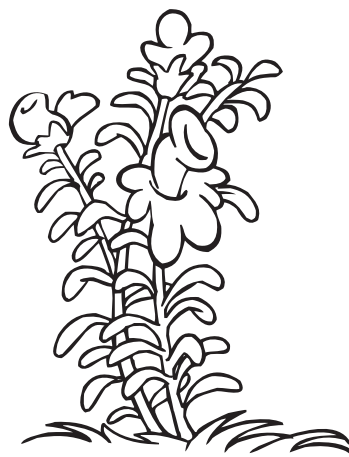

FOI MEU AMOR  
QUEM ME DISSE ASSIM:  
QUE A FLOR DO CAMPO  
É O ALECRIM.

(CD CANTIGAS INFANTIS  
CIRANDA CULTURAL, pág. 72).

CIRCULE NO TEXTO A PALAVRA **ALECRIM**.

COPIE A PALAVRA QUE VOCÊ CIRCULOU .

CIRCULE NAS PALAVRAS ABAIXO AS SÍLABAS COM **CR**.

CRAVO	CRISTAL	CRUZ	CRESCER
SACRIFÍCIO	CRESPO	RECREIO	ES CRAVO
ESCREVER	CRIANÇA	LACRE	CROCHÊ
MICRÓBIO	CROMADO	CRACHÁ	CR IADO
CRUZEIRO	CRUCIFIXO	CRIME	CROCODILO

COPIE AS PALAVRAS DE ACORDO  
COM AS SÍLABAS CIRCULADAS.

**CRA**

**CRE**

**CRI**

**CRO**

**CRU**

_____	_____	_____	_____	_____
_____	_____	_____	_____	_____
_____	_____	_____	_____	_____
_____	_____	_____	_____	_____

CIRCULE AS SÍLABAS COM **CR**  
E LIGUE A PALAVRA AO DESENHO CORRESPONDENTE.

- CRAVO
- CRUZ
- CRACHÁ
- CROCHÊ
- CRIANÇA
- CROCODILO
- CREME
- CRISTO

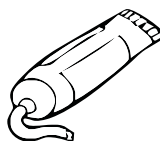
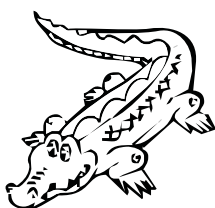
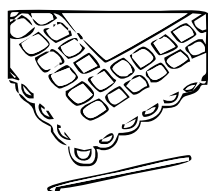
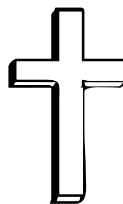
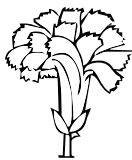

COMPLETE AS PALAVRAS COM AS SÍLABAS  
QUE CONTENHAM AS LETRAS **CR**.

\_\_\_CO  
\_\_\_CIFIXO  
\_\_\_CHÊ  
\_\_\_CODILO  
\_\_\_ME  
\_\_\_NA

\_\_\_PE  
\_\_\_CHÁ  
\_\_\_ZETA  
\_\_\_DITO  
\_\_\_VO

\_\_\_CHE  
MI\_\_\_BIO  
\_\_\_QUE  
LA\_\_\_  
ES\_\_\_VER

\_\_\_MO  
\_\_\_ME  
\_\_\_ANÇA  
SA\_\_\_FÍCIO  
\_\_\_DO  
\_\_\_ZEIRO

LIGUE AS PALAVRAS QUE SE RELACIONAM.

CRINA

GALO

CRISTA

CAVALO

CRUCIFIXO

AGULHA

CROCHÊ

CRUZ

MICRÓBIO

BRINQUEDO

CRÉDITO

PELE

CREME

DINHEIRO

CRIANÇA

DOENÇA

a q u b A C S z m X N O p c g V

### VERSINHOS

PISEI NA PEDRINHA,  
A PEDRINHA ROLOU.  
PISQUEI PRO MOCINHO,  
O MOCINHO GOSTOU.

CONTEI PRA MAMÃE,  
MAMÃE NEM LIGOU.  
CONTEI PRO PAPAI,  
CHINELO CANTOU.



DOMÍNIO PÚBLICO

CIRCULE E COPIE DO TEXTO  
A PALAVRA **PEDRINHA**.

COPIE.

**PEDRINHA**

*pedrinha*

**dra - dre - dri - dro - dru -**

*dra - dre - dri - dro - dru -*

**DRA - DRE - DRI - DRO - DRU -**

*Dra - Dre - Dri - Dro - Dru -*

CIRCULE NAS PALAVRAS AS SÍLABAS COM **DR**.

pedra	quadro	madrinha	dreno	pedregulho
padre				
empregada	madre	DRACENA	quadrado	
pedreira		draga	quadrúpede	

C b v h a B q A C u z m O X

COMPLETE AS PALAVRAS COM AS SÍLABAS DA FAMÍLIA **DR**.  
EM SEGUIDA, LIGUE OS DESENHOS.



\_\_\_\_ GÃO  
VI \_\_\_\_\_  
PA \_\_\_\_\_  
\_\_\_\_ PE  
ESPARA \_\_\_\_\_ PO  
LA \_\_\_\_\_ LHO  
VI \_\_\_\_\_ ÇA  
PE \_\_\_\_\_

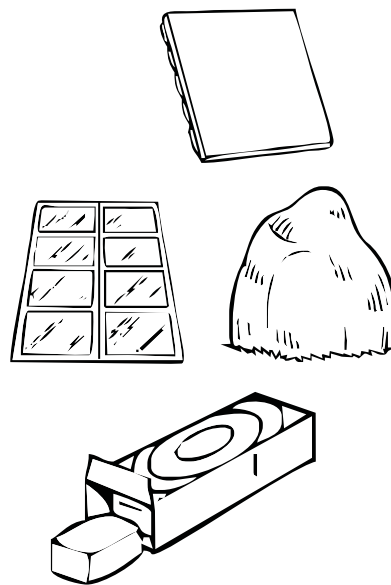

LIGUE AS PALAVRAS QUE SE RELACIONAM.

LADRILHO	CALÇADA	PADRE	BOLA
ESPARADRAPO	VIDRO	DROPE	IGREJA
VIDRAÇA	CHÃO	DRAGÃO	TEATRO
PEDRA	MACHUCADO	DRAMA	MONSTRO

LIGUE AS PALAVRAS QUE TÊM AS SÍLABAS DA FAMÍLIA **DR**.  
DEPOIS, COPIE-AS NO QUADRO AO LADO.

DROGA	MADRINHA
MADRUGADA	DRENO
PADRINHO	PEDRADA
PEDREIRA	MADRUGA
QUADRADO	DROGARIA

DRA	_____
DRE	_____
DRI	_____
DRO	_____
DRU	_____

**PAI FRANCISCO**

PAI FRANCISCO ENTROU NA RODA  
 TOCANDO SEU VIOLÃO  
 DA -RA - RÃO! DÃO! DÃO!  
 VEM DE LÁ SEU DELEGADO  
 E PAI FRANCISCO FOI PRA PRISÃO.



COMO ELE VEM TODO REQUEBRADO (2X)  
 PARECE UM BONECO DESENGONÇADO.

(CD CANTIGAS INFANTIS.  
 CIRANDA CULTURAL, pág.149)

COPIE NO TEXTO A PALAVRA **FRANCISCO**.

COPIE A PALAVRA.

**FRANCISCO-**

*Francisco-*

**fra - fre - fri - fro - fru-**

*fra - fre - fri - fro - fru-*

**FRA - FRE - FRI - FRO - FRU -**

*Fra - Fre - Fri - Fro - Fru -*

CIRCULE AS SÍLABAS QUE TÊM **FR** NAS PALAVRAS.

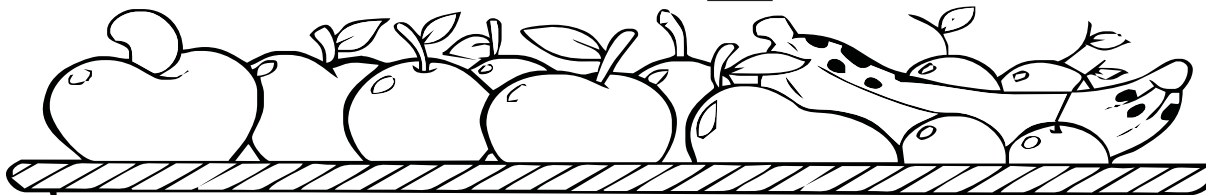

fruteira    balda    freio    frio    fraca  
 fronteira    FREVO    frutifera  
 fraque    frente    frete    fruta    freguês  
 frade    frouco    FREEZER    frigorífico    freira    frei

LEIA AS PALAVRAS, CIRCULE AS SÍLABAS COM **FR** E COPIE-AS ABAIXO, DE ACORDO COM AS SÍLABAS.

FRACO	FRENTE	FRIO	FRUTA	FRONHA
FROTA	FRADE	FRAQUE	FROUXO	FRUTARIA
FRITURA	FRUTEIRA	COFRE	FRITO	FREIO
FRONTEIRA	FRIGIDEIRA	FRANGO	FREEZER	FRUFRU

FRA	
FRE	
FRI	
FRO	
FRU	

LIGUE O DESENHO AO NOME CORRESPONDENTE.



FRITO  
FRITURA  
FRAQUE

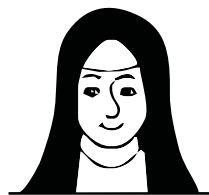

FRAQUE  
FREIRA  
FRUTÍFERA

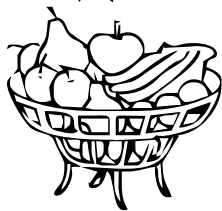

FRUTO  
FRUTEIRA  
FRIGORÍFICO

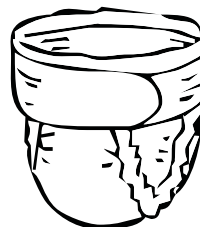

FREGUÊS  
FRALDA  
FRITADA



FRITO  
FRALDA  
FREI

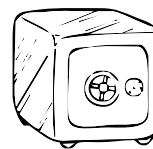

COFRE  
FRENTE  
FREIO

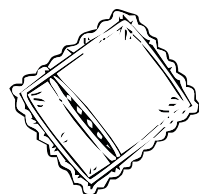

FRONHA  
FRACO  
FRETE



FRASE  
FRITURA  
FRUTA

COMPLETE AS FRASES COM PALAVRAS DAS FICHAS.

FRITA - FRUTAS - FRACO

COMI BIFE COM BATATA \_\_\_\_\_.

FRIO - FRENTE - FRANGO

O \_\_\_\_\_ ASSADO ESTÁ NO FORNO.

COFRE - AQUÁRIO - CHAVEIRO

PAULINHO PÕE MOEDAS NO \_\_\_\_\_.

FRIGIDEIRA - REFRESCO - FRAMBOESA

VOVÓ PREPAROU \_\_\_\_\_ DE CAJÚ.

FRITAS - FRIO - FRAMBOESA

JULINHA GOSTA DE SORVETE DE \_\_\_\_\_.

LIGUE AS PALAVRAS QUE SE RELACIONAM.

FRIO

CARRO

FREIO

TREMER

FRALDA

BILHETE

FRAÇÃO

BEBÊ

COMPLETE AS PALAVRAS COM **FRA FRE FRI FRO FRU**.

\_\_\_\_\_CO

\_\_\_\_\_CA

\_\_\_\_\_TEIRA

\_\_\_\_\_TE

\_\_\_\_\_IRA

\_\_\_\_\_TADA

\_\_\_\_\_NHA

\_\_\_\_\_NTEIRA

\_\_\_\_\_TA

\_\_\_\_\_TEIRO

\_\_\_\_\_SE

\_\_\_\_\_TURA

\_\_\_\_\_GORÍFICO

\_\_\_\_\_QUE

\_\_\_\_\_IO

TÁ NA HORA DE DORMIR.

TÁ NA HORA DE DORMIR  
NÃO ESPERE MAMÃE MANDAR.  
UM BOM SONO PRA VOCÊ  
E UM ALEGRE DESPERTAR.



(CD. CANTIGAS DE RODA.  
CIRANDA CULTURAL, pág. 150)

LEIA, CIRCULE E COPIE DO TEXTO A PALAVRA **ALEGRE**.

gra gre gri gro gru

gra gre gri gro gru

**GRA GRE GRI GRO GRU**

gra gre gri gro gru

CIRCULE NAS PALAVRAS AS SÍLABAS COM **GR**.

greve grama gravata grosso  
graviola GRAMADO  
GRÉCIA IGREJA GRUTA  
grande grilo GRÊMIO grude  
alegria agrião gróvida



LEIA AS PALAVRAS E LIGUE O NOME AOS DESENHOS.  
DEPOIS, COMPLETE AS EXPRESSÕES.

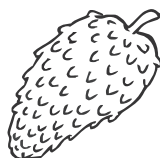
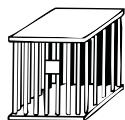
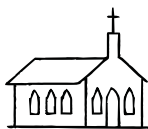

TORRE DA \_\_\_\_\_

\_\_\_\_\_ LISTRADA

\_\_\_\_\_ DA JANELA

\_\_\_\_\_ DE BENGALA

\_\_\_\_\_ DE FARINHA

\_\_\_\_\_ DA SANTA

SUCO DE \_\_\_\_\_

SALADA DE \_\_\_\_\_

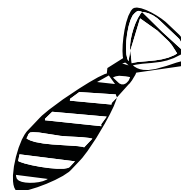

LIGUE AS PALAVRAS QUE SE RELACIONAM.

GRAVATA

CABELO

GRÁVIDA

CHURRASCO

GRAMPO

OFICINA

VINAGRE

CHOCOLATE

GRAXA

TERNO

GRANULADO

BEBÊ

GRINALDA

GRAMPO

GROSSO

FESTA

GRAMPEADOR

ORAÇÃO

ALEGRIA

BRIGA

IGREJA

NOIVA

AGRESSÃO

LIVRO

ESCREVA E SEPARE AS PALAVRAS EM SÍLABAS.

GRAVATA		

GRANDE	

VINAGRE		

GRAMPO	

GRANULADO			

GRAVIOLA			

TIGRE	

AGRIÃO		

### TRAVA-LÍNGUA

“PEDRO TEM O PEITO PRETO,  
O PEITO DE PEDRO É PRETO.  
QUEM DISSE QUE O PEITO  
DE PEDRO NÃO É PRETO  
TEM O PEITO MAIS PRETO  
DO QUE O PEITO DE PEDRO”.



RÁ - RÉ - RI - RÓ - RUA! LENICE GOMES.  
EDITORA BAGAÇO.

CIRCULE NO TRAVA-LÍNGUA AS PALAVRAS  
QUE TÊM AS SÍLABAS COM **PR**.

COPIE AS PALAVRAS QUE VOCÊ CIRCULOU.

COPIE.

pra - pre - pri - pro - pru

pra - pre - pri - pro - pru

**PRA - PRE - PRI - PRO - PRU**

pra - pre - pri - pro - pru

presunto  
proa  
presidente  
prata  
PRIMAVERA  
prova  
PRADA  
PREGO  
preto  
PRUMO

COMPLETE AS PALAVRAS COM **PRA** **PRE** **PRI** **PRO** **PRU**.

_____GO	_____SUNTO	_____ÇO
_____VA	COM_____DO	_____ÇA
_____MO	_____SENTE	_____MAVERA
_____NCESA	_____FETA	_____DENTE
_____TELEIRA	_____TARIA	_____TARIA

COMPLETE AS FRASES, COM AS PALAVRAS ABAIXO.

**PRETO**

**PRÊMIO**

**PRATO**

**PROVA**

**PROFESSOR**

TOMEI UM \_\_\_\_\_ DE SOPA.

JOÃO GANHOU UM \_\_\_\_\_.

HOJE FIZ UMA \_\_\_\_\_ DE MATEMÁTICA.

O CONTRÁRIO DE BRANCO É \_\_\_\_\_.

GOSTO DO MEU \_\_\_\_\_ DE PORTUGUÊS.

LIGUE AS PALAVRAS QUE SE RELACIONAM.

PREGO

FLORES

PRESUNTO

PRODUTOS

PROVA

MEDALHA

PRESIDENTE

ÁRVORES

PRÊMIO

ESCOLA

PRAÇA

PAÍS

PRIMAVERA

MADEIRA

PREÇO

PORCO

SEPARE AS PALAVRAS EM  
SÍLABAS E COPIE-A NOVAMENTE.

PRATO

PROFESSOR

PREGUIÇA

PREMIADO

PEDREIRA

PRETO

PROMESSA

EMPREGO

LEIA AS PALAVRAS, SEPARE-AS EM SÍLABAS E COMPLETE AS FRASES.

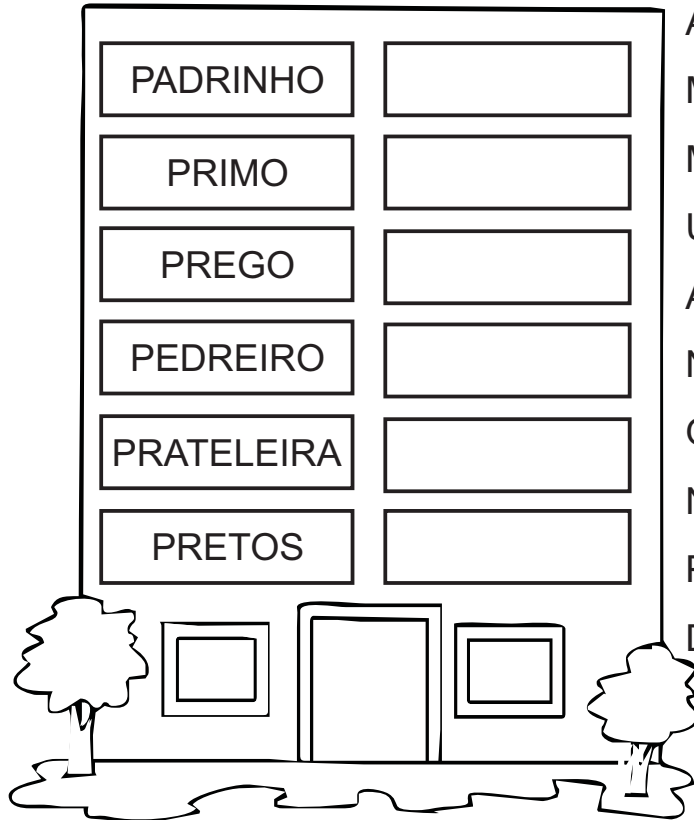

A EMPREGADA DA CASA DO  
 MEU \_\_\_\_\_ É ESPERTA.  
 MEU \_\_\_\_\_ ME CONTOU  
 UM SEGREDO.  
 A BRUXA PREGOU UM \_\_\_\_\_  
 NA VASSOURA.  
 O \_\_\_\_\_ CHAMA-SE PEDRO.  
 NA \_\_\_\_\_ TEM LOUÇAS.  
 PEDRO ENGRAXOU SEU PAR  
 DE SAPATOS \_\_\_\_\_.

JUNTE AS SÍLABAS DE ACORDO COM OS NÚMEROS E ESCREVA AS PALAVRAS.

1  
PRA

2  
PRE

3  
DO

4  
GO

5  
TO

6  
PRO

7  
GA

8  
VA

1 - 5

2 - 4

1 - 7

2 - 7

1 - 3

2 - 7 - 3

2 - 5

6 - 8

LEIA, RECORTE E COLE AS FICHAS DAS PALAVRAS,  
DE ACORDO COM AS SÍLABAS INDICADAS.

PRA	_____
PRE	_____
PRI	_____
PRO	_____
PRU	_____

COPIE AS PALAVRAS QUE VOCÊ COLOU E  
CIRCULE AS SÍLABAS COM **PR**.

PRATO	PRIMO	PRATA	PREGO
DEPRESSA	PRÉDIO	PROMOÇÃO	PRUDÊNCIA
PRATELEIRA	PRUMO	CAPRICHOS	PRATEADO
PROIBIDO	PROFESSORA	EMPREGO	PRÓXIMO
PRIMAVERA	PRUDENTE	PRIVADA	PRURIDO

### O TREM MALUCO

O TREM DE FERRO  
QUANDO SAI DE PERNAMBUCO,  
VAI FAZENDO CHIC, CHIC  
ATÉ CHEGAR NO CEARÁ.

REBOLA, BOLA,  
VOCÊ DIZ QUE DÁ, QUE DÁ.  
VOCÊ DIZ QUE DÁ NA BOLA,  
NA BOLA VOCÊ NÃO DÁ.

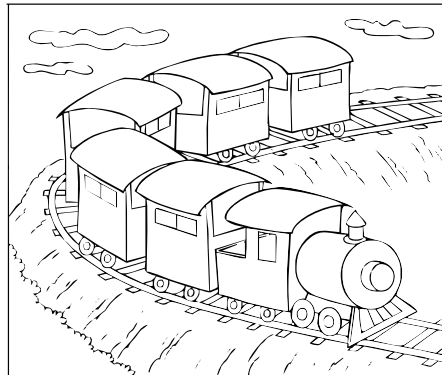

(CD AS MAIS BELAS CANTIGAS DE RODA.  
CIRANDA CULTURAL, pág.28)

CIRCULE NO TEXTO A PALAVRA **TREM**.  
DEPOIS, COPIE A PALAVRA CIRCULADA .

COPIE.

tra - tre - tri - tro - tru

tra - tre - tri - tro - tru

**TRA - TRE - TRI - TRO - TRU**

tra - tre - tri - tro - tru

CIRCULE NAS PALAVRAS AS  
SÍLABAS QUE TÊM AS LETRAS **TR**.



LIGUE OS NOMES AOS DESENHOS CORRESPONDENTES.

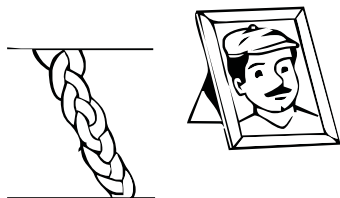
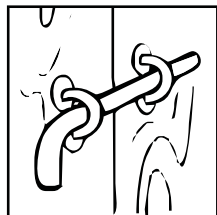
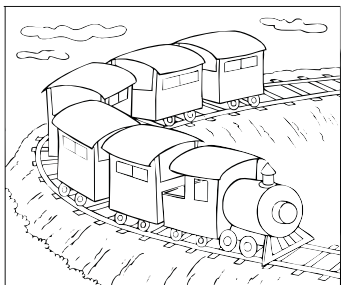

TRILHO  
 TRANÇA  
 TREM  
 TRINCO  
 TRAVESSEIRO  
 ESTRADA  
 TROVÃO  
 TRABALHO  
 RETRATO  
 TROVOADA  
 ENTRADA  
 TRÊS

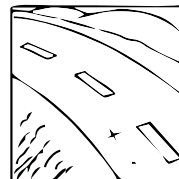
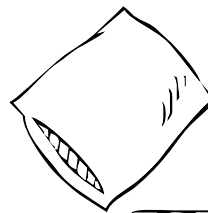

3

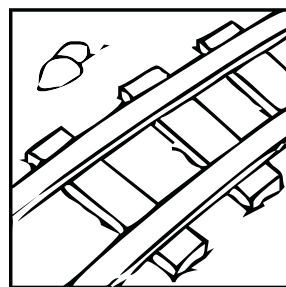

CIRCULE AS PALAVRAS PARECIDAS COM A PALAVRA **TRINCO**.

TRONCO  
 TRINCO

TRIBO  
 TRIPA

TRANÇA  
 TRAPO

TRIPÉ  
 TRILHA

LIGUE AS PALAVRAS QUE SE RELACIONAM.

TRONCO  
 TRIPA  
 TRIBO  
 TRINCO

ÍNDIO  
 PORTA  
 ÁRVORE  
 LINGÜIÇA

TRANÇA  
 TRAPO  
 TREM  
 TRIGO

TRILHO  
 FARINHA  
 RAPUNZEL  
 PANO

ESCOLHA TRÊS PALAVRAS DESTA FOLHA  
 COPIE E ESCREVA FRASE SOBRE ELAS.

**CAIXA MÁGICA DE SURPRESA.**

UM LIVRO  
É UMA BELEZA,  
É CAIXA MÁGICA  
SÓ DE SURPRESA.

UM LIVRO  
PARECE MUDO,  
MAS NELE A GENTE  
DESCOBRE TUDO.

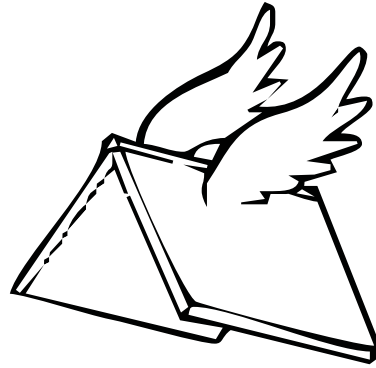

UM LIVRO  
TEM ASAS  
LONGAS E LEVES  
QUE, DE REPENTE,  
LEVAM A GENTE  
LONGE, LONGE.

CAIXA MÁGICA DE SURPRESA -  
ELIAS JOSÉ -ED. PAULINAS, 1998.

LEIA A POESIA E COPIE NO TEXTO A PALAVRA **LIVRO**.  
COPIE.

vra - vre - vri - vro

vra - vre - vri - vro

**VRA - VRE - VRI - VRO**

Vra - Vre - Vri - Vro

CIRCULE NAS PALAVRAS AS SÍLABAS COM **VR**.

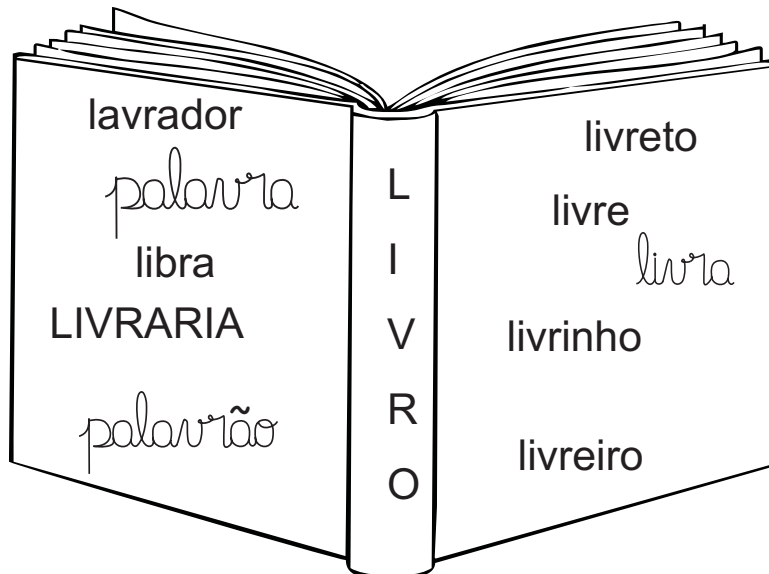



COMPLETE AS FRASES COM AS PALAVRAS DAS FICHAS

LAVADOR - LAVRADOR - LIVREIRO

O \_\_\_\_\_ LAVRA A TERRA.  
PEDRO É \_\_\_\_\_ DE CARROS

LUVA - LIVRO - LIVREIRO

CRISTINA GANHOU UM \_\_\_\_\_ do \_\_\_\_\_.

COMPLETE AS PALAVRAS COM **VRA** **VRE** **VRI** **VRO**.

LI \_\_\_\_\_                      LI \_\_\_\_\_ U                      LI \_\_\_\_\_  
LI \_\_\_\_\_ NHO                      LI \_\_\_\_\_ RIA                      PALA \_\_\_\_\_  
LI \_\_\_\_\_ IRO                      LA \_\_\_\_\_ DOR

ACRESCENTE A LETRA **R** ÀS PALAVRAS E FORME OUTRAS PALAVRAS. DEPOIS, SEPRE-AS EM SÍLABAS.

LAVA

LAVADOR

LIGUE AS PALAVRAS QUE SE RELACIONAM.

LIVRO	TERRA
LAVRADOR	ALUNO
LIVRE	PÁSSARO
PALAVRA	LIVROS
LIVRARIA	LETRAS

ADIVINHE.

QUEM É SURDO-MUDO, MAS CONTA TUDO?

(LIVRO)

DESCUBRA OUTRAS PALAVRAS,  
ACRESCENTANDO A LETRA **R**.

BOTO \_\_\_\_\_ BROTO \_\_\_\_\_

PODE \_\_\_\_\_

MAGO \_\_\_\_\_

TOPA \_\_\_\_\_

FIO \_\_\_\_\_

FEIA \_\_\_\_\_

PESO \_\_\_\_\_

TINTA \_\_\_\_\_

PEGO \_\_\_\_\_

TEM \_\_\_\_\_

BAÇO \_\_\_\_\_

BIGA \_\_\_\_\_

CAVO \_\_\_\_\_

GAMA \_\_\_\_\_

BOA \_\_\_\_\_

DAMA \_\_\_\_\_

PATO \_\_\_\_\_

FACA \_\_\_\_\_

TATO \_\_\_\_\_

BOCA \_\_\_\_\_

TIO \_\_\_\_\_

PATA \_\_\_\_\_

FEIO \_\_\_\_\_

GUDE \_\_\_\_\_

ORDENE AS SÍLABAS E ESCREVA AS PALAVRAS.

CO CRO DI LO

DA DRA PE

TAS FRI

NHA MA DRI

\_\_\_\_\_

GA MA DRU DA

MA GRA DO

\_\_\_\_\_

XA BRU RI A

PRA COM

GÃO DRA

DOR VRA LA

\_\_\_\_\_

CA BRIN RA DEI

DO QUE BRIN

\_\_\_\_\_

ZE TRE

NHA PRA CI

CO BRIN

TRE ES LA

\_\_\_\_\_

## MARCHA SOLDADO

MARCHA SOLDADO,  
CABEÇA DE PAPEL.  
QUEM NÃO MARCHAR DIREITO  
VAI PRESO NO QUARTEL.



QUARTEL PEGOU FOGO  
POLÍCIA DEU SINAL.  
ACODE, ACODE, ACODE  
A BANDEIRA NACIONAL.

(CD AS MAIS BELAS CANTIGAS DE RODA.  
CIRANDA CULTURAL, pág. 9)

CIRCULE NO TEXTO AS PALAVRAS: SOLDADO,  
PAPEL, QUARTEL, SINAL, NACIONAL.

COPIE AS PALAVRAS QUE VOCÊ CIRCULOU.

--	--	--	--	--

LEIA E COPIE AS SÍLABAS QUE TÊM O **L** PÓS-VOCÁLICO.

al - el - il - ol - ul AL - EL - IL - OL - UL

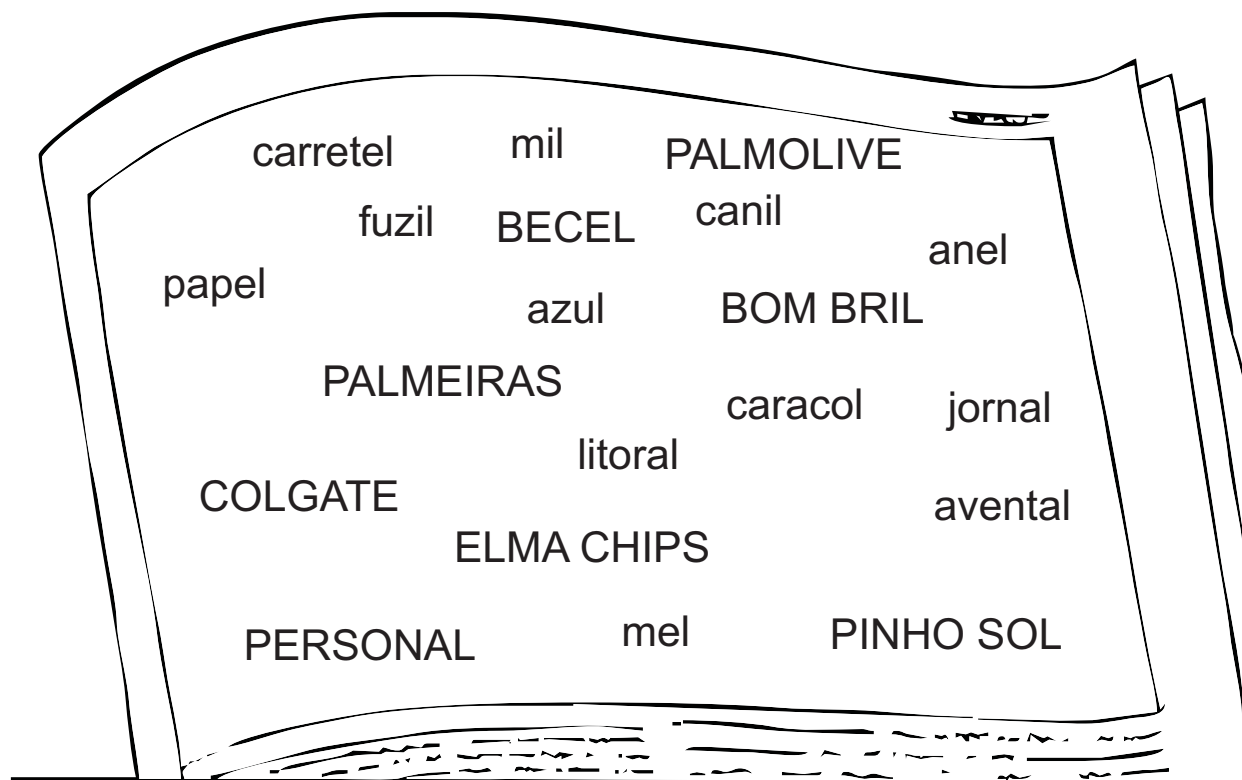

COMPLETE AS FRASES COM UMA DAS PALAVRAS DA FICHA.

FILME - BOLSA - TALCO - ANEL

MAMÃE GANHOU UMA \_\_\_\_\_ NOVA DE PRESENTE.

SOL - SINAL - ALGODÃO - ANIMAL

O LEÃO É UM \_\_\_\_\_ FERROZ.

ANEL - FUNIL - CARRETEL - BALDE

O BEBÊ PUXOU A LINHA DO \_\_\_\_\_.

FAROL - BOLSA - DEDAL - SALTO

O SAPATO DA MOÇA TEM \_\_\_\_\_ ALTO.

SINAL - SALGOU - BARRIL - BALDE

TITIA \_\_\_\_\_ DEMAIS A SALADA DO TITIO.

SEPARE AS SÍLABAS DAS PALAVRAS E COPIE-AS.

JORNAL	

SOLDADO		

CARRETEL		

BOLSA	

AUTOMÓVEL			

BALDE	

ANEL	

TÚNEL	

PAPEL	

ALFINETE			

DEDAL	

ALGODÃO		

FORME PALAVRAS COM AS SÍLABAS ABAIXO.

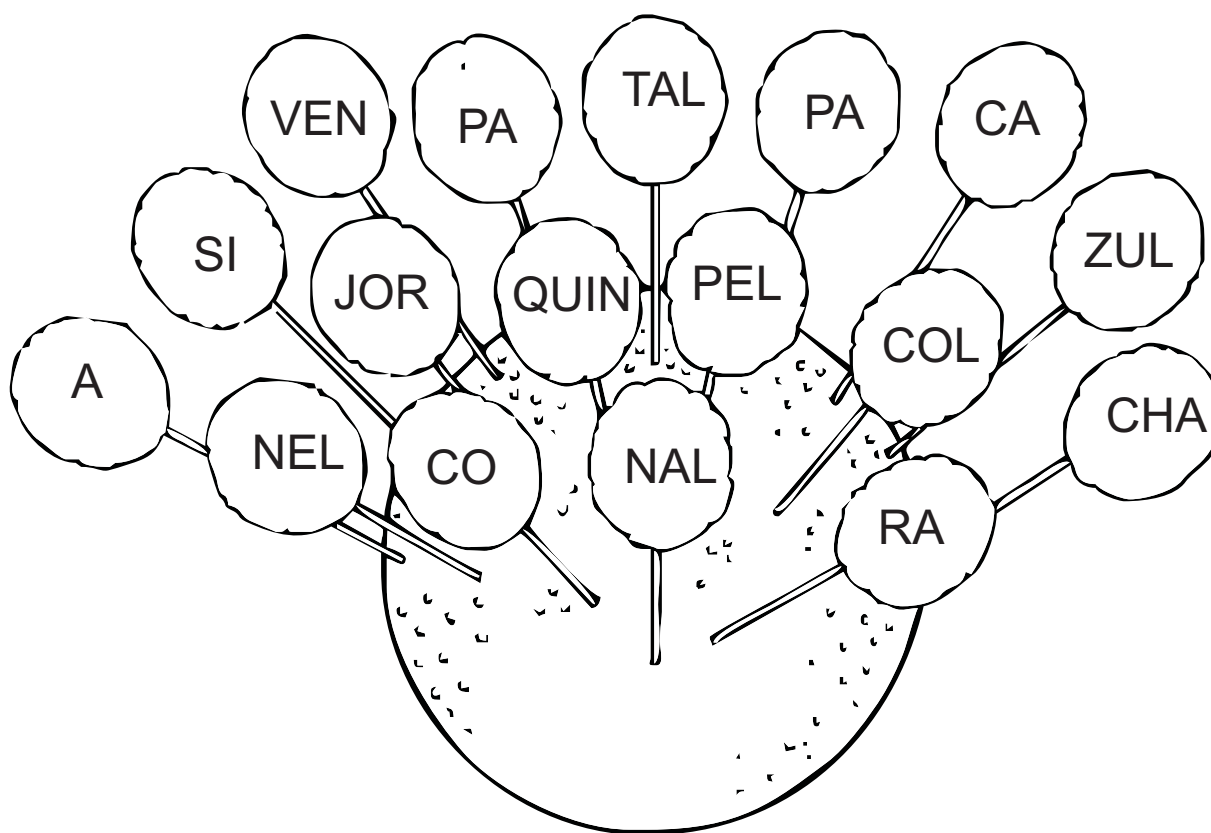



COMPLETE AS PALAVRAS COM: AL, EL, IL, OL, UL.

M \_\_\_\_\_ ANZ \_\_\_\_\_ PAST \_\_\_\_\_ CAN \_\_\_\_\_  
 FUZ \_\_\_\_\_ FAR \_\_\_\_\_ JORN \_\_\_\_\_ PAP \_\_\_\_\_  
 ANIM \_\_\_\_\_ CARRET \_\_\_\_\_ CARAC \_\_\_\_\_ BARR \_\_\_\_\_  
 AN \_\_\_\_\_ M \_\_\_\_\_ AZ \_\_\_\_\_ AVENT \_\_\_\_\_

COPIE NO CADERNO AS PALAVRAS QUE VOCÊ COMPLETOU.

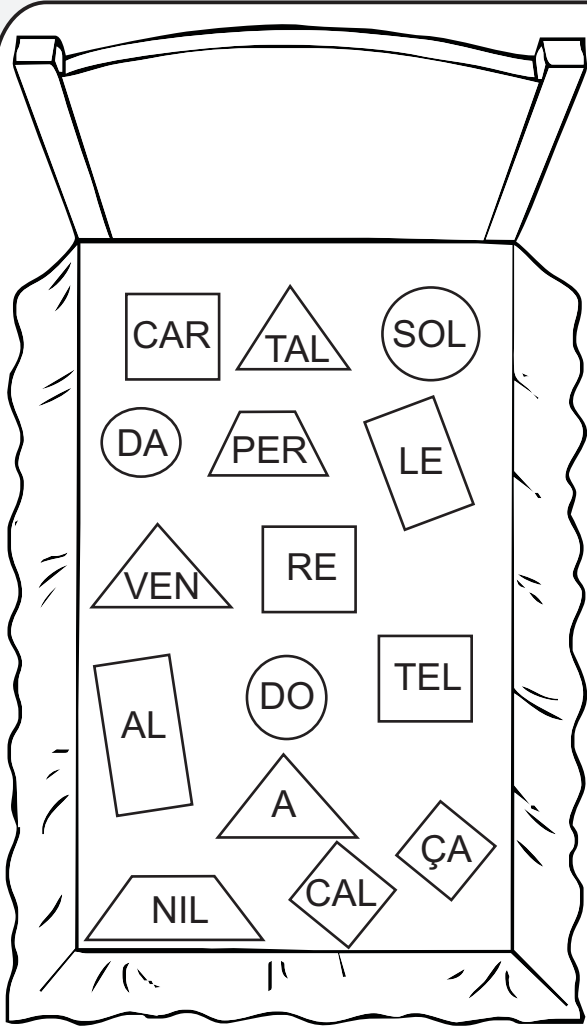
a q u b A C S Z m X N O P C G V



ESCREVA AS PALAVRAS DE ACORDO COM OS DESENHOS, E SEPRE-AS EM SÍLABAS.

○ \_\_\_\_\_ [ ] [ ] [ ]

▭ \_\_\_\_\_ [ ] [ ]





□ \_\_\_\_\_ [ ] [ ] [ ]

△ \_\_\_\_\_ [ ] [ ] [ ]

▱ \_\_\_\_\_ [ ] [ ]

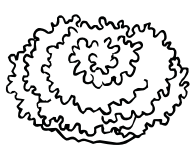
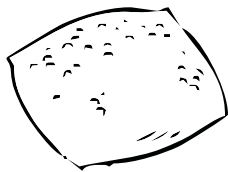
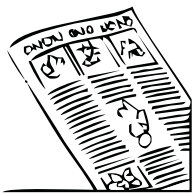
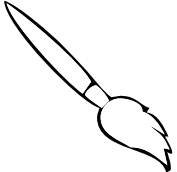
◇ \_\_\_\_\_ [ ] [ ]

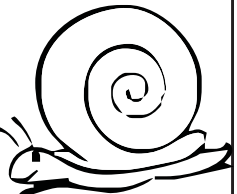
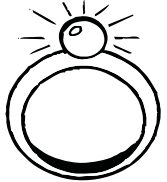
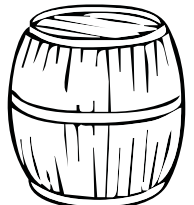
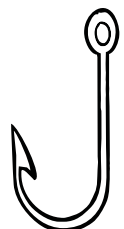
PINTE AS SÍLABAS QUE FORMAM O NOME DO DESENHO.

				
AL MA FA CE	SA LE PAS TEL	A JOR JU NAL	PIN AN CI CEL TE	PER MI RI NIL
				
CA GO RA COL A	TO NEL MEL	CA BAR TO RIL	TA AN BO ZOL	BOL COL SA

C b v h a B q A C u z m O X

FORME PALAVRAS COM AS SÍLABAS DO DESENHO.  
 PINTE CADA PALAVRA EM UMA COR.

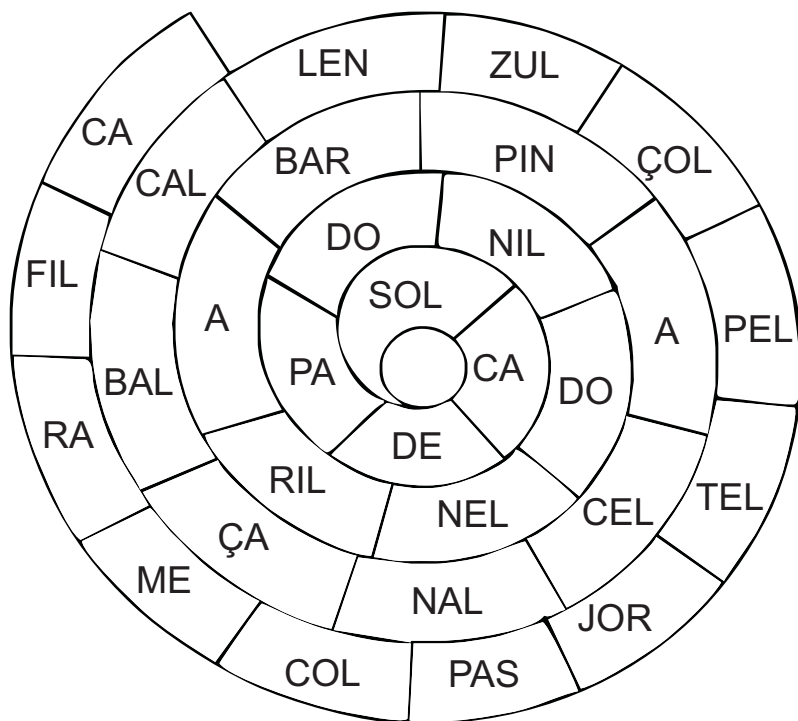

---

---

---

---

---

---

---

---

---

---

ESCOLHA QUATRO PALAVRAS QUE VOCÊ ESCREVEU,  
 COPIE E SEPRE-AS EM SÍLABAS.

--	--	--	--

COMPLETE AS FRASES COM AS  
 PALAVRAS QUE VOCÊ ESCREVEU.

EU GOSTO DE \_\_\_\_\_ DE CARNE E PALMITO.

O \_\_\_\_\_ DA MAMÃE É DE OURO.

MEU IRMÃO GOSTA DE ASSISTIR \_\_\_\_\_ DE TERROR.

O JORNALEIRO ENTREGOU O \_\_\_\_\_.

A \_\_\_\_\_ DO MEU UNIFORME É \_\_\_\_\_.

### AUTODITADO

ESCREVA PALAVRAS QUE  
CONTENHAM AL - EL - IL - OL - UL.

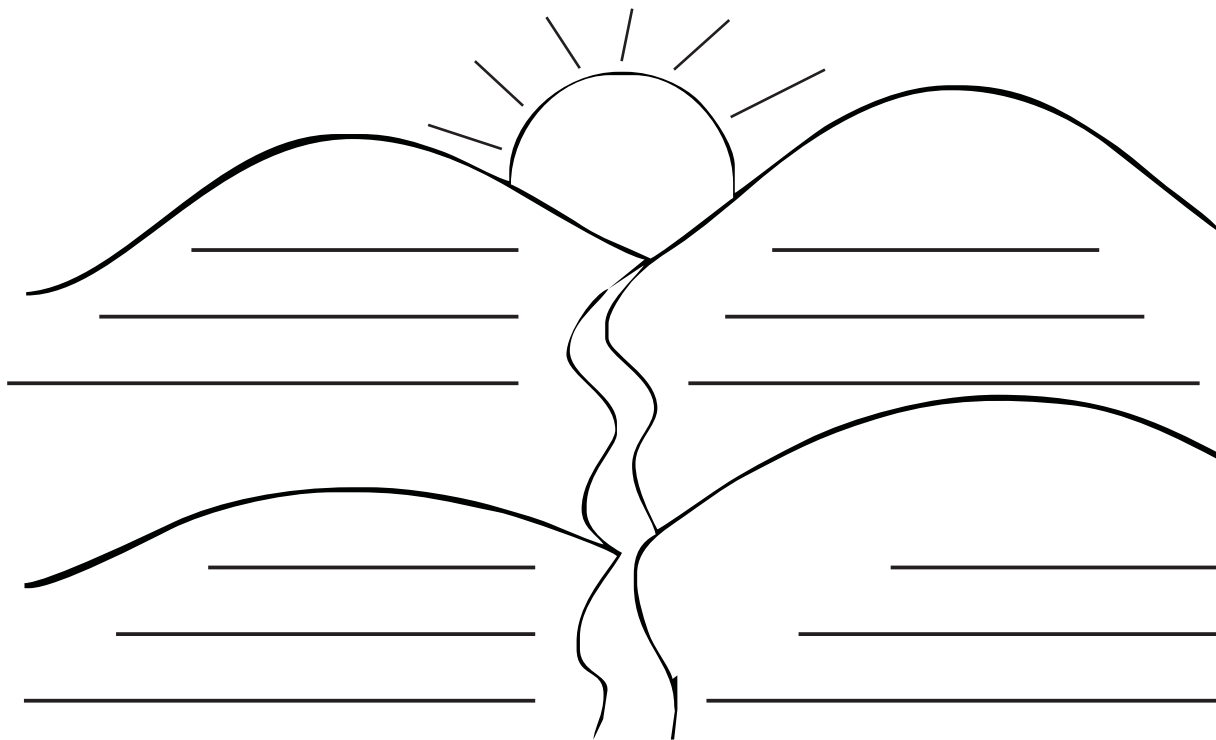

### CAÇA-PALAVRA SILÁBICO

CANIL  
JORNAL  
FAROL  
PAPEL  
ÚLTIMO  
CARACOL  
FUNIL  
COLGATE  
ANIMAL  
ALFACE  
BOLSA  
PULSEIRA  
ALMOFADA

BA	LA	FU	XA	PUL	SEI	RA	PA
DA	CA	NIL	QUA	BE	ME	XU	ZU
HA	RA	RA	AL	MO	FA	DA	YA
ZA	COL	GE	FA	NE	FE	KA	FA
A	JA	VU	CE	QUI	ZU	WA	ROL
NI	XE	COL	GA	TE	TA	LE	ZE
MAL	TE	HE	MA	VA	RE	RO	BOL
NA	PA	PEL	SE	JOR	NAL	RU	SA
DE	SA	VE	ÚL	TI	MO	SE	QUE



O CARTAZ MOSTRA PALAVRAS COM A LETRA **L**.  
CIRCULE NAS PALAVRAS AS SÍLABAS ONDE ESTÁ A LETRA **L**.



BLUSA	CLIMA	FLOR	PLACA
BÍBLIA	CLUBE		
PROBLEMA	CLARO	FLANELA	
BIBLIOTECA	DECLIVE	PLANO	
CLÍNICA	IGLU	GLOBO	ATLAS
EMBLEMA	ATLETA	ATLETISMO	
PÚBLICO	GLÚTEN	ATLÂNTICO	



VOCÊ PERCEBEU QUE, NESSAS PALAVRAS, A LETRA **L**  
ESTÁ SEMPRE ENTRE UMA VOGAL E UMA CONSOANTE.  
ELA AJUDA A FORMAR AS FAMÍLIAS DAS SÍLABAS:

bla - ble - bli - blo - blu
<i>bla - ble - bli - blo - blu</i>
cla - cle - cli - clo - clu
<i>cla - cle - cli - clo - clu</i>
fla - fle - fli - flo - flu
<i>fla - fle - fli - flo - flu</i>
gla - gle - gli - glo - glu
<i>gla - gle - gli - glo - glu</i>
pla - ple - pli - plo - plu
<i>pla - ple - pli - plo - plu</i>
tla - tle - tli - tlo - tlu
<i>tla - tle - tli - tlo - tlu</i>

COPIE AS PALAVRAS QUE ESTÃO NOS DESENHOS,  
CIRCULE AS SÍLABAS ONDE APARECEM AS  
LETRAS **BL** E **CL**. DEPOIS SEPRE-AS EM SÍLABAS.

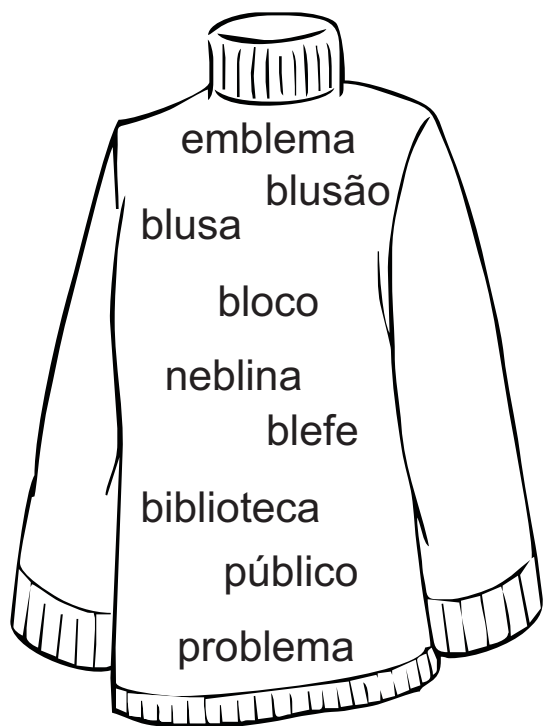

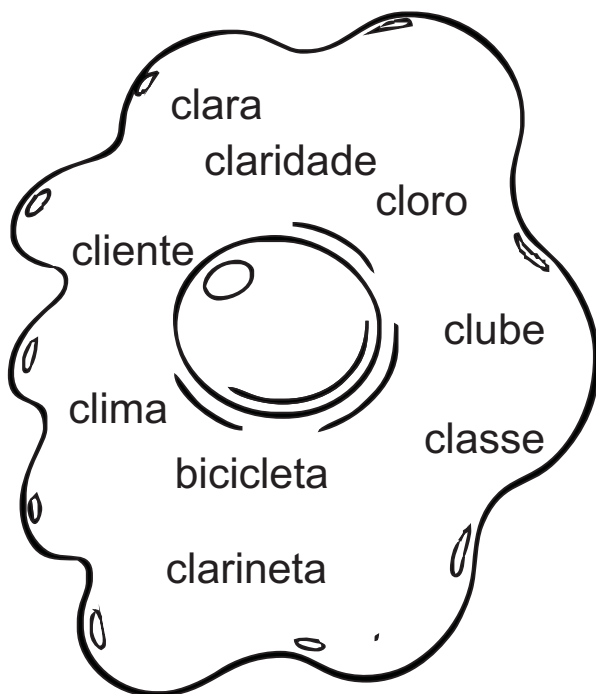
COMPLETE AS PALAVRAS QUE FALTAM NAS EXPRESSÕES, DE ACORDO COM OS DESENHOS.



\_\_\_\_\_ DE CLÁUDIO



RAMO DE \_\_\_\_\_

\_\_\_\_\_ DO CARRO

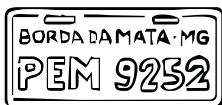

VASO DE \_\_\_\_\_



\_\_\_\_\_ DO UNIFORME



\_\_\_\_\_ DE CONCRETO

\_\_\_\_\_ DO OVO



\_\_\_\_\_ DO FLAUTISTA

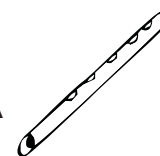

COMPLETE AS FRASES COM A PALAVRA DO QUADRO.

FLORESTA EMBLEMA FLANELA BIBLIOTECA PLANTAÇÃO

GLÁUCIA ADORA ESTUDAR NA \_\_\_\_\_ DA ESCOLA.

FUI PASSEAR NO SÍTIO DO VOVÔ E VI A \_\_\_\_\_ DE MILHO.

PAPAI LIMPOU O CARRO COM A \_\_\_\_\_.

NA \_\_\_\_\_ VIVEM MUITOS ANIMAIS.

PLÍNIO GOSTA DE DESENHAR \_\_\_\_\_ DE SEU TIME.

COMPLETE AS PALAVRAS, ESCRIVENDO AS SÍLABAS DAS FAMÍLIAS SÍLABICAS: **BL**, **CL**, **FL**.

BICI \_\_\_\_\_ TA

\_\_\_\_\_ SA

\_\_\_\_\_ RESTA

\_\_\_\_\_ MA

\_\_\_\_\_ CO

\_\_\_\_\_ UTA

\_\_\_\_\_ BE

EM \_\_\_\_\_ MA

\_\_\_\_\_ NELA

\_\_\_\_\_ RIDADE

BI \_\_\_\_\_ OTECA

\_\_\_\_\_ RICULTURA

CABO \_\_\_\_\_

\_\_\_\_\_ SÃO

\_\_\_\_\_ CHA

MOTOCI \_\_\_\_\_ TA

PRO \_\_\_\_\_ MA

RI \_\_\_\_\_

\_\_\_\_\_ RO

\_\_\_\_\_ SÃO

A \_\_\_\_\_ ÇÃO

### QUADRINHA

FUI FAZER MINHA CAMA,  
 ME ESQUECI DO COBERTOR.  
 DEU UM VENTO DA ROSEIRA  
 ENCHEU MINHA CAMA DE FLOR.



DOMÍNIO PÚBLICO.

CIRCULE E COPIE DO TEXTO A PALAVRA FLOR .  
 VAMOS DESCOBRIR NA CRUZADINHA  
 ONDE ESTÃO AS PALAVRAS COM **FL** E **GL** .

I	FLE	CHA	DA	FLAU	TA
GLU	CHA	FLO	RA	GLU	TÃO
GLO	FLO	FLA	NE	LA	GLA
BO	CO	GLI	CO	SE	CÊ

ESCREVA AS PALAVRAS QUE  
 PODEM SER FORMADAS COM  
 AS SÍLABAS DAS FLORES.

---



---



---

CIRCULE A SÍLABA DAS PALAVRAS  
 QUE APARECEM AS LETRAS **FL** E **GL** .

	FLECHA - CONFLITO - FLOR - FLÚOR FLORA - FLOCOS - FLORESTA - FLUVIAL FLORICULTURA - FLUTUAR - AFLIÇÃO
	GLEBA - GLICERINA - GLOBO - GLUTÃO GLACÊ - GLÚTEN - GLICOSE - GLAMOUR ANGLO - GLICEMIA - GLOBAL - GLEBA

ORDENE E ESCREVA AS PALAVRAS INDICADAS NAS PLACAS ABAIXO.

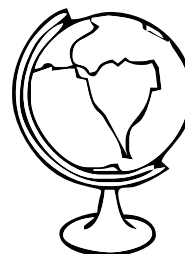

PLA-TA-NE

\_\_\_\_\_



\_\_\_\_\_

DI-MA-PLO

PLAN-NHAS-TI

\_\_\_\_\_

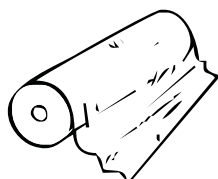

\_\_\_\_\_

CO-TI-PLÁS

LIGUE AS SÍLABAS E ESCREVA AS PALAVRAS.

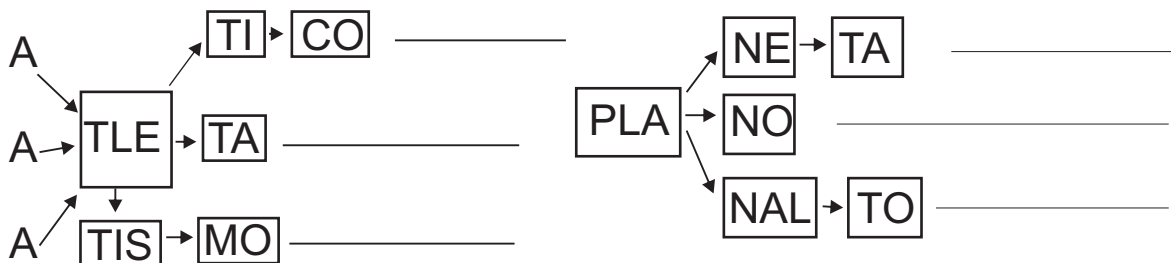

SEPRE AS PALAVRAS EM SÍLABAS E COPIE-AS.

ATLETA	ATLÉTICO	ATLÂNTICO	ATLAS

ATLETISMO	PLÁSTICO	DIPLOMA	PROBLEMA

## SAMBA LÊ LÊ

SAMBA LÊ LÊ TÁ DOENTE,  
TÁ COM A CABEÇA QUEBRADA.  
SAMBA LÊ LÊ PRECISAVA  
DE UMAS DEZOITO LAMBADAS.

SAMBA! SAMBA!  
SAMBA, Ô LÊ LÊ. } BIS  
PISA NA BARRA  
DA SAIA, Ô LÊ LÊ.



(CD CANTIGAS INFANTIS.  
CIRANDA CULTURAL, pág. 8)

CIRCULE NO TEXTO AS PALAVRAS **SAMBA** E **LAMBADAS**.

COPIE AS PALAVRAS QUE VOCÊ CIRCULOU.

VOCÊ PERCEBEU QUE A LETRA **M** ESTÁ  
APÓS A VOGAL E ANTES DA LETRA **B**?

LEIA.

om em im om um Cm Em Im Om Um

LEIA E CIRCULE AS SÍLABAS COM O **M** PÓS-VOCÁLICO.

tombo

bombom

samba

emblema

também

tambor

bombeiro

chumbo

lambari

pomba

bambu

umbigo

o

bambu

embora

lombo

JUNTE AS SÍLABAS E FORME PALAVRAS. PINTE CADA PALAVRA ENCONTRADA COM UMA COR DIFERENTE.

POM	TAM	BI	ZUM	BÉM
BOR	DO	BO	BA	BOM
BAM	TAM	RO	BO	BEI
SAM	BU	BOM	BUM	BOM
TOM	BO	JAM	BO	BO

---



---



---



---







---

FORME OUTRAS PALAVRAS, ACRESCENTANDO A LETRA **M** NO LUGAR ADEQUADO. OLHE O EXEMPLO.

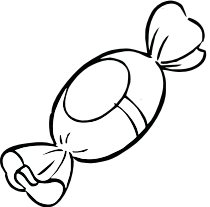
LOBO - LOMBO	BABA -	BOBEAR -
BOBA -	SOBRA -	
BOBONA -	BABO -	BOBEIRA -

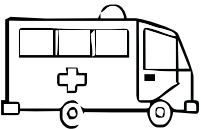
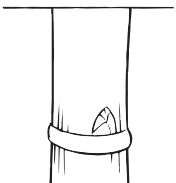
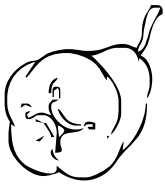
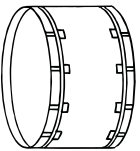
ESCREVA AS LETRAS QUE COMPLETAM AS PALAVRAS.

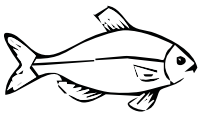
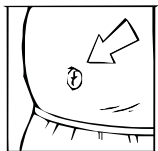
 B__BOM	 P__BA	 __BULÂNCIA	 B__BU	 J__BO
 B__BO	 CACH__BO	 B__BOLÊ	 L__BARI	 __BIGO

ORDENE AS SÍLABAS, E FORME PALAVRAS.

BA SAM _____	BU UM _____
BOM RO BEI _____	BI UM GO _____
DO ZUM BI _____	CA BO CHIM _____
BA POM _____	BO TOM _____
DA BA LAM _____	LO SÍM BO _____

CIRCULE NAS FRASES AS PALAVRAS QUE TÊM O **M** PÓS-VOCÁLICO.

AMANDA GOSTA DE OUVIR MAMBO, RUMBA E SAMBA.

O AMENDOIM ESTÁ NA PENEIRA DE BAMBU.

AQUELE JAMBEIRO ESTÁ CHEIO DE JAMBOS MADUROS.

ODAIR TEM A PROFISSÃO DE BOMBEIRO.

SERAFIM SENTOU NO LOMBO DO CAVALO.

JUNTE E ESCREVA AS PALAVRAS.

BOM	BEIRO _____	BAM	BA _____
	BOM _____		BU _____
	BACHA _____		BOLÊ _____

COMPLETE COM **M**.

BA ___ BU	BO ___ BEIRO
TO ___ BO	LO ___ BADA
SA ___ BA	SÍ ___ BOLO
JA ___ BO	A ___ BULÂNCIA
TA ___ BOR	BU ___ BO
BA ___ BOLÊ	U ___ BIGO



LEIA AS PALAVRAS E COPIE NO LUGAR ADEQUADO.

AMBULÂNCIA	ZUMBIDO	POMBA	RUMBA	
EMBALAGEM	EMBORA	BERIMBAU	TAMBOR	
UMBU	SÍMBOLO	BOMBOM	CACHIMBO	
SAMBA	POMBAL	EMBLEMA		
AM	EM	IM	OM	UM
_____	_____	_____	_____	_____
_____	_____	_____	_____	_____
_____	_____	_____	_____	_____

ESCREVA CADA DUPLA DE PALAVRAS NOS QUADRINHOS, SEPARANDO-AS EM SÍLABAS.

1- BOMBEIRO- BOMBOM

2- LAMBARI - LAMBADA

3- BAMBOLÊ - BAMBU

4- LOMBO - LOMBADA

	①	

	③	

	②	

	④

ENCONTRE AS PALAVRAS NO CAÇA-PALAVRAS, E COPIE-AS AO LADO.

BOM	BEI	RO	XA	BAM	BU
BOM	LAM	BA	DA	BO	CA
SAM	BA	UM	BU	LÊ	LHIM
BA	RI	SAM	BIS	TA	BO

\_\_\_\_\_

\_\_\_\_\_

\_\_\_\_\_

\_\_\_\_\_

\_\_\_\_\_

## O TEMPO

O TEMPO PERGUNTOU AO TEMPO  
QUANTO TEMPO O TEMPO TEM.  
O TEMPO RESPONDEU AO TEMPO  
QUE O TEMPO TEM TANTO TEMPO  
QUANTO TEMPO O TEMPO TEM?

DOMÍNIO PÚBLICO

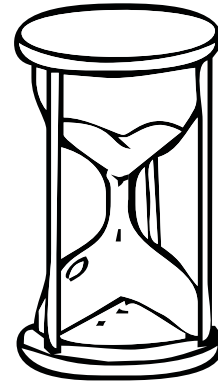

CIRCULE NO TEXTO A PALAVRA **TEMPO** E COPIE NA FICHA.

OBSERVE QUE A LETRA **M** ESTÁ  
APÓS UMA VOGAL E ANTES DA LETRA **P**.

LEIA E COPIE:

om em im om um Cm Em Im Om Um

\_\_\_\_\_

\_\_\_\_\_

LEIA E CIRCULE AS SÍLABAS COM O **M** PÓS-VOCÁLICO.

lâmpada      COMPRA      empada

tampa      rampa

BRASTEMP      CAMPANHA

componês      companheiro

COMPANHIA      campo      lampião

tempo      lamparina      tempero

ESCREVA A LETRAS QUE FALTAM E COMPLETE AS PALAVRAS.

 L__ PADA	 L__ PARINA	 L__ PIÃO	 T__ PA
 __ PADA	 __ POLA	 T__ PINHA	 C__ PAINHA

JUNTE AS SÍLABAS E FORME PALAVRAS. CADA PALAVRA ENCONTRADA, PINTE EM COR DIFERENTE.

_____	LAM	RAM	LÂM	TEM	RAL
_____	TEM	PI	PA	PA	PO
_____	PO	TEM	ÃO	POM	DA
_____	EM	PE	DA	PO	DA
_____	RO	PA	CAM	BO	TAM

ACRESCENTE A LETRA **M**,  
NAS PALAVRAS ABAIXO,  
E FORME OUTRAS PALAVRAS.

TAPA-

CAPA-

RAPA-

TAPINHA-

LIGUE E FORME PALAVRAS.

**CAM** — PO \_\_\_\_\_

          — PINHO \_\_\_\_\_

          — PONÊS \_\_\_\_\_

  

**TEM** — PO \_\_\_\_\_

          — PERO \_\_\_\_\_

          — PORAL \_\_\_\_\_

PINTE OS DESENHOS CUJAS PALAVRAS  
TÊM O **M** ANTES DE **P** E **B**. DEPOIS, ESCREVA  
ABAIXO OS NOMES DE CADA DESENHO.

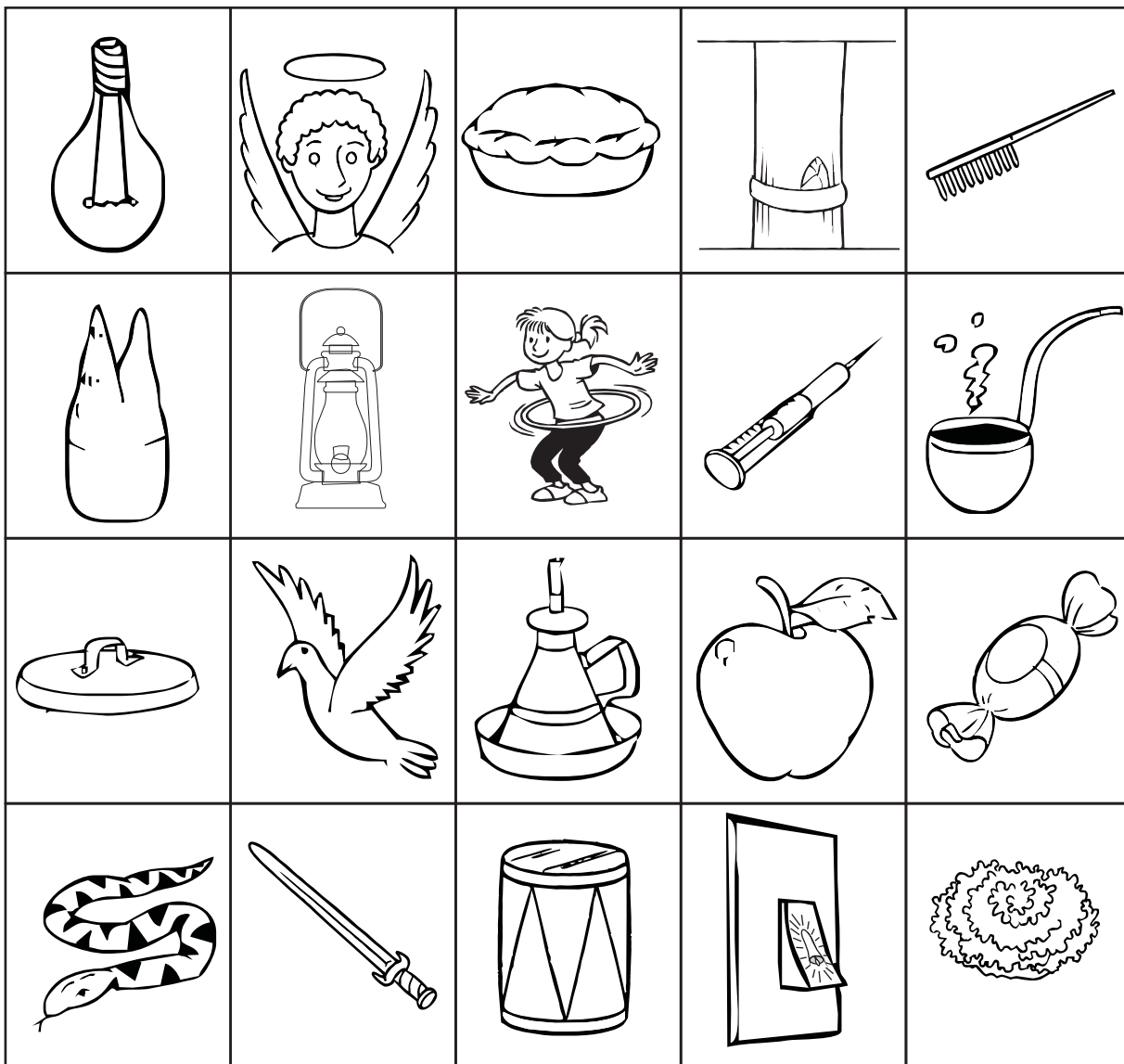

COMPLETE AS PALAVRAS COM A LETRA **M** E SEPRE-AS EM SÍLABAS.

JARDI_____	<input type="text"/>	<input type="text"/>	CAPI_____	<input type="text"/>	<input type="text"/>
BOMBO_____	<input type="text"/>	<input type="text"/>	JARDINAGE__	<input type="text"/>	<input type="text"/>
NUVE_____	<input type="text"/>	<input type="text"/>	ONTE_____	<input type="text"/>	<input type="text"/>
TAMBÉ_____	<input type="text"/>	<input type="text"/>	ALGUÉ_____	<input type="text"/>	<input type="text"/>
EMBALAGE__	<input type="text"/>	<input type="text"/>	<input type="text"/>	<input type="text"/>	<input type="text"/>
	<input type="text"/>	<input type="text"/>	AMENDOI_____	<input type="text"/>	<input type="text"/>

LEIA AS PALAVRAS E COPIE-AS NO LUGAR INDICADO.

AMBULÂNCIA	BOMBOM	<input type="text"/>	AM	<input type="text"/>	EM
EMBORA	SARAMPO	<input type="text"/>		<input type="text"/>	
TOMBO	PUDIM	<input type="text"/>		<input type="text"/>	
LIMPO	NUVEM	<input type="text"/>		<input type="text"/>	IM
UMBIGO	TUMBA	<input type="text"/>		<input type="text"/>	
TEMPO	BOM	<input type="text"/>	OM	<input type="text"/>	UM
SAMBA	SÍMBOLO	<input type="text"/>		<input type="text"/>	
UMBU	RUMBA	<input type="text"/>		<input type="text"/>	

COMPLETE COM A LETRA **M**. DEPOIS, LEIA AS PALAVRAS.

TO_____BO	SI__PÁTICO	A__POLA
BO____BEIRO	A__BULÂNCIA	SÍ__BOLO
SA__BA	LA__PARINA	NUVE__
BO__BA	TA__BÉM	E__PADA
BU__BO	E__BORA	SARA__PO

a q u b A C S z m X N O p c g V

p  
c  
c  
v  
o  
g  
s  
a  
s  
u  
D  
q  
N  
G  
ç  
h

g  
a  
s  
u  
q  
h  
z  
s  
p  
r  
D  
A  
m  
O  
V  
p  
N

### CRUZADINHA

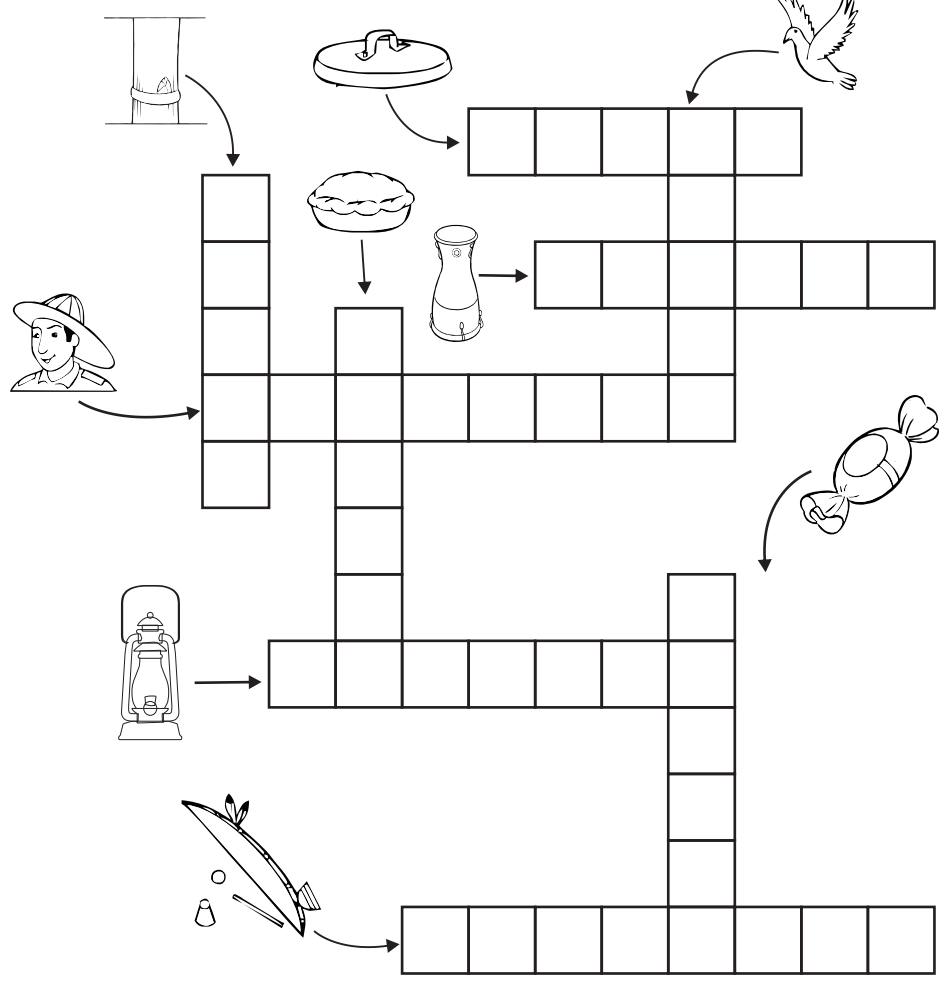

CIRCULE NAS PALAVRAS ABAIXO, AS SÍLABAS COM:

am	em	im	om	um	Am	Em	Im	Om	Um
----	----	----	----	----	----	----	----	----	----

TAMBOR	LIMPO	CAPIM	XAMPU
TAMPA	BOMBA	EMPADA	JARDIM
MARROM	CEM	BERIMBAU	BOMBEIRO
BOMBOM	CAMPO	BAMBU	UMBIGO

C b v h a B q A C u z m O X

## LARANJA DOCE

UM PÉ DE LARANJA DOCE  
QUANTO DE LARANJA DOCE DÁ?  
UM PÉ DE LARANJA DOCE  
QUANTO DE LARANJA DOCE DÁ?  
FAZ UM TUR E BALANCÊ  
RIBEIRÃO DO CEARÁ.  
FAZ UM TUR E BALANCÊ  
RIBEIRÃO DO CEARÁ.

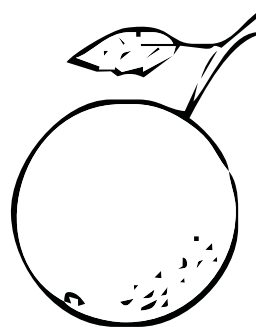

(CD AS MELHORES CANTIGAS.  
CIRANDA CULTURAL, pág. 59)

CIRCULE NO TEXTO A PALAVRA **LARANJA**.

COPIE.

an - en - in - on - un - Cn - En - In - On - Un

CIRCULE O **N** PÓS-VOCÁLICO  
NAS PALAVRAS DO QUADRO.

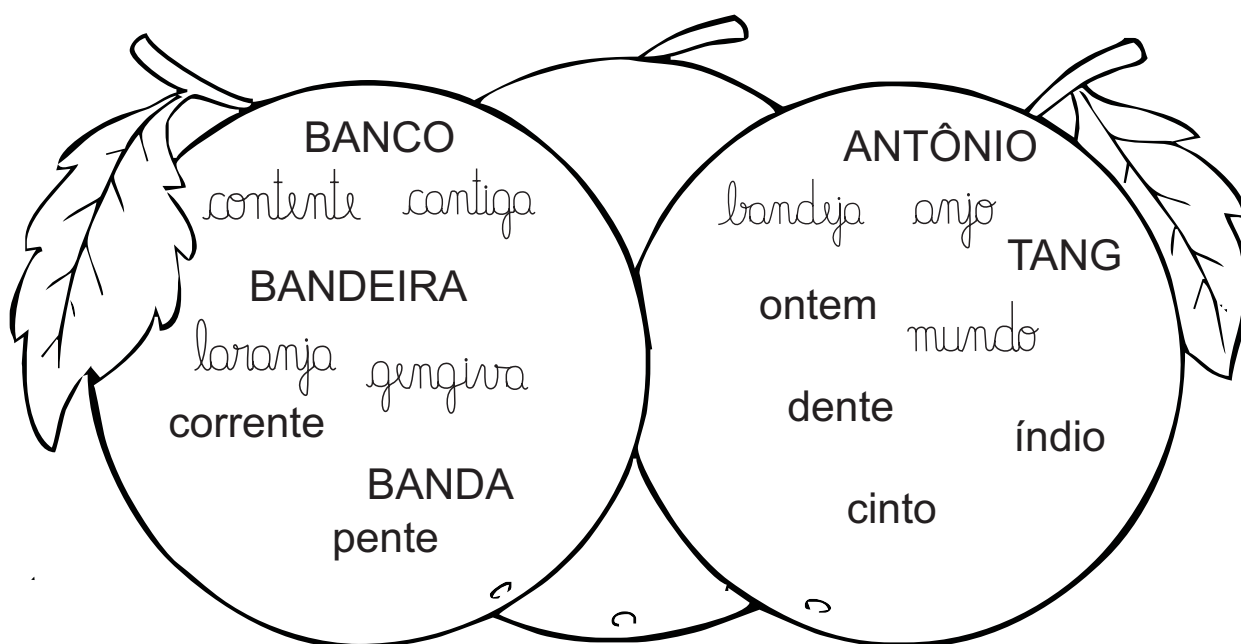

FORME PALAVRAS USANDO AS SÍLABAS  
CORRESPONDENTES AOS NÚMEROS.

1	2	3	4	5	6	7	8	9	10	11	12
AN	COR	REN	CIN	GEN	DO	TE	BAN	TA	MUN	PEN	FUN
1 - 9			5 - 7			8 - 6			4 - 9		
2 - 3 - 6			10 - 6			11 - 7			12 - 6		

SEPRE AS PALAVRAS EM SÍLABAS.

BANDA	BENGALA	GINCANA	VARANDA
MONTANHA	BALANÇA	DENTE	BANDEIRA

RECORTE AS FIGURAS ABAIXO E COLE-AS,  
DE ACORDO COM AS PERGUNTAS:  
O QUE É, O QUE É?

É USADO PARA MASTIGAR.	É USADO PARA PINTAR.	USAMOS PARA PENTEAR OS CABELOS.		
NO CAMPO É USADA PARA CAPINAR.		SAI DO OVO DA GALINHA.		
				



LEIA E COPIE AS PALAVRAS, NO LUGAR INDICADO.

AN

EN

IN

ON

UN

- |         |         |
|---------|---------|
| ANDAR   | ONÇA    |
| LENTE   | AFUNDA  |
| ONDE    | ANTA    |
| ÍNDIO   | UNTAR   |
| ENSINO  | ENSAIO  |
| ENXADA  | ANJO    |
| INVERNO | ONDA    |
| FUNDO   | INTEIRO |
| ANTIGO  | ONTEM   |
| JANTAR  | PINGO   |

ESCREVA OS NOMES DOS DESENHOS.

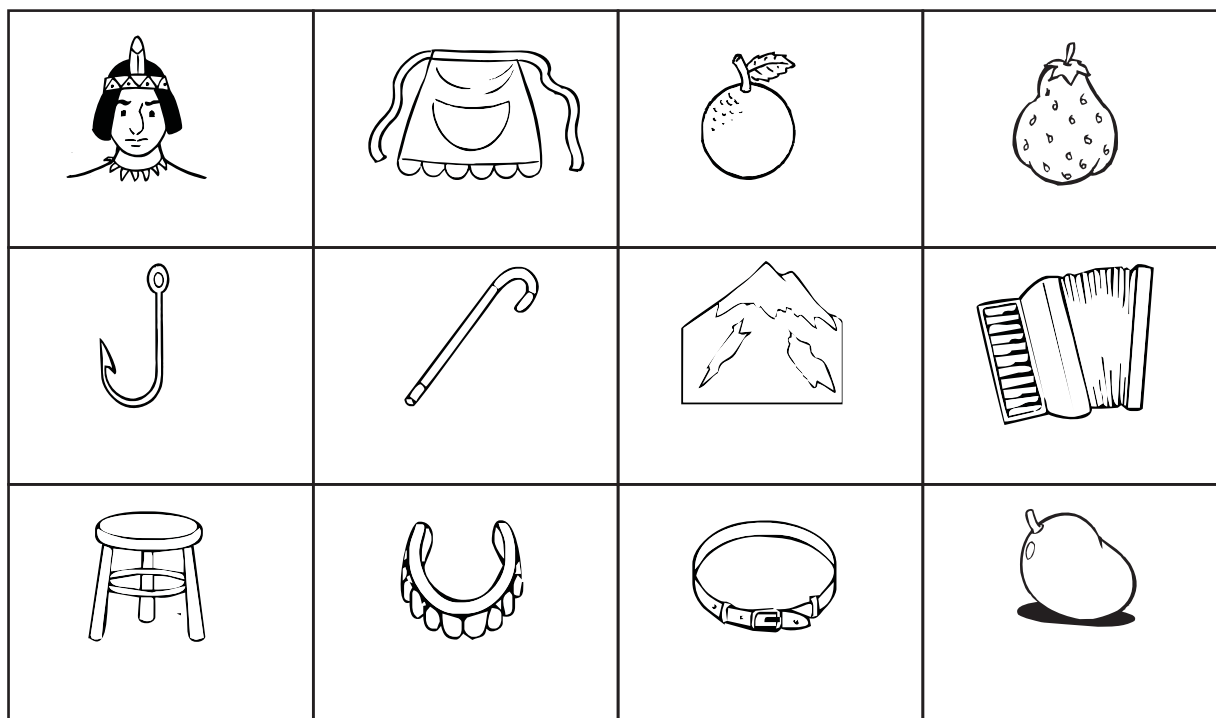

FORME PALAVRAS COM AS SÍLABAS ABAIXO.

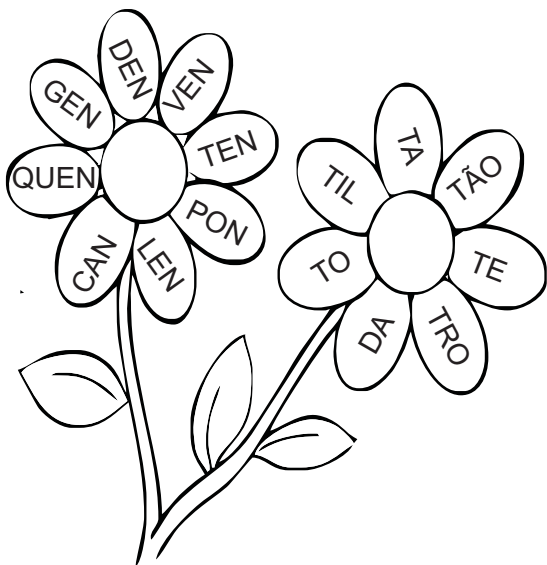

VEN		
TEN		
PON		
QUEN		
CAN		
GEN		
DEN		

LEIA AS PALAVRAS E DEPOIS ESCREVA-AS NO GRUPO CORRESPONDENTE.

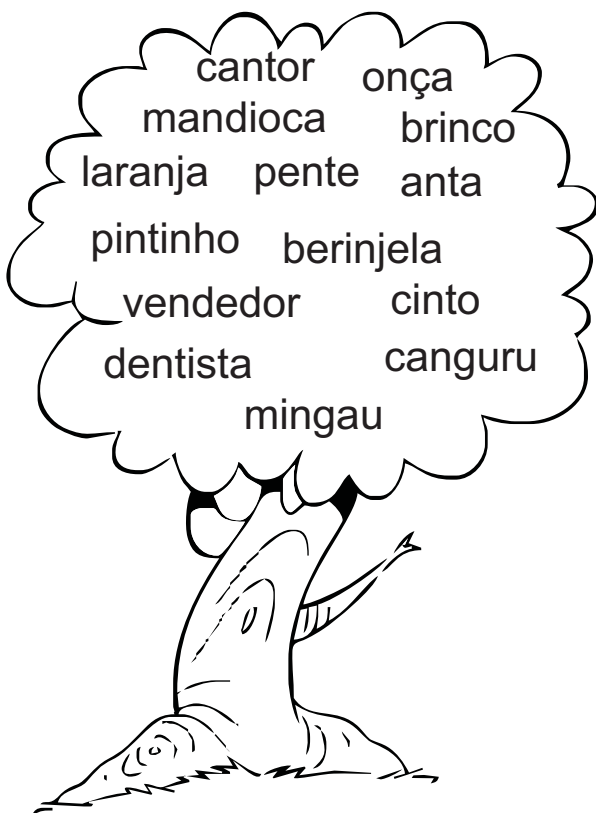

PROFISSÕES
ANIMAIS
ALIMENTO
OBJETOS

JUNTE AS FORMAS IGUAIS E FORME PALAVRAS.

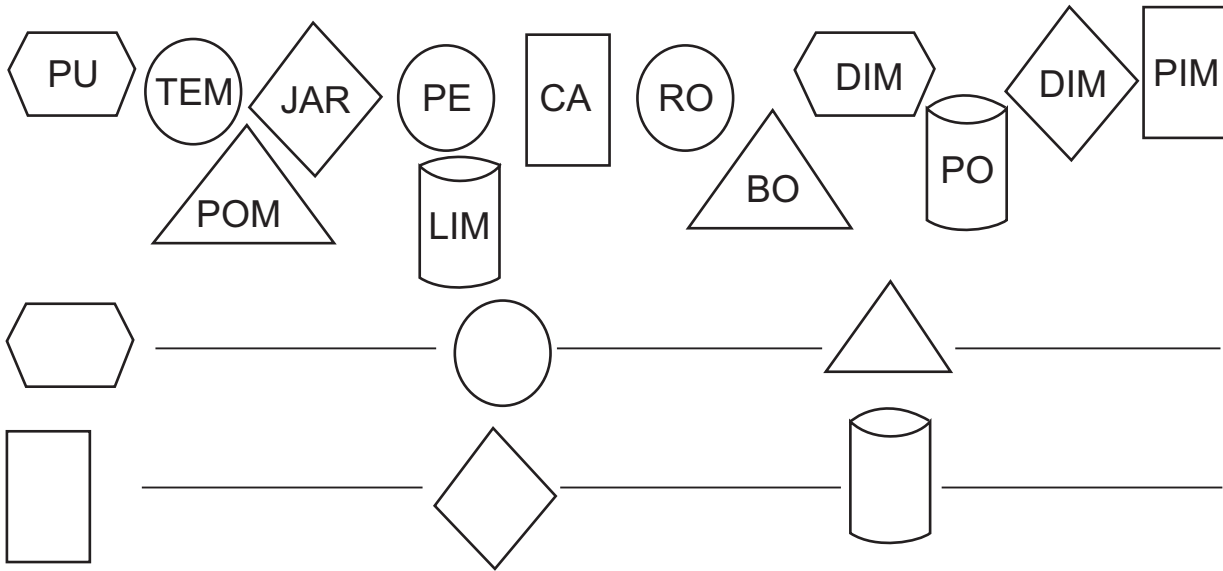

DESCUBRA OUTRAS PALAVRAS, ACRESCENTANDO A LETRA **N**.

POTE - PONTE	PESA -
VETO -	PITA -
MATA -	DADO -
SODA -	BODE -
SETE -	MUDO -
SETA -	TETA -
ATA -	NUCA -

VEJA OS DESENHOS E COMPLETE COM A PALAVRA **MANGA**.



A \_\_\_\_\_ AMADURECEU E CAIU DA MANGUEIRA.



JOÃO DESCOSTUROU A \_\_\_\_\_ DO PALETÓ.



ONTEM DEU UMA \_\_\_\_\_ D'ÁGUA.

SIGA O MODELO. DEPOIS, COPIE E SEPRE AS SÍLABAS DAS PALAVRAS.

**BOMBEIRO = BOM - BEI - RO**

M	BOMBEIRO	<input type="text"/>	<input type="text"/>	<input type="text"/>	<input type="text"/>
	EMPADA	<input type="text"/>	<input type="text"/>	<input type="text"/>	<input type="text"/>
	SANTA	<input type="text"/>	<input type="text"/>	<input type="text"/>	<input type="text"/>
N	ENXADA	<input type="text"/>	<input type="text"/>	<input type="text"/>	<input type="text"/>
	JARDIM	<input type="text"/>	<input type="text"/>	<input type="text"/>	<input type="text"/>
	LÂMPADA	<input type="text"/>	<input type="text"/>	<input type="text"/>	<input type="text"/>
	CANTO	<input type="text"/>	<input type="text"/>	<input type="text"/>	<input type="text"/>
	CAMPO	<input type="text"/>	<input type="text"/>	<input type="text"/>	<input type="text"/>

SEPRE AS SÍLABAS E COPIE AS PALAVRAS.

CANTA    \_\_\_\_\_    \_\_\_\_\_

ENLATADO    \_\_\_\_\_    \_\_\_\_\_

CANSADO    \_\_\_\_\_    \_\_\_\_\_

LINDA    \_\_\_\_\_    \_\_\_\_\_

BANDA    \_\_\_\_\_    \_\_\_\_\_

PANDEIRO    \_\_\_\_\_    \_\_\_\_\_

COMPLETE OS NOMES DOS DESENHOS NOS DIAGRAMAS.

COMPLETE COM **M** OU **N**.

TA\_\_PA

BA\_\_BU

MA\_\_GA

TA\_\_BOR

GE\_\_TE

HOME\_\_

SE\_\_TADO

CO\_\_FETE

ESCO\_\_DIDO

BO\_\_BEIRO

DE\_\_TADURA

BOTEQUI\_\_

CO\_\_PANHEIRO

VE\_\_DO

CA\_\_TO

NUVE\_\_

TA\_\_BÉ\_\_

O\_\_TE\_\_

ESCOLHA TRÊS PALAVRAS QUE VOCÊ COMPLETOU,  
ESCREVA NAS FICHAS E FORME FRASES.

\_\_\_\_\_

\_\_\_\_\_

\_\_\_\_\_

COMPLETE AS EXPRESSÕES COM AS PALAVRAS DO QUADRO.

JAMBO - ZUMBIDO - BAMBU - MANGA - TAMP  
SÍMBOLO - EMPADA - LÂMPADA - PUDIM - SAMBA

PENEIRA DE \_\_\_\_\_

\_\_\_\_\_ MADURO

\_\_\_\_\_ DA PANELA

\_\_\_\_\_ DE FRANGO

\_\_\_\_\_ DE LEITE

\_\_\_\_\_ NO OUVIDO

\_\_\_\_\_ ACESA

\_\_\_\_\_ MADURA

\_\_\_\_\_ NACIONAL

\_\_\_\_\_ NO PÉ

FORME PALAVRAS



\_\_\_\_\_

\_\_\_\_\_

\_\_\_\_\_

\_\_\_\_\_

DESCUBRA O SEGREDO E CONTINUE.

PON	POM	TE	BA
CAN	CAM	TO	PO
SAN	SOM	TO	BRA
TAN	TAM	TO	PA
TEN	DA	TEM	PO

N	

M	

COMPLETE AS FRASES COM AS PALAVRAS DAS FICHAS.

FOGO - RESPEITO - CARRO - BOMBEIRO - COMPANHEIRO

UMBERTO É UM \_\_\_\_\_.

NÓS VIMOS O \_\_\_\_\_ DOS BOMBEIROS.

OS BOMBEIROS COMBATEM O \_\_\_\_\_.

ELES SÃO NOSSOS \_\_\_\_\_.

DEVEMOS MUITO \_\_\_\_\_ AOS BOMBEIROS.

COPIE E CIRCULE NAS PALAVRAS ABAIXO AS SÍLABAS COM:

*an - en - in - on - un - Cn - En - In - On - Un*

--

anjo	cinto	ponte	pente
bandeira	bandeja	laranja	cinta
pintura	pontudo	contente	valente
tinta	enxada	mentira	pingo

COMPLETE O QUADRO. SIGA O MODELO.

SÍLABA	PALAVRA	FRASES
AM	CAMPO	MAMÃE GOSTA DE FLORES DO CAMPO.
EM		
IM		
OM		
UM		

AN	LARANJA	EU GOSTO DE TOMAR SUCO DE LARANJA.
EN		
IN		
ON		
UN		

### DE OLHOS VERMELHOS

DE OLHOS VERMELHOS, DE PÊLO BRANQUINHO,  
DE PULO BEM LEVE, EU SOU COELHINHO!  
SOU MUITO ASSUSTADO, PORÉM, SOU GULOSO  
POR UMA CENOURA JÁ FICO MANHOSO

EU PULO PRÁ FRENTE, EU PULO PRÁ TRÁS  
DOU MIL CAMBALHOTAS SOU FORTE DEMAIS!  
COMI UMA CENOURA, COM CASCA E TUDO  
TÃO GRANDE ELA ERA, FIQUEI BARRIGUDO.



(CD AS MAIS BELAS CANTIGAS DE RODA.  
CIRANDA CULTURAL, pág. 83)

LEIA AS PALAVRAS ABAIXO. PROCURE ESSAS  
PALAVRAS NO TEXTO ACIMA E CIRCULE-AS.

OLHOS - VERMELHOS - ASSUSTADO - TRÁS  
CAMBALHOTAS - DEMAIS - CASCA

CIRCULE A LETRA **S**, QUE ESTÁ APÓS AS  
VOGAIS. DIZEMOS QUE O **S** É PÓS-VOCÁLICO.

COPIE.

as - es - is - os - us

As - Es - Is - Os - Us



DESCUBRA O SEGREDO E ESCREVA OUTRAS PALAVRAS

PASTA

\_\_\_\_\_

FESTA

\_\_\_\_\_

RISCO

\_\_\_\_\_

MOSCA

\_\_\_\_\_

SUSTO

\_\_\_\_\_

LIGUE AS SÍLABAS E ESCREVA AS PALAVRAS.

MOS \_\_\_\_\_  
 ROS — CA \_\_\_\_\_  
 DIS \_\_\_\_\_

FES \_\_\_\_\_  
 CES — TA \_\_\_\_\_  
 POS \_\_\_\_\_

AS — MA \_\_\_\_\_  
 — NO \_\_\_\_\_  
 — SIM \_\_\_\_\_

IS — TO \_\_\_\_\_  
 — SO \_\_\_\_\_  
 — CA \_\_\_\_\_

ESCREVA AS PALAVRAS E SEPRE-AS EM SÍLABAS.

ESTOJO	SUSTO	ESCURO	MÁSCARA
_____	_____	_____	_____
□ □ □	□ □	□ □ □	□ □ □

CASTELINHO	BISCOITO	ESCOVA
_____	_____	_____
□ □ □ □	□ □ □	□ □ □

PINTE AS SÍLABAS QUE CORRESPONDEM AOS DESENHOS.



Ô	TO
NI	BUS

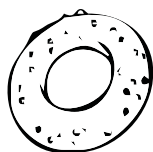

BIS	TA
COI	TO



MÁS	PA
CA	RA



AS	ES
CO	VA

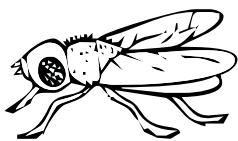

MOS	QUI	BO	TO
-----	-----	----	----



ES	TI	QUI	LO
----	----	-----	----

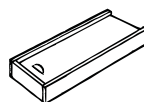

ES	DO	TO	JO
----	----	----	----



ES	CA	TA	DA
----	----	----	----

QUAL O NÚMERO DE SÍLABAS DE CADA PALAVRA? ESCREVA NAS ESPIGAS.

LAGOSTA



FÓSFORO



ESPADINHA



CESTA



ESCOLINHA



RISCO



ESPELHINHO



FESTINHA



BISCOITO



PASTA



CONTINUE.



A ESCADA



AS \_\_\_\_\_

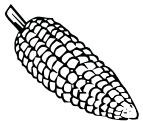

A \_\_\_\_\_

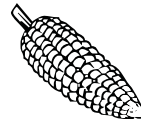
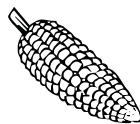

AS \_\_\_\_\_



O \_\_\_\_\_

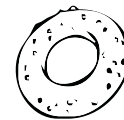
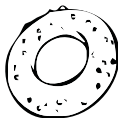

OS \_\_\_\_\_



A \_\_\_\_\_



AS \_\_\_\_\_



O \_\_\_\_\_



OS \_\_\_\_\_

LIGUE OS DESENHOS, DE ACORDO COM AS PALAVRAS.

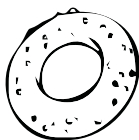
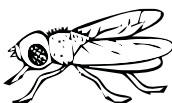
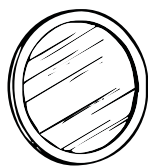

ESCOLA

OLHOS

ESPELHO

LÁPIS

POSTE

ISQUEIRO

ESPIGA

MOSCA

ESCADA

ESCOVA

CESTA

BISCOITO

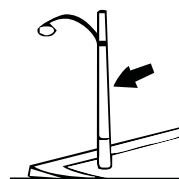

PREENCHA O QUADRO ESCREVENDO O QUE SE PEDE.

SÍLABA	OBJETO	NOME DE PESSOA	NOME ANIMAL	PARTE DO NOSSO CORPO
ES				
OS				

DESCUBRA O SEGREDO E ESCREVA OUTRAS PALAVRAS

ASMA- \_\_\_\_\_  
 \_\_\_\_\_

ISCA \_\_\_\_\_  
 \_\_\_\_\_

SUSTO \_\_\_\_\_  
 \_\_\_\_\_

COMPLETE AS PALAVRAS COM: **AS**, **ES**, **IS**, **OS**, **US**.

ÔNIB\_\_

R\_\_CA

F\_\_TA

R\_\_CO

M\_\_QUITO

\_\_TÁ

\_\_NO

P\_\_TA

S\_\_PIRO

\_\_STO

\_\_QUILO

C\_\_TA

M\_\_CA

S\_\_TO

B\_\_TA

P\_\_CA

R\_\_CO

B\_\_TO

a q u b A C S z m X N O p c G V

JUNTE AS SÍLABAS E FORME PALAVRAS.

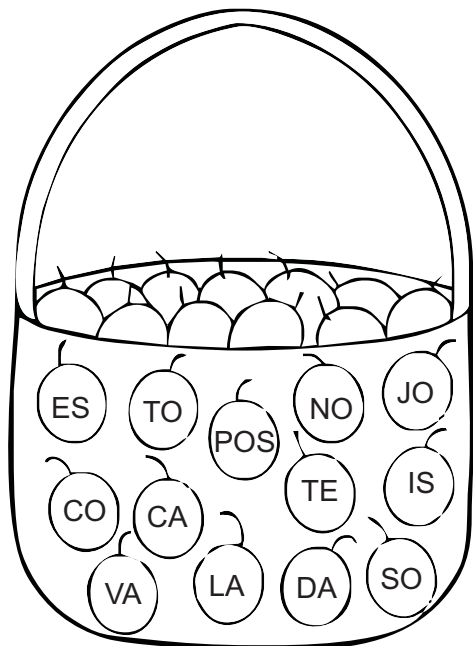

\_\_\_\_\_

\_\_\_\_\_

\_\_\_\_\_

\_\_\_\_\_

\_\_\_\_\_

LEIA AS PALAVRAS E COPIE-AS NO LUGAR INDICADO.

ASNO   ÔNIBUS   RESTO   ESTOJO   FUSCA

BUSTO   AGOSTO   DISCO   SUSTO

PASTA   LÁPIS

MÁSCARA   MOSCA   ROSTO   ESMOLA

POSTE   VESTIDO   CASTELO

AS   ES   IS   OS   US

_____	_____	_____	_____	_____
_____	_____	_____	_____	_____
_____	_____	_____	_____	_____
_____	_____	_____	_____	_____

C b v H a B q A C u z m O X

DESCUBRA O SEGREDO E CONTINUE O CAMINHO.  
ESCREVENDO AS PALAVRAS QUE FALTAM.

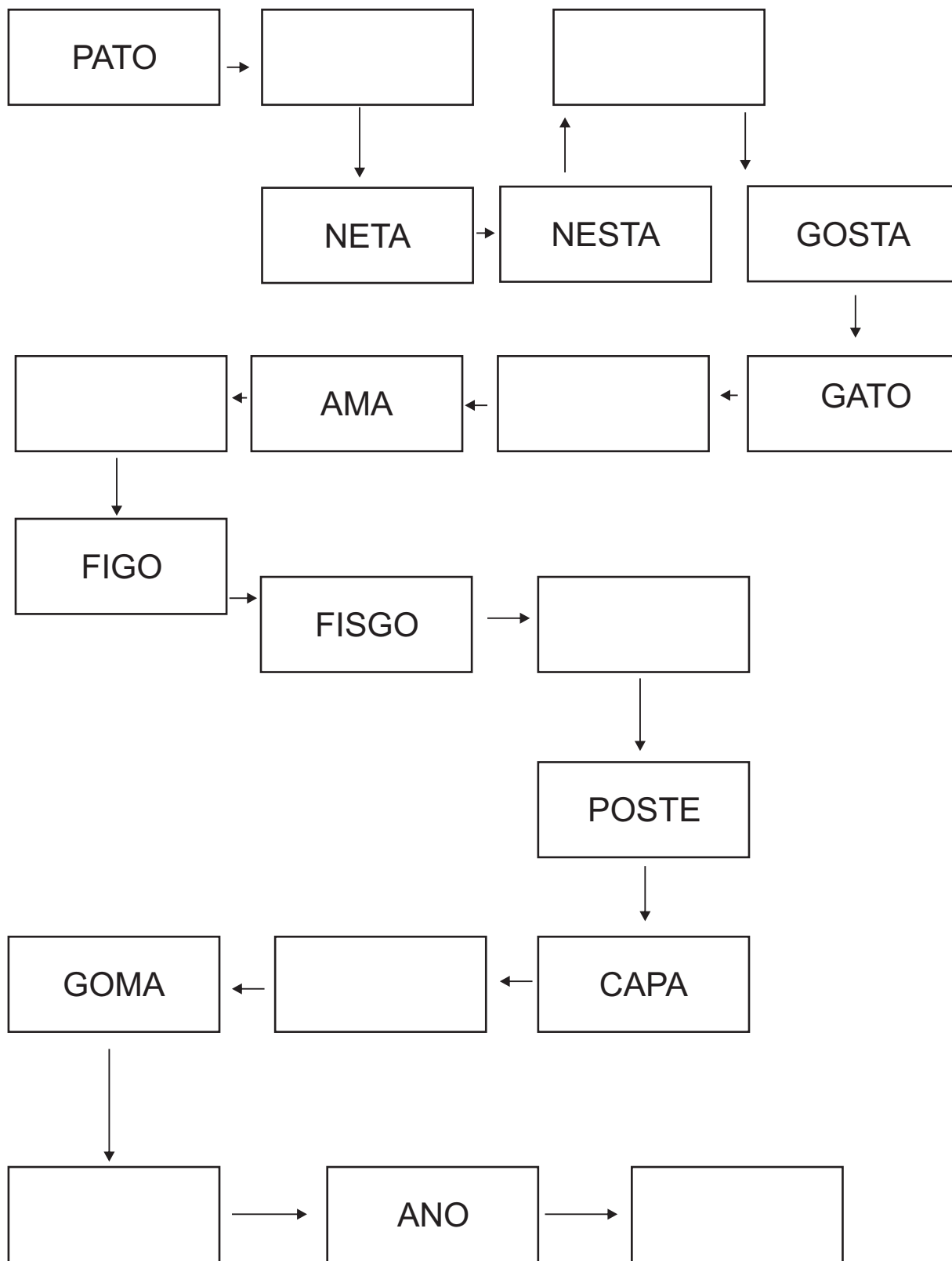

## REPIU, PIU, PIU

REPIU, PIU, PIU  
CANTA O PASSARINHO  
REPIU, PIU, PIU  
MAL O SOL SURGIU.  
REPIU, PIU, PIU  
REPIU, PIU, PIU  
REPIU, PIU, PIU  
PIU, PIU, PIU, PIU

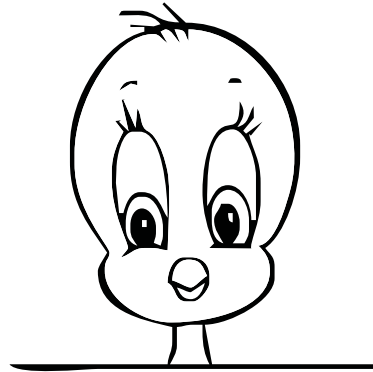

(CD AS MAIS BELAS CANTIGAS DE RODA.  
CIRANDA CULTURAL, pág.88)

CIRCULE NO TEXTO A PALAVRA **PASSARINHO**.

COPIE.

ssa - sse - ssi - sso - ssu

Blank box for copying the words.

LEIA AS PALAVRAS. OBSERVE  
O QUE ELAS TÊM DE IGUAL.



OBS: AS LETRAS **S** JUNTAS - **SS** - APARECEM  
ENTRE VOGAIS E TÊM O SOM DE **S** MAIS FORTE.

LIGUE AS SÍLABAS E ESCREVA AS PALAVRAS.

TOS      SO \_\_\_\_\_      AS      SE \_\_\_\_\_

MIS      SE \_\_\_\_\_      IS      SA \_\_\_\_\_

OS      SE \_\_\_\_\_      DIS      SA \_\_\_\_\_

DIS      SA \_\_\_\_\_      MAS      SO \_\_\_\_\_

JUNTE AS SÍLABAS E ESCREVA AS PALAVRAS.

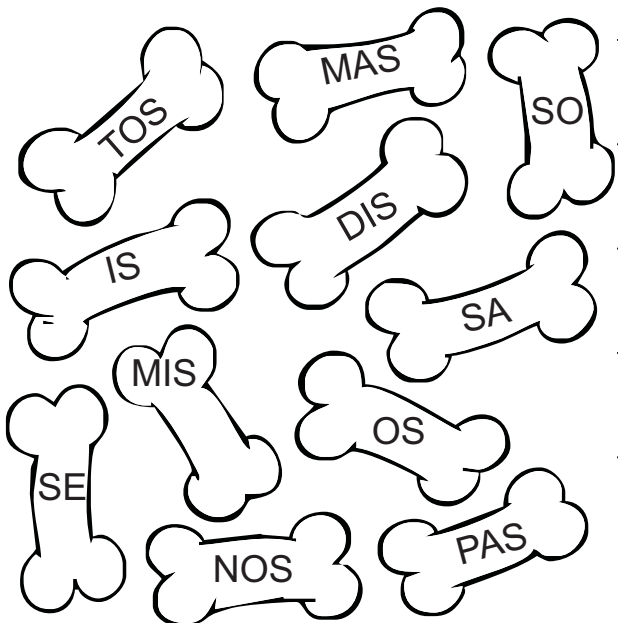

A collection of ten bone-shaped pieces, each containing a syllable: TOS, MAS, SO, IS, DIS, SA, MIS, OS, SE, NOS, PAS. To the right of these bones are five horizontal lines for writing the words formed by joining the syllables.

DESCUBRA O SEGREDO E ESCREVA OUTRAS PALAVRAS

OSSO  
\_\_\_\_\_  
\_\_\_\_\_  
\_\_\_\_\_

OSSUDO  
\_\_\_\_\_  
\_\_\_\_\_  
\_\_\_\_\_

DISSE  
\_\_\_\_\_  
\_\_\_\_\_  
\_\_\_\_\_

MÍSSIL  
\_\_\_\_\_  
\_\_\_\_\_  
\_\_\_\_\_

MASSA  
\_\_\_\_\_  
\_\_\_\_\_  
\_\_\_\_\_



JUNTE AS SÍLABAS E ESCREVA AS PALAVRAS.

VAS SOU RA PAS SA DO PAS SA RE LA MAS SA

AS SO A LHO TOS SE PÊS SE GO GI RAS SOL

DIS SE PAS SA GEM AS SE A DO A VES SO

VAMOS COMPLETAR AS PALAVRAS COM **S** OU **SS**.

\_\_\_ APATO

DEZE \_\_\_ EIS

\_\_\_ APO

\_\_\_ ETE

\_\_\_ OPA

PROFE \_\_\_ ORA

\_\_\_ ERENO

A \_\_\_ OBIO

MÍ \_\_\_ IL

\_\_\_ ELO

\_\_\_ EMÁFARO

PÁ \_\_\_ ARO

O \_\_\_ O

A \_\_\_ USTADO

SO \_\_\_ EGO

\_\_\_ O \_\_\_ EGADO

\_\_\_ UCO

\_\_\_ OL

A \_\_\_ OALHO

\_\_\_ EMANA

\_\_\_ EIS

RESPONDA AS PERGUNTAS ABAIXO,  
ESCREVENDO AS RESPOSTAS.

QUAL É O OBJETO USADO PARA VARRER A CASA?

QUAL É A FLOR QUE TEM A PALAVRA SOL NO NOME?

QUAL FRUTA É DO PESSEGUEIRO.

O QUE O CÃO ADORA ROER?

QUAL NÚMERO VEM DEPOIS DO QUINZE?

QUEM ENSINA AS CRIANÇAS A LER E ESCREVER?

SEPARE AS SÍLABAS E DEPOIS ESCREVAAS PALAVRAS.

PASSA	<input type="text"/>	<input type="text"/>	_____	PÊSSEGO	<input type="text"/>	<input type="text"/>	<input type="text"/>	_____
GESSO	<input type="text"/>	<input type="text"/>	_____	BÚSSOLA	<input type="text"/>	<input type="text"/>	<input type="text"/>	_____
MISSA	<input type="text"/>	<input type="text"/>	_____	ASSADO	<input type="text"/>	<input type="text"/>	<input type="text"/>	_____
PESSOA	<input type="text"/>	<input type="text"/>	<input type="text"/>	ASSADEIRA	<input type="text"/>	<input type="text"/>	<input type="text"/>	<input type="text"/>
OSSUDO	<input type="text"/>	<input type="text"/>	<input type="text"/>	PASSE	<input type="text"/>	<input type="text"/>		_____
INTERESSE	<input type="text"/>	<input type="text"/>	<input type="text"/>	<input type="text"/>	SOSSEGADO	<input type="text"/>	<input type="text"/>	<input type="text"/>

PINTE AS LETRAS **SS** NAS PALAVRAS ABAIXO DE ACORDO COM A INDICAÇÃO.

PÁSSARO	AMASSA	PASSA	ASSADO
	MISSA	PASSAGEM	
CASSETE	INTERESSE	TOSSE	PASSEIO
	PÊSSEGO	ASSEADO	
MISSIONÁRIO	ASSINATURA	MOCASSIM	ASSIM
	ASSISTIR	PASSINHO	
VASSOURA	PESSOA	NOSSO	ASSOBIO
	AVESSO	BÚSSOLA	
ASSUMIR	ASSUNTO	OSSUDO	ASSUMIU
	POSSUIR	ASSUSTADO	

LEIA AS PALAVRAS E COPIE-AS NOS QUADROS INDICADOS

SSA

---



---



---



---



---

MASSA	TOSSE
CASSINO	RUSSO
PESSOA	ASSADURA
ASSEIO	ASSINAR
MISSA	PASSEIO
OSSO	ASSOBIO
DISSE	ASSUNTO
PÁSSARO	ASSUSTADO
GESSO	PÊSSEGO
SUSSURRO	ASSADO

SSE

---



---



---



---



---

SSI

---



---



---



---



---

SSO

---



---



---



---



---

SSU

---



---



---

PINTE OS QUADROS EM QUE A LETRA **S**,  
NAS PALAVRAS, TEM O MESMO SOM.

PÊSSEGO POSE	SOCO PESSOA	ASSADO MESA	SALA ASSADURA
SACOLA MISSA	SAIA RISADA	PASSEATA SELO	SAPATO ASA
CASEIRO SEMANA	SONHO ASSOBIO	AVISO SOCO	SUCO ASSUSTADO
PASSEIO SECO	VISITA ASSINATURA	ASSANHADO SALAME	SINO ASILO

ORDENE AS PALAVRAS E ESCREVA AS FRASES.

DE ASSADO. PEIXE CÁSSIO GOSTA

SUCO PÊSSEGO. SÔNIA DE FEZ

TOMOU XAROPE. MELISSA O

O VANESSA OSSO DÁ AO CÃO.

ENCONTRE AS PALAVRAS NO DIAGRAMA.

Z	P	A	S	S	E	I	O	X
X	Z	S	A	W	Y	U	K	Z
W	A	S	S	O	A	L	H	O
K	S	A	S	M	P	N	P	Q
A	S	S	A	D	E	I	R	A
L	A	R	D	O	S	S	O	T
M	N	T	O	S	S	E	U	V
N	H	Z	K	Q	O	W	K	B
O	A	E	U	B	A	C	A	D
P	D	R	T	U	V	X	Z	K
Q	O	S	G	E	S	S	O	W

PASSEIO  
GESSO  
ASSADEIRA  
TOSSE  
OSSO  
ASSOALHO  
ASSA  
ASSANHADO  
ASSADO  
PESSOA

RECORTE AS FICHAS DAS FIGURAS  
E COLE NO LUGAR INDICADO.

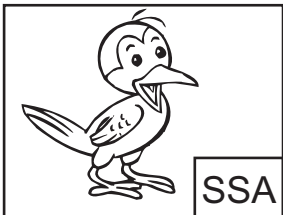

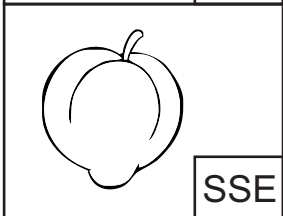





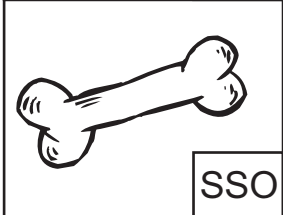



PESSOAS	DEZESSETE	ASSUSTADO	PASSAS
PASSARELA	OSSUDO	VASSOURA	SUSSURRO
ASSINATURA	ASSADO	ASSISTIR	ASSOALHO
PASSEIO	ASSIM	MASSA	ASSINAR
ASSUNTO	ASSOBIO	DEZESSEIS	TOSSE

LEIA AS PALAVRAS E ESCREVA-AS NAS FRASES.

ASSOBIOU MISSA PESSEQUEIRO  
TOSSIU DEZESSEIS

EU VI UM SABIÁ NO \_\_\_\_\_.

VANESSA \_\_\_\_\_ MUITO A NOITE.

CÁSSIO \_\_\_\_\_ E O CÃO LATIU.

MELISSA VAI TODO DOMINGO À \_\_\_\_\_.

MESSIAS JÁ ESTÁ COM \_\_\_\_\_ ANOS.

CONTINUE ESCREVENDO AS PALAVRAS  
NOS GRUPOS ADEQUADOS.

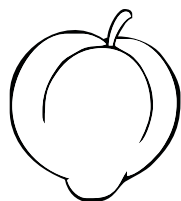

SS	S (COMEÇO)	S (MEIO) SOM DE Z
PÊSSEGO	SETE	LOUSA



## MAMÃE É UMA ROSA

MAMÃE É UMA ROSA  
QUE O PAPAÍ COLHEU.  
EU SOU O BOTÃOZINHO  
QUE A ROSEIRA DEU.

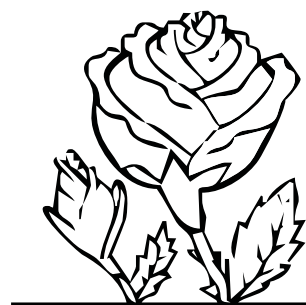

CIRCULE NO TEXTO ACIMA  
AS PALAVRAS **ROSA** E **ROSEIRA**.  
LEIA AS PALAVRAS DO QUADRO.

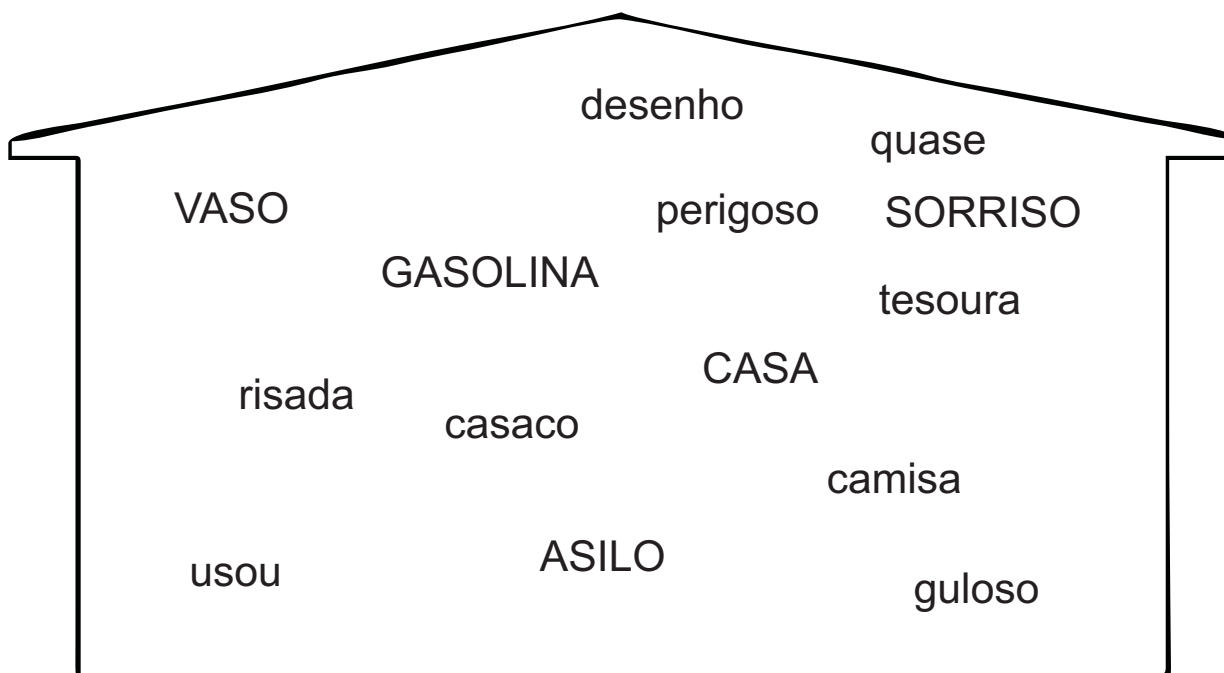



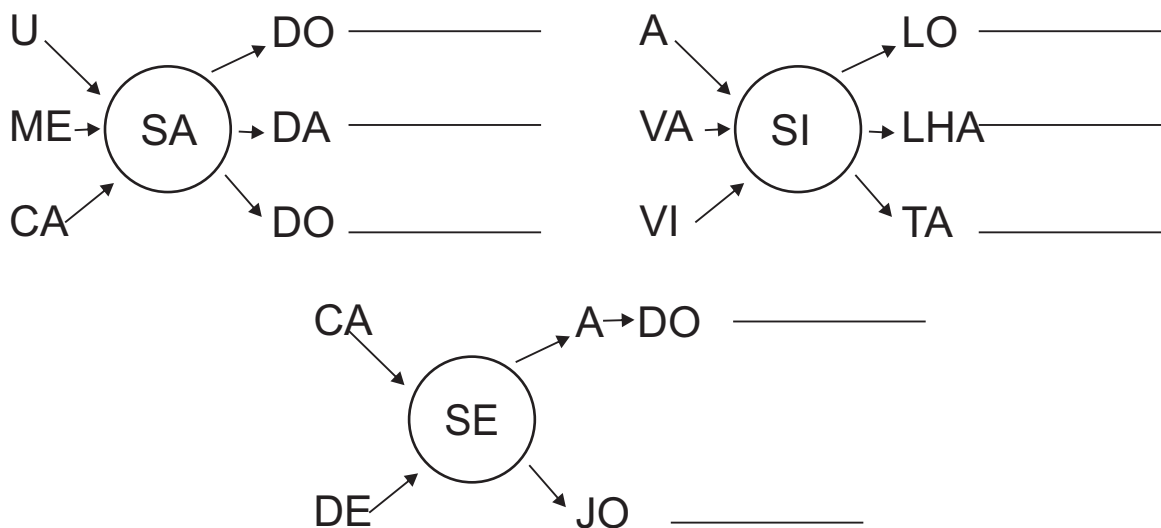

OBSERVE EM QUAIS PALAVRAS APARECE  
A LETRA **S**. ELA ESTÁ SEMPRE ENTRE  
AS VOGAIS E TEM O SOM MAIS FORTE.

PESQUISE EM JORNAIS E REVISTAS  
PALAVRAS QUE TEM A LETRA **S** COM  
O SOM DO **Z** IGUAL AO DA PALAVRA **CASA**.

JUNTE AS SÍLABAS E FORME PALAVRAS.



CIRCULE, NAS PALAVRAS, A SÍLABA QUE ESTÁ EM DESTAQUE NA COLUNA DOS DESENHOS.

 <div style="border: 1px solid black; padding: 2px; display: inline-block;">SA</div> <b>CASA</b>	CASARÃO ROSA CASACO BISAVÓ PESADO
 <div style="border: 1px solid black; padding: 2px; display: inline-block;">SE</div> <b>ROSEIRA</b>	RESERVA MUSEU DESEJO CAMISETA
 <div style="border: 1px solid black; padding: 2px; display: inline-block;">SI</div> <b>MÚSICA</b>	VISITA ASILO VASILHA CAMISA
 <div style="border: 1px solid black; padding: 2px; display: inline-block;">SO</div> <b>BESOURO</b>	VAGAROSO GULOSO JEITOSO GASOLINA PARAFUSO
 <div style="border: 1px solid black; padding: 2px; display: inline-block;">SU</div> <b>CASULO</b>	RESUMO JOSUÉ RASURA



LEIA AS PALAVRAS E COPIE-AS NO LUGAR INDICADO.

ROSA	TESOURO	AVISO	VAIDOSO
BESOURO	CAMISA	PARAFUSO	VASILHA
BISAVÔ	DESENHO	CASACO	CASULO
RISO	MÚSICA	ASA	VISITA
RASURA	ASILO	RESUMO	CAMISETA

SA	SE	SI

SO	SU

LEIA AS PALAVRAS E FORME OUTRAS  
COM AS SÍLABAS EM DESTAQUE.

CASACO CAMISA BARÃO	
VISEIRA VASILHA CAMISETA	
PENTE BESOURO ROSEIRA	
RAMO POTE CASA	
CASA MILHO DESEJO VISITA	
GATO CASO LIGA NAVE	

COM QUE LETRA VOCÊ VAI COMPLETAR AS PALAVRAS: **S**OU **Z**? LIGUE O DESENHO À PALAVRA.



VA\_\_O

RAPA\_\_

19



A\_\_EITE

BE\_\_OURO

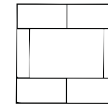

GA\_\_OLINA

DE\_\_ENOVE



A\_\_EITONA

RO\_\_A



TE\_\_OURO

A\_\_ULEJO



COMPLETE AS EXPRESSÕES COM AS PALAVRAS DO QUADRO.



TESOURO	GASOLINA	CASACO	CAMISA
AZEITE	PISO	PESO	ROSA
	AZULEJO	AZEITONA	TESOURA

\_\_\_\_\_ DE COURO

\_\_\_\_\_ DO PIRATA

\_\_\_\_\_ AFIADA

\_\_\_\_\_ DE OLIVA

\_\_\_\_\_ AMARELA

\_\_\_\_\_ BRANCO

\_\_\_\_\_ ADITIVADA

\_\_\_\_\_ PRETA

\_\_\_\_\_ LIGADA

\_\_\_\_\_ DO TIME

\_\_\_\_\_ MOLHADO

\_\_\_\_\_ PESADO

FORME FRASES COM AS PALAVRAS ABAIXO.

CASACO \_\_\_\_\_

RISADA \_\_\_\_\_

PARAFUSO \_\_\_\_\_

BISAVÓ \_\_\_\_\_

VISITA \_\_\_\_\_

FORME PALAVRAS, DE ACORDO COM OS NÚMEROS.

1	2	3	4	5	6	7	8	9	10	11
CA	TE	PO	RA	MI	BE	SA	RO	ME	SOU	CO

1 - 5 - 7

2 - 10 - 4

6 - 10 - 8

4 - 3 - 7

1 - 7

8 - 7

9 - 7

1 - 7 - 11

JUNTE AS SÍLABAS E FORME PALAVRAS.

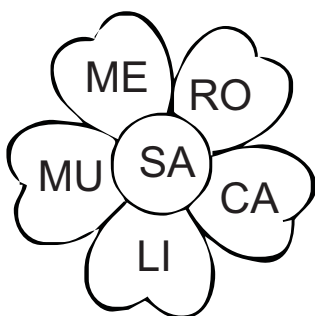

\_\_\_\_\_

\_\_\_\_\_

\_\_\_\_\_

\_\_\_\_\_

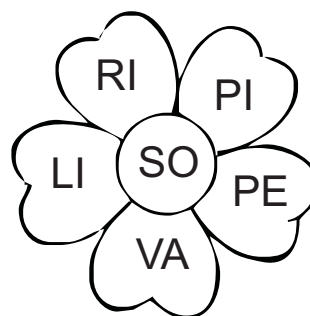

\_\_\_\_\_

\_\_\_\_\_

\_\_\_\_\_

\_\_\_\_\_

COMPLETE AS FRASES COM PALAVRAS DAS FICHAS.

MÚSICA -CASACO -GASOLINA -ISAURA

O \_\_\_\_\_ DE LÃ COR-DE-ROSA É DE \_\_\_\_\_.

AVISO- ROSA- TESOURA- LOUSA

O \_\_\_\_\_ FOI COLOCADO NA \_\_\_\_\_.

BISAVÔ -BESOURO -ROSA -RAPOSA

O \_\_\_\_\_ POUSOU NA \_\_\_\_\_.

VASO- MESA-ROSA -CAMISA

NO \_\_\_\_\_ TEM UMA \_\_\_\_\_ VERMELHA.

PARAFUSO -LISO -TESOURA- PISO

O \_\_\_\_\_ DA \_\_\_\_\_ CAIU NO CHÃO.

ORDENE AS SÍLABAS E ESCREVA AS PALAVRAS.

SI	CA	NHA

CA	SA	CO

SA	CA	MI

RA	PA	SO	FU

NA	LI	SO	GA

DA	RI	SA

LO	GU	SO

DE	NHO	SE

**CAÇA - PALAVRAS**

XA	QUE	RO	A	VI	SO	TU	ME
RA	PO	SA	CA	SI	CO	CA	SA
ZA	WA	ZU	MI	TA	FA	SA	GE
QUA	VA	TI	SA	ZO	BU	CO	XU
RI	SO	GI	BI	SA	VÓ	FU	MU
NE	HA	GA	SO	LI	NA	GUÊ	GUI

- CAMISA
- BISAVÓ
- CASACO
- RAPOSA
- ROSA
- VISITA
- AVISO
- VASO
- RISO
- GASOLINA
- CASA
- MESA

RECORTE AS FICHAS, LEIA AS PALAVRAS E  
COLE-AS DE ACORDO COM A INDICAÇÃO DA COLUNA.

CE			
CI			
Ç			
S			
SS			
S PÓS VOCÁLICO			
S SOM Z			
Z			
SINO	OSSO	CASA	CEGO
GASOLINA	CIDADE	ESCOLA	CASCA
CAÇULA	PÁSSARO	AZEITE	CINEMA
SAPO	ZEBRA	CIDADÃO	COZINHA
CEBOLA	CAÇAROLA	SONO	HISTÓRIA
PALHAÇO	ASSEIO	CEDO	BISAVÔ

A LETRA É A MESMA  
 MAS O SOM PODE MUDAR.  
 ELE IMITA A LETRA **S**  
 EM EXPLODE E EXPLORAR.

**X = S**

LEIA

EXPLICAR	EXCURSÃO	EXPLOÇÃO	EXPLORAR
TEXTO	EXTERIOR	EXPERIÊNCIA	EXPRESSÃO
EXCESSO	EXPOSIÇÃO	EXCESSIVO	EXCEÇÃO
EXPRIMIR	EXTERNATO	EXPRESSO	SEXTA-FEIRA

CIRCULE AS SÍLABAS COM **X**,  
 NAS PALAVRAS DO QUADRO.

DEPOIS, SEPRE AS SÍLABAS DAS PALAVRAS.

EXCURSÃO	EXPLOÇÃO	EXTERNATO	EXCEÇÃO

ESCOLHA TRÊS PALAVRAS DO QUADRO,  
 ESCREVA NAS FICHAS E FORME FRASES.

<input type="text"/>	_____
<input type="text"/>	_____
<input type="text"/>	_____

LIGUE E FORME PALAVRAS.

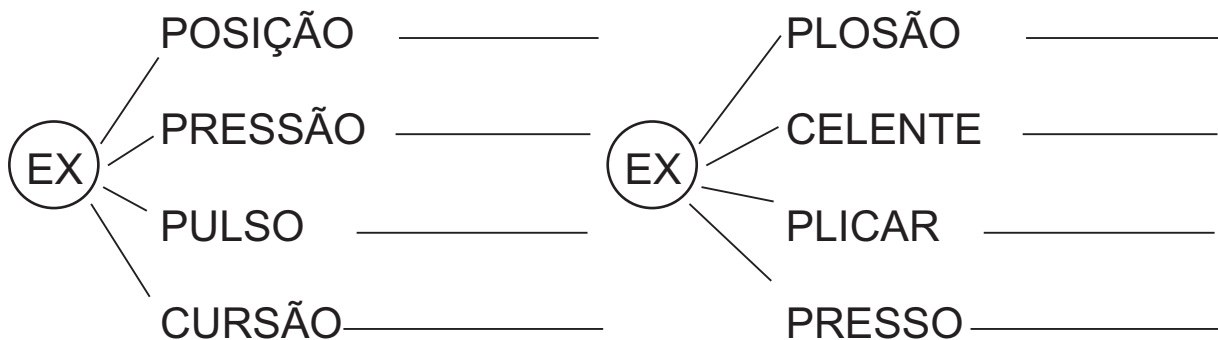

A LETRA É A MESMA  
 MAS O SOM PODE MUDAR.  
 ELA IMITA AS LETRAS **SS**  
 EM TROUXE, PRÓXIMO E AUXILIAR.

# X=SS

LEIA

PRÓXIMO	MÁXIMO	TROUXE	AUXÍLIO
AUXILIAR	TROUXER	PROXIMIDADE	PRÓXIMA
APROXIMAR	AUXILIA		

CIRCULE AS SÍLABAS COM **X**, NAS PALAVRAS ACIMA.

ESCREVA QUATRO PALAVRAS NAS  
 FICHAS ABAIXO, SEPARANDO-AS EM SÍLABAS.

--	--	--	--	--	--	--	--	--	--	--

ESCREVA PALAVRAS DE ACORDO COM AS FIGURAS.



○ \_\_\_\_\_  
 □ \_\_\_\_\_

⬡ \_\_\_\_\_

COLOQUE **X** NAS FICHAS DAS PALAVRAS  
 QUE TÊM A LETRA **X** COM O SOM DE **SS**.

	EXCURSÃO		TROUXE		EXAGERO
	BRUXA		EXCESSO		PRÓXIMO
	EXAME		AUXÍLIO		PEIXE
	MÁXIMO		FIXO		APROXIMAR

A LETRA É A MESMA,  
MAS O SOM PODE MUDAR.  
ELA IMITA A LETRA **Z**  
EM ÊXITO, EXERCÍCIO E  
EXEMPLAR.

**X=Z**

LEIA.

EXÉRCITO	ÊXITO	EXEMPLAR	EXATIDÃO
EXECUTAR	EXIBIR	EXAUSTO	EXATO
EXISTÊNCIA	EXAME	EXAGERO	EXISTIR
EXIGENTE	EXERCÍCIO	EXAGERADO	EXEMPLO
EXECUTA	EXAMINAR	EXISTE	EXAGEROU

CIRCULE AS SÍLABAS COM **X** NAS PALAVRAS ACIMA.

ESCOLHA QUATRO PALAVRAS, COPIE  
NAS FICHAS ABAIXO E SEPRE-AS EM SÍLABAS.

DESEMBARALHE AS SÍLABAS E FORME AS PALAVRAS.

TE	XIS	E		TO	E	CI	XÉR		XEM	E	PLO

PINTE SOMENTE AS FICHAS DAS PALAVRAS  
EM QUE O **X** TEM O SOM DE **Z**.

BRUXA	EXISTIU	EXCURSÃO	EXAME
EXEMPLAR	BOXE	EXIGIR	TÓRAX
TROUXE	EXÉRCITO	XAMPU	EXIBIÇÃO



A LETRA É A MESMA  
 MAS O SOM PODE MUDAR.  
 ELE IMITA AS LETRAS **CH**  
 EM ENXADA, GRAXA E ENXUGAR.

# X=CH

LEIA

XAMPU	XAROPE	BRUXA	TROUXA
XALE	XÍCARA	PEIXE	AMEIXA
GRAXA	XARA	XERETA	LIXO
ROXO	LIXEIRA	EMBAIXO	CAIXA
QUEIXO	ENXAME	FAXINEIRA	ENGRAXATE

CIRCULE AS SÍLABAS COM **X**, NAS PALAVRAS DO QUADRO

ESCOLHA QUATRO PALAVRAS DO QUADRO,  
 ESCREVA NAS FICHAS E FORME FRASES.

	_____
	_____
	_____
	_____

FORME PALAVRAS, SUBSTITUINDO OS  
 NÚMEROS PELAS SÍLABAS CORRESPONDENTES.

1 XA	2 XE	3 XO	1 - 8 - 11	2 - 6 - 10
4 QUEI	5 TE	6 RE	9 - 1	9 - 3
7 RÁ	8 RO	9 LI	8 - 3	12 - 1
10 TA	11 PE	12 BRU	1 - 7	4 - 3
			3 - 5	4 - 1

A LETRA É A MESMA  
 MAS O SOM PODE MUDAR.  
 ELE IMITA AS LETRAS **CS**  
 EM TAXÍ, AXILA E MAXILAR.

# X=CS

LEIA AS PALAVRAS DO QUADRO.

CRUCIFIXO	DUREX	FIXO	SEXO
BOXE	AXILA	ASFIXIAR	REFLEXO
FIXAR	TÓXICO	MAXILAR	FLEXIONAR
INTOXICA	COMPLEXO	FLEXÍVEL	SAXOFONE
REX	MAX	ASTERIX	LÁTEX

CIRCULE NO QUADRO AS SÍLABAS  
 ONDE A LETRA **X** TEM O SOM DE **CS**.

LIGUE OS DESENHOS ÀS  
 PALAVRAS CORRESPONDENTES.

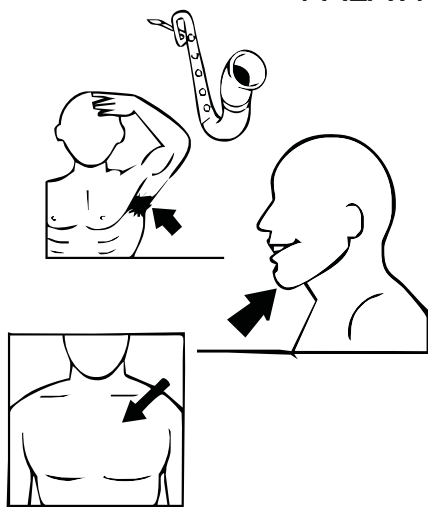

- AXILA
- BOXE
- MAXILAR
- SAXOFONE
- CRUCIFIXO
- REFLEXO
- LÁTEX
- TÓRAX



COMPLETE AS PALAVRAS, ESCRIVENDO  
 AS SÍLABAS COM O **X** = SOM **CH**.







FI \_\_\_\_\_ TÓ \_\_\_\_\_ CO REFLE \_\_\_\_\_

SA \_\_\_\_\_ FONE COMPLE \_\_\_\_\_ CRUCIFI \_\_\_\_\_

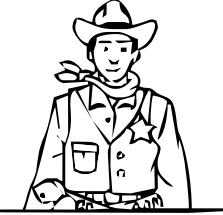
SE \_\_\_\_\_ INTO \_\_\_\_\_ CADO BO \_\_\_\_\_

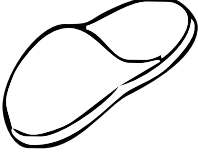
a q u b A C S Z m X N O P C G V

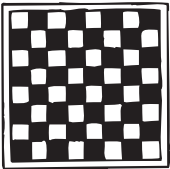
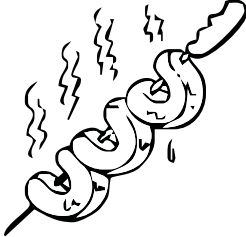
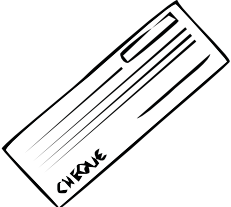
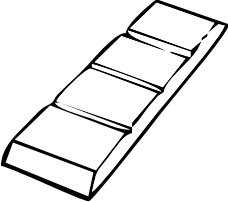
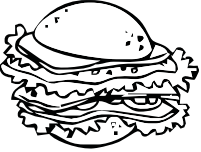
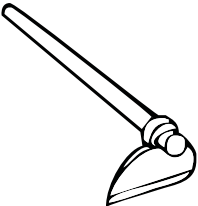
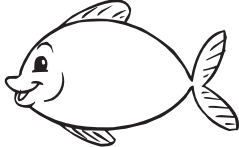
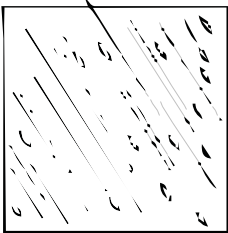
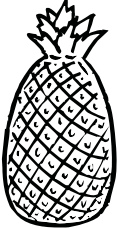
PINTE OS DESENHOS CUJOS NOMES SÃO ESCRITOS  
POR **X** E CIRCULE OS DESENHOS CUJAS  
PALAVRAS SÃO ESCRITAS COM **CH**.

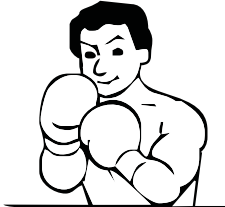
C b v h A B q A C u z m O X

a q u b A C S Z m X N O P C G V  
 p c c u z o v g o s a s u q h z s p r D A m o v p n  
 h c h c b v h a B q A C u z m o X

ESCREVA AS PALAVRAS NA COLUNA CERTA.

TROUXE	XÍCARA	EXPLICA	ASFIXIA	EXERCÍCIO
AUXILIOU	EXPLORAR	EXATA	EXEMPLO	TÁXI
PEIXE	XERETA	MÁXIMO	EXPOSIÇÃO	BOXE

X=Z	X=S	X=CS
X=SS	X=CH	

VAMOS FORMAR PALAVRAS?

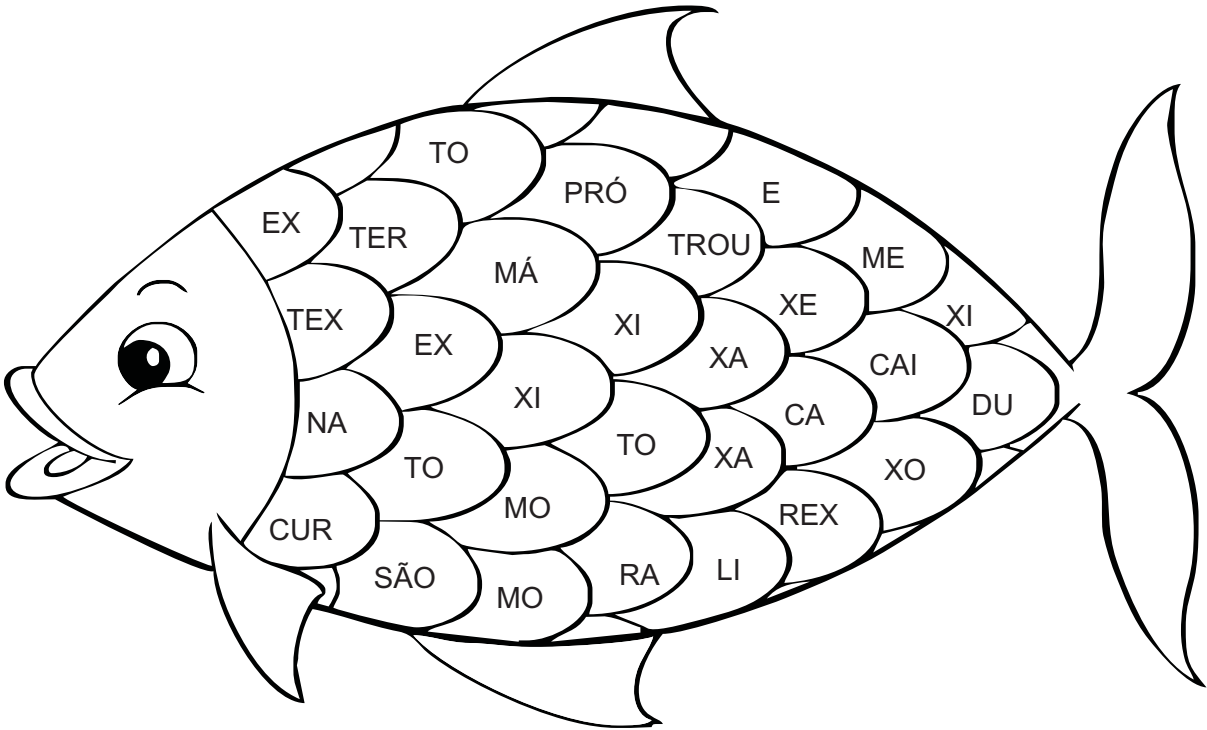



---



---

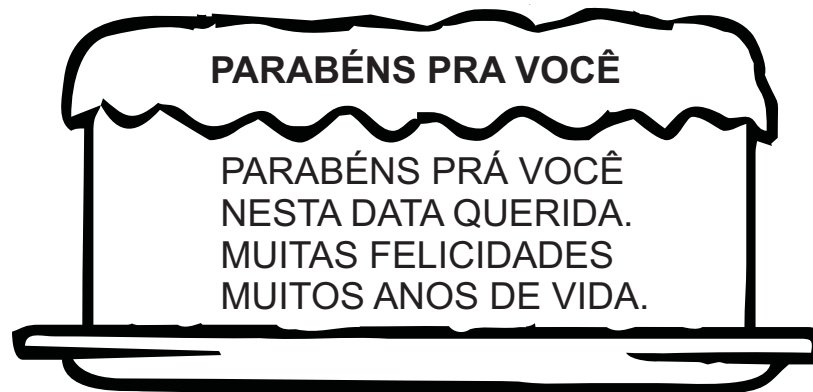

---



CIRCULE NO TEXTO A PALAVRA **PARABÉNS**.  
OBSERVE QUE A PALAVRA PARABÉNS TERMINA EM **NS**.

LEIA OUTRAS PALAVRAS QUE TAMBÉM TÊM **NS**.

MONSTRO	CONSTRUÇÃO	TRANSPORTE	NUVENS
INSPETOR	PARABÉNS	INSTRUMENTO	VIAGENS
TRANSPARENTE	PATINS	TRANSFORMAR	PASSAGENS
RUBENS	CONSTANÇA	TRANSPIRAR	SONS

CIRCULE NAS PALAVRAS DO QUADRO AS SÍLABAS COM **NS**.  
COPIE.

ans - ens - ins - ons - uns

\_\_\_\_\_

SIGA O MODELO E ESCREVA O PLURAL DAS PALAVRAS.

BEM - BENS

SOM - SONS

JARDIM - \_\_\_\_\_

TREM - \_\_\_\_\_

HOMEM - \_\_\_\_\_

UM - \_\_\_\_\_

BOMBOM - \_\_\_\_\_

ALGUM - \_\_\_\_\_

PINGÜIM - \_\_\_\_\_

VIAGEM - \_\_\_\_\_

ÁLBUM - \_\_\_\_\_

BOM - \_\_\_\_\_

PATIM - \_\_\_\_\_

VAGEM - \_\_\_\_\_

COMPLETE AS FRASES COM PALAVRAS DO QUADRO.

TRENS PAISAGENS PATINS FOLHAGENS  
VIAGENS TRANSPORTE PUDINS PINGÜINS

OS \_\_\_\_\_ SÃO ANIMAIS QUE VIVEM EM REGIÕES GELADAS.

TODOS OS DIAS VOVÓ CUIDA DE SUAS \_\_\_\_\_.

RUBENS É MAQUINISTA DE \_\_\_\_\_. ELE CUIDA DO \_\_\_\_\_ DE  
PESSOAS.

ELE GOSTA DE BRINCAR COM O SEU PAR DE \_\_\_\_\_.

NAS \_\_\_\_\_ DE TREM É MUITO AGRADÁVEL APRECIAR  
AS \_\_\_\_\_.

A COZINHEIRA FEZ DOIS \_\_\_\_\_, UM DE LEITE E OUTRO  
DE CHOCOLATE.

SEPARE AS PALAVRAS EM SÍLABAS E DEPOIS COPIE-AS.

PATINS	FOLHAGENS	PUDINS

TRANSPORTE	PAISAGENS

BOMBONS	JARDINS	ÁLBUNS

ESCREVA O NOME DAS FIGURAS.

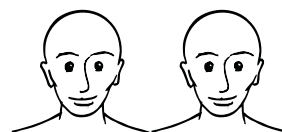
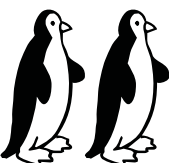

ORDENE AS SÍLABAS E COPIE AS PALAVRAS.

BÉNS	PA	RA	POR	TRANS	TE	ÇÃO	TRU	CONS
------	----	----	-----	-------	----	-----	-----	------

TRU	INS	TO	MEN	INS	DO	MEN	A
-----	-----	----	-----	-----	----	-----	---

GENS	VI	A	BONS	BOM	DINS	JAR
------	----	---	------	-----	------	-----

ESCREVA 3 PALAVRAS QUE TERMINEM COM AS SÍLABAS INDICADAS NOS QUADROS.

ANS	ENS	INS	ONS	UNS

## MEU LANCHINHO

MEU LANCHINHO,  
MEU LANCHINHO  
VOU COMER, VOU COMER.  
PRA FICAR FORTINHO  
PRA FICAR FORTINHO  
E CRESCER, E CRESCER.

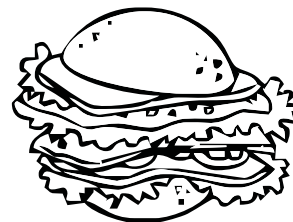

CD AS MAIS BELAS CANTIGAS DE RODA.  
CIRANDA CULTURAL, pág. 30)

CIRCULE NO TEXTO A PALAVRA **CRESCER**.

COPIE A PALAVRA QUE VOCÊ CIRCULOU.

CRESCER -

crescer -

COMPLETE COM **SC** AS PALAVRAS ABAIXO.

NA\_\_ER

FA\_\_ÍCULO

PI\_\_INA

DI\_\_IPLINA

NA\_\_IMENTO

CRE\_\_IMENTO

CRE\_\_ER

CON\_\_IENTE

ADOLE\_\_ENTE

ACRE\_\_ENTAR

CON\_\_IÊNCIA

FLORE\_\_ER

DE\_\_ER



JUNTE AS SÍLABAS E ESCREVA AS PALAVRAS.

DES	CEU	PIS	CI	NA	NAS	CI	MEN	TO
-----	-----	-----	----	----	-----	----	-----	----

A	DO	LES	CEN	TE	NAS	CEU	DES	CI	DA
---	----	-----	-----	----	-----	-----	-----	----	----

JUNTE AS SÍLABAS E ESCREVA AS PALAVRAS FORMADAS.

DES	PIS	1 - 3 - 6	11 - 7
CRES	DA	_____	_____
TE	CI	5 - 3 - 2	4 - 9
CEU	NAS	_____	_____
CEN	DES	4 - 7	11 - 8 - 10
CER	NA	_____	_____

SUBSTITUA OS NÚMEROS PELAS SÍLABAS E FORME PALAVRAS.

CRESCER	NASCIMENTO	DESCER

ADOLESCENTE	FASCÍCULO

LIGUE AS SÍLABAS E ESCREVA AS PALAVRAS.

DES	→	CER	_____				
	→	CI	→	DA	_____		
		CRES	→	CI	→	DO	_____
			→	MEN	→	TO	_____

VAMOS VER QUEM CONSEGUE  
LER AS PLACAS ?

ABDOMEM  
OBTER

OBJETO  
OBSERVAÇÃO

SUBMARINO  
TÉCNICO

CACTO  
PACTO

ADVOGADO  
ADVERSÁRIO

ADMIRADO  
AFTA

SIGNO  
MAGNÍFICO

PNEU  
PNEUMONIA

HELICÓPTERO  
RAPTO

ATMOSFERA  
RECEPÇÃO

COPIE AS PALAVRAS QUE VOCÊ LEU EM SEU  
CADERNO E SEPRE-AS EM SÍLABAS.

LEIA AS PALAVRAS DO QUADRO E DEPOIS  
COPIE-AS, DE ACORDO COM O QUE SE PEDE.

OBTER	ADVOGADO	AFTA	ADMIRADO
CACTO	OBSERVAR	HELICÓPTERO	SIGNO
ADJETIVO	TÉCNICO	OBTURAÇÃO	ABSURDO
PNEU	ADMIRAR	ADVERSÁRIO	OBJETO
SIGNIFICA	PNEUMONIA	SUBMARINO	MAGNÍFICO
SUBTRAIR	RAPTO	ATMOSFERA	PACTO

LETRA B	LETRA C	LETRA D	LETRA F
_____	_____	_____	_____
_____	_____	_____	
_____	_____	_____	
_____	_____	_____	
_____		_____	
_____		_____	

LETRA G	LETRA P	LETRA T
_____	_____	_____
_____	_____	
_____	_____	
	_____	

ESCOLHA 3 PALAVRAS DO QUADRO E FORME FRASES.

	_____
	_____
	_____

ESCREVA NOS BALÕES PALAVRAS QUE CONTENHAM AS LETRAS MUDAS, INDICADAS NAS ETIQUETAS.

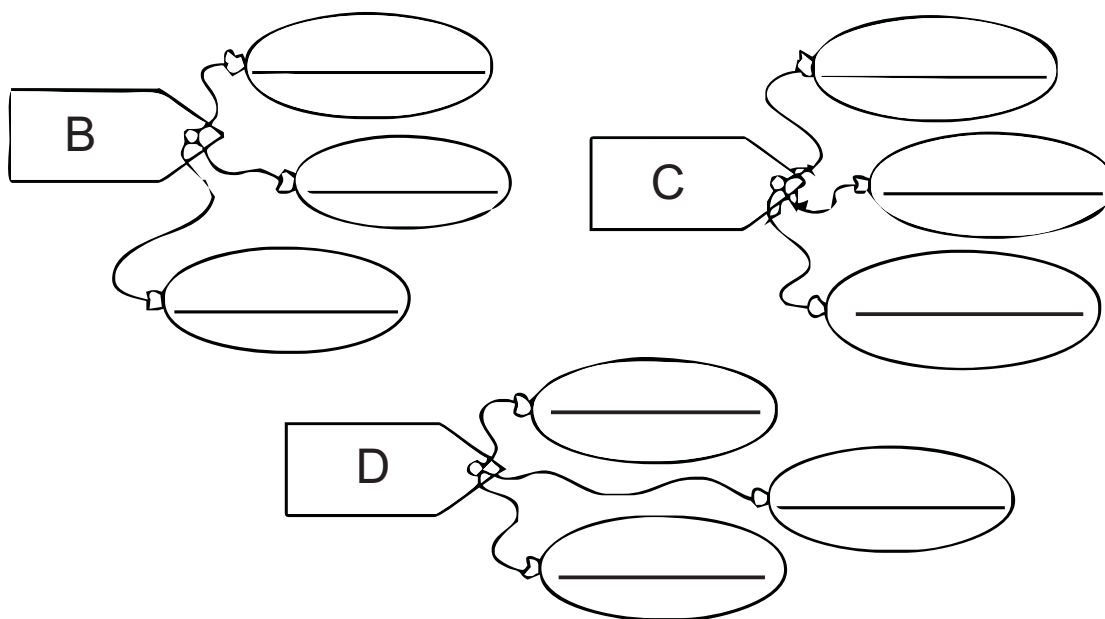

ENCONTRE AS SÍLABAS, NO DIAGRAMA, QUE FORMAM ESTAS PALAVRAS. PARA CADA PALAVRA FORMADA, UTILIZE UMA COR.

OBJETO ADVOGADO TÉCNICO OBTER  
AFTA OBTURAÇÃO RAPTO CACTO SIGNO

OB	AD	OB	TA	RAP	SIG	OB	TÉC
VO	JE	AF	TU	TO	ÇÃO	NI	TER
GA	DO	TO	CAC	RA	TO	NO	CO

VEJA O QUADRO DE PALAVRAS. NELE ESTÁ ESCRITO  
 PALAVRAS COM AS LETRAS **K** - **W** - **Y**. COPIE EM  
 SEU CADERNO, SEPARANDO POR GRUPOS - LETRAS **K** - **W** - **Y**.

FRANKLIN	KISABOR	MICKEY
KODAK	DIET COKE	KENNEDY
KG	KIT	WILSON
KM	KETCHUP	DISNEY
SEIKO	CLOCK	NEWTON
KIBON	QUAKER	NOVA YORK
KITANO	WAGNER	COUNTRY
SHOW	EVEREADY	TWIST
COWBOY	QUALY	CYPOL
AYMOREÉ	KOLYNOS	YOKI

ESCREVA AS PALAVRAS ACIMA, AGRUPANDO-AS  
 DE ACORDO COM A LETRA INDICADA.

K	W	Y

PESQUISE OUTRAS PALAVRAS COM ESSAS LETRAS.

SOU A LETRA **K**. APAREÇO EM MUITAS PALAVRAS E TENHO O SOM DE **C** E **Q**.

COPIE

k - \_\_\_\_\_

k - \_\_\_\_\_

K - \_\_\_\_\_

K - \_\_\_\_\_

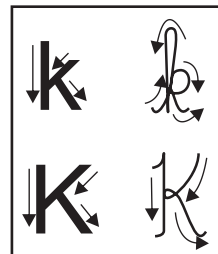

RECORTE AS FICHAS E COLE-AS, DE ACORDO COM O QUE SE PEDE. PESQUISE OUTRAS PALAVRAS COM A LETRA **K**.

NOMES FEMININOS	_____
NOMES MASCULINOS	_____

RECORTE AS FICHAS E COLE-AS, DE ACORDO COM OS DESENHOS.

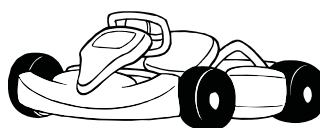
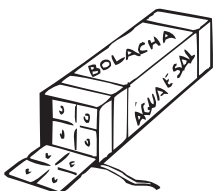
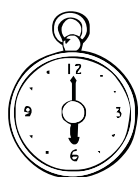

SEIKO	KG	KM	KART
KOLYNOS	KIBON	KETCHUP	CREAM CRACKER

SOU A LETRA **W**. APAREÇO EM MUITAS PALAVRAS E TENHO O SOM DE **V** NAS PALAVRAS DE ORIGEM ALEMÃ; E DE **U** NAS DE ORIGEM INGLESA.

**W** - \_\_\_\_\_  
**w** - \_\_\_\_\_  
**W** - \_\_\_\_\_  
**w** - \_\_\_\_\_

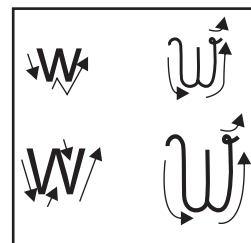

RECORTE E COLE AS FICHAS, DE ACORDO COM OS DESENHOS. PESQUISE OUTROS NOMES COM A LETRA **W**.

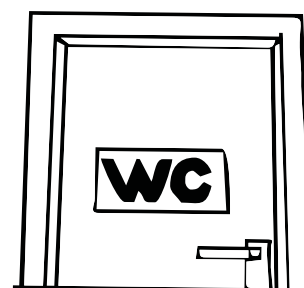
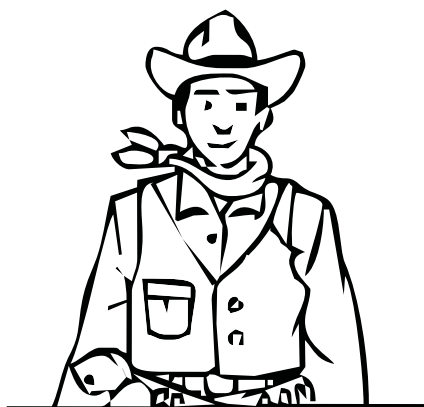
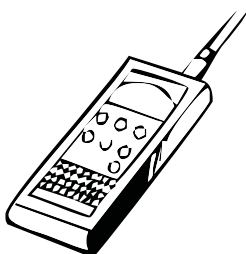

WALK-TALK	COWBOY	WC
TWIST	WALITA	WALL MART

SOU A LETRA **Y**. APAREÇO EM MUITAS  
PALAVRAS E TENHO O SOM DE **Í**.

COPIE.

y -

y -

Y -

y -

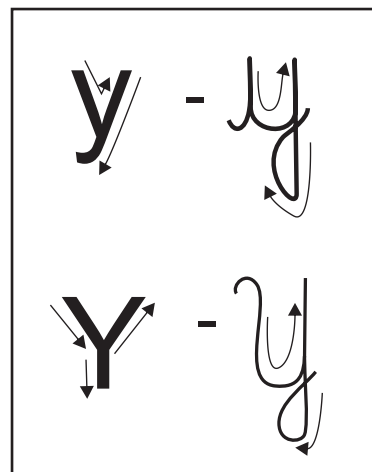

RECORTE AS FICHAS E COLE-AS, DE ACORDO COM O  
QUE SE PEDE. PESQUISE OUTROS NOMES COM A LETRA **Y**.



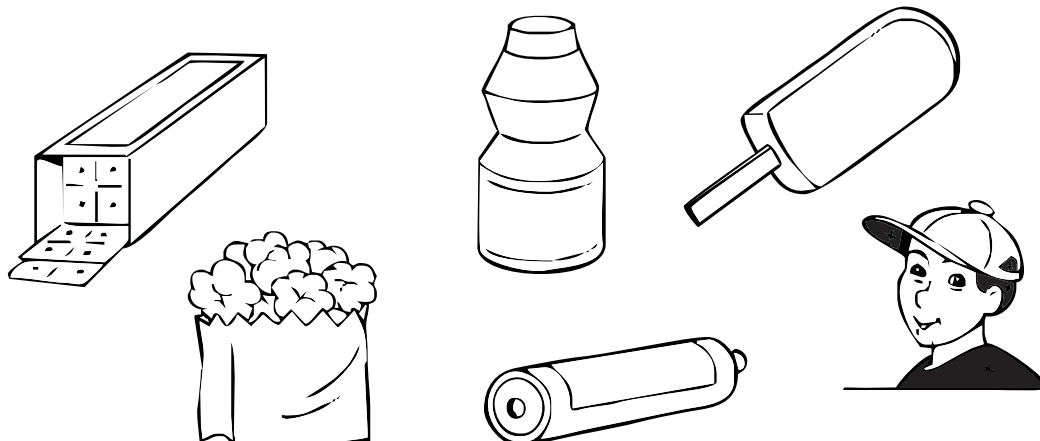











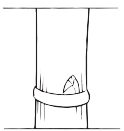

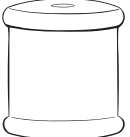
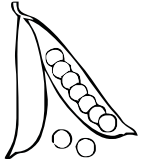



NOMES FEMININOS	
NOMES MASCULINOS	

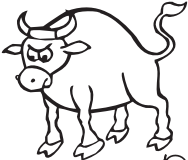



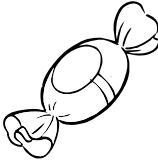









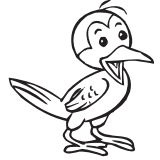

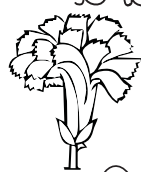

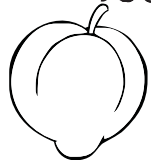

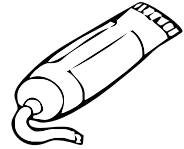

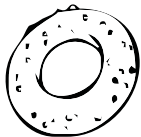
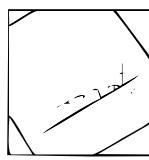
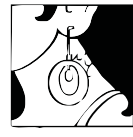
YOPA	AYMORÉ	YOKI
EVEREADY	YURI	YAKULT

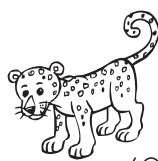
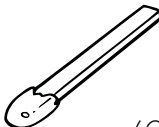











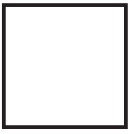

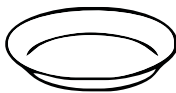

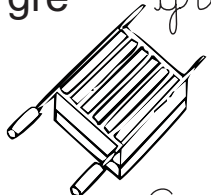
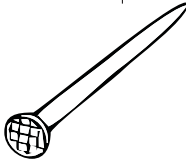
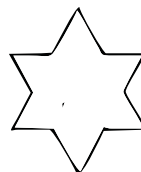
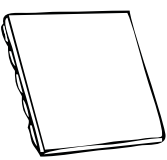

# SILABÁRIO

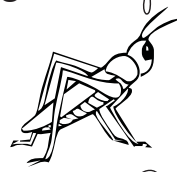
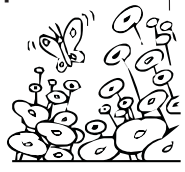
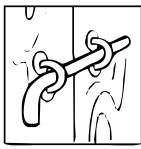
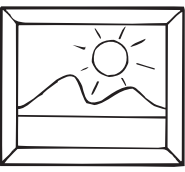
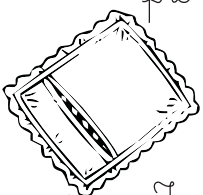
<p>ra ra</p>  <p>Ra Ra</p>	<p>rra rra</p>  <p>RRA RRA</p>	<p>ar ar</p>  <p>Ar Ar</p>	<p>al al</p>  <p>Al Al</p>	<p>am am</p>  <p>Am Am</p>
<p>re re</p>  <p>Re Re</p>	<p>rre rre</p>  <p>RRE RRE</p>	<p>er er</p>  <p>Er Er</p>	<p>el el</p>  <p>El El</p>	<p>em em</p>  <p>Em Em</p>
<p>ri ri</p>  <p>Ri Ri</p>	<p>rri rri</p>  <p>RRI RRI</p>	<p>ir ir</p>  <p>Ir Ir</p>	<p>il il</p> <p>1000</p> <p>Il Il</p>	<p>im im</p>  <p>Im Im</p>
<p>ro ro</p>  <p>Ro Ro</p>	<p>rro rro</p>  <p>RRO RRO</p>	<p>or or</p>  <p>Or Or</p>	<p>ol ol</p>  <p>Ol Ol</p>	<p>om om</p>  <p>Om Om</p>
<p>ru ru</p>  <p>Ru Ru</p>	<p>rru rru</p>  <p>RRU RRU</p>	<p>ur ur</p>  <p>Ur Ur</p>	<p>ul ul</p> <p>AZUL</p> <p>Ul Ul</p>	<p>um um</p>  <p>Um Um</p>

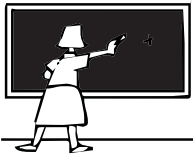





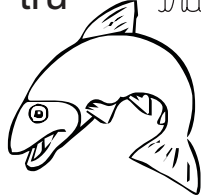







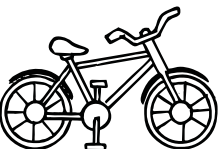
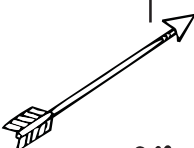
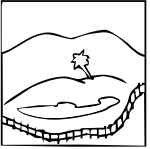
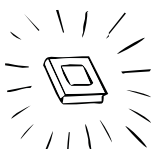
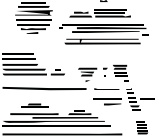

# SILABÁRIO

<p>an an</p>  <p>An An</p>	<p>as as</p>  <p>As As</p>	<p>ssa ssa</p>  <p>SSA</p>	<p>bra bra</p>  <p>BRA Bra</p>	<p>cra cra</p>  <p>CRA Cra</p>
<p>en en</p>  <p>En En</p>	<p>es es</p>  <p>Es Es</p>	<p>sse sse</p>  <p>SSE</p>	<p>bre bre</p>  <p>BRE Bre</p>	<p>cre cre</p>  <p>CRE Cre</p>
<p>in in</p>  <p>In In</p>	<p>is is</p>  <p>Is Is</p>	<p>ssi ssi</p>  <p>SSI</p>	<p>bri bri</p>  <p>BRI Bri</p>	<p>cri cri</p>  <p>CRI Cri</p>
<p>on on</p>  <p>On On</p>	<p>os os</p>  <p>Os Os</p>	<p>ssO ssO</p>  <p>SSO</p>	<p>bro bro</p>  <p>BRO Bro</p>	<p>cro cro</p>  <p>CRO Cro</p>
<p>un un</p>  <p>U Un</p>	<p>us us</p>  <p>Us Us</p>	<p>ssu ssu</p>  <p>SSU</p>	<p>bru bru</p>  <p>BRU Bru</p>	<p>cru cru</p>  <p>CRU Cru</p>

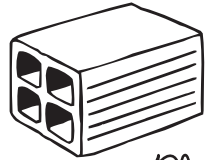

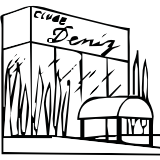

# SILABÁRIO

<p>dra dra</p>  <p>DRA Dra</p>	<p>fra fra</p>  <p>FRA Fra</p>	<p>gra gra</p>  <p>GRA Gra</p>	<p>pra pra</p>  <p>PRA Pra</p>	<p>tra tra</p>  <p>TRA Tra</p>
<p>dre dre</p>  <p>DRE Dre</p>	<p>fre fre</p>  <p>FRE Fre</p>	<p>gre gre</p>  <p>GRE Gre</p>	<p>pre pre</p>  <p>PRE Pre</p>	<p>tre tre</p>  <p>TRE Tre</p>
<p>dri dri</p>  <p>DRI Dri</p>	<p>fri fri</p>  <p>FRI Fri</p>	<p>gri gri</p>  <p>GRI Gri</p>	<p>pri pri</p>  <p>PRI Pri</p>	<p>tri tri</p>  <p>TRI Tri</p>
<p>dro dro</p>  <p>DRO Dro</p>	<p>fro fro</p>  <p>FRO Fro</p>	<p>gro gro</p>  <p>GRO Gro</p>	<p>pro pro</p>  <p>PRO Pro</p>	<p>tro tro</p>  <p>TRO Tro</p>
<p>dru dru</p>  <p>DRU Dru</p>	<p>fru fru</p>  <p>FRU Fru</p>	<p>gru gru</p>  <p>GRU Gru</p>	<p>pru pru</p>  <p>PRU Pru</p>	<p>tru tru</p>  <p>TRU Tru</p>

# SILABÁRIO

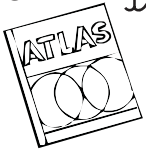
<p>vra vra</p>  <p>VRA Ura</p>	<p>bla bla</p>  <p>BLA Bla</p>	<p>cla cla</p>  <p>CLA Cla</p>	<p>fla fla</p>  <p>FLA Fla</p>	<p>gla gla</p>  <p>GLA Gla</p>
<p>vre vre</p>  <p>VRE Ure</p>	<p>ble ble</p>  <p>BLE Ble</p>	<p>cle cle</p>  <p>CLE Cle</p>	<p>fle fle</p>  <p>FLE Fle</p>	<p>gle gle</p>  <p>GLE Gle</p>
<p>vri vri</p>  <p>VRI Uri</p>	<p>bli bli</p>  <p>BLI Bli</p>	<p>cli cli</p>  <p>CLI Cli</p>	<p>fli fli</p>  <p>FLI Fli</p>	<p>gli gli</p>  <p>GLI Gli</p>
<p>vro vro</p>  <p>VRO Uro</p>	<p>blo blo</p>  <p>BLO Blo</p>	<p>clo clo</p>  <p>CLO Clo</p>	<p>flo flo</p>  <p>FLO Flo</p>	<p>glo glo</p>  <p>GLO Glo</p>
<p>X</p>	<p>blu blu</p>  <p>BLU Blu</p>	<p>clu clu</p>  <p>CLU Clu</p>	<p>flu flu</p>  <p>FLU Flu</p>	<p>glu glu</p>  <p>GLU Glu</p>

# SILABÁRIO

<p>pla      <i>pla</i></p>  <p>PLA      <i>Pla</i></p>	<p>tla      <i>tla</i></p>  <p>TLA</p>			
<p>ple      <i>ple</i></p> <p>PLENO</p> <p>PLE      <i>Ple</i></p>	<p>tle      <i>tle</i></p>  <p>TLE</p>			
<p>pli      <i>pli</i></p>  <p>PLI      <i>Pli</i></p>	<p>tli      <i>tli</i></p> <p>TLI</p>			
<p>plo      <i>plo</i></p>  <p>PLO      <i>Plo</i></p>	<p>tlo      <i>tlo</i></p> <p>TLO</p>			
<p>plu      <i>plu</i></p>  <p>PLU      <i>Plu</i></p>				