

A coleção “CIRANDA DAS SÍLABAS” é composta por seis volumes, organizados em lições que apresentam atividades seqüenciais. Nos volumes 1 e 2, as lições envolvem o trabalho com vogais e consoantes, facilitando o aprendizado do alfabeto. Os demais volumes estão voltados à sistematização das famílias silábicas, permitindo, dessa maneira, que o professor avalie sistematicamente os avanços de seus alunos, fazendo intervenções adequadas ao perceber que algum aluno não está aprendendo de forma satisfatória.

Ruth Rozendo Caputo



CIRANDA DAS

Sí-lab-as

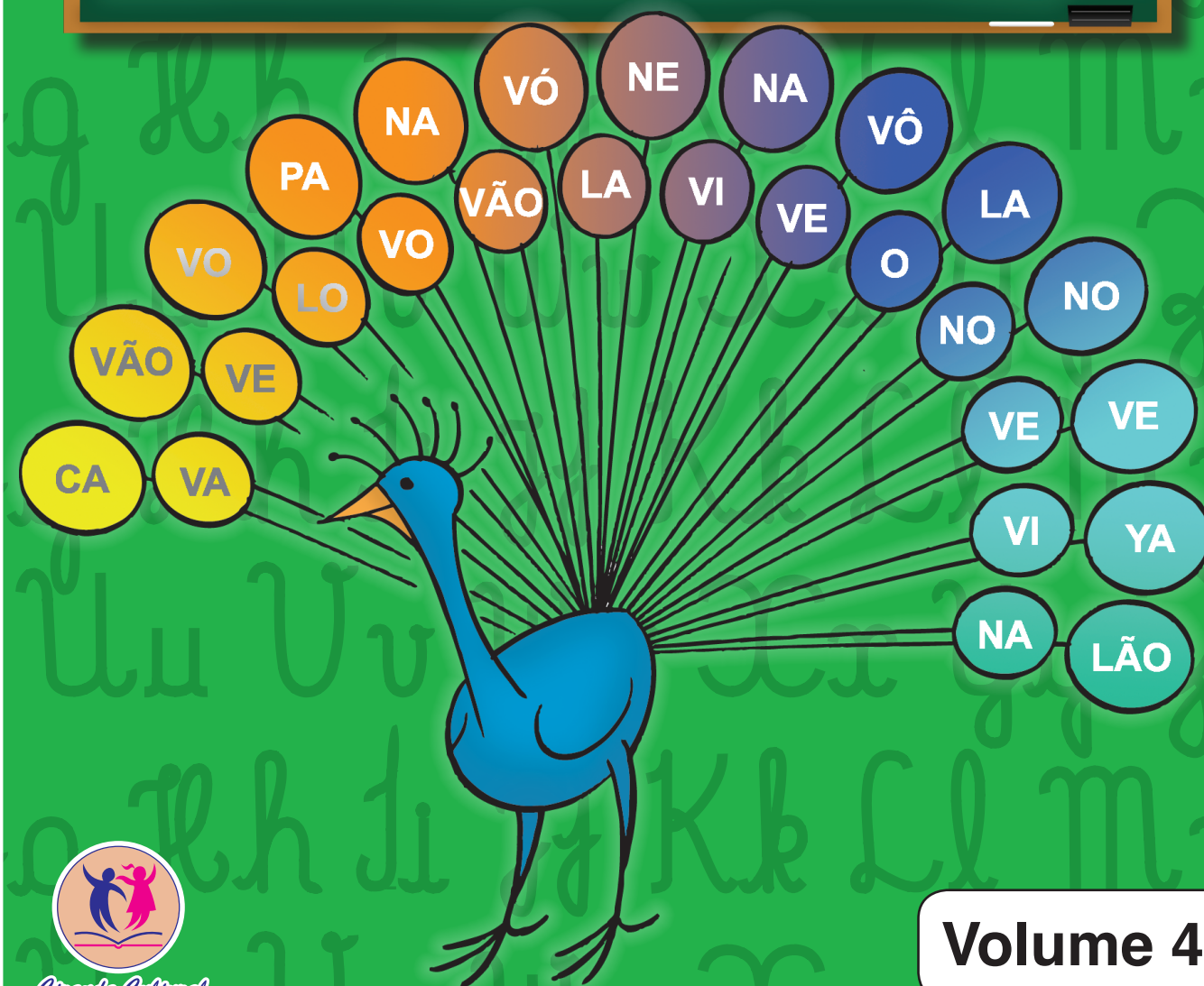

Volume 4

a q u b A C S z m X N O p c g V

p
c
v
o
g
s
a
s
u
D
q
N
G
c
h

g
a
s
u
q
h
z
s
p
r
D
A
m
O
V
p
N

CANTIGA

NANA NENÊ,
QUE A CUCA VEM PEGAR.
PAPAI FOI NA ROÇA,
MAMÃE NO CAFEZAL.



TUTU MARAMBÁ
NÃO VENHAS MAIS CÁ,
QUE O PAI DO MENINO
TE MANDA MATAR.

DOMÍNIO PÚBLICO

COPIE A PALAVRA.

NENÊ _____

nenê _____

nenê _____

COPIE A LETRA **N - n.**

N _____

n _____

n _____

n _____

C b v H a B q A C u z m O X

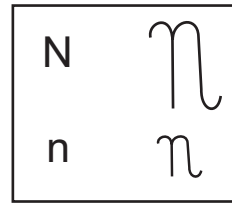
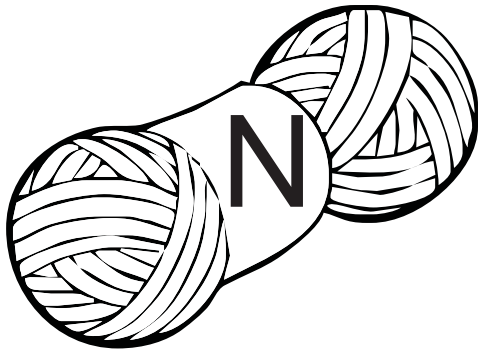

JUNTE A LETRA **N - n** COM AS VOGAIS E
FORME A FAMÍLIA SILÁBICA.

+	A	E	I	O	U
N					

COPIE.

NA - NE - NI - NO - NU

Na - Ne - Ni - No - Nu

+	a	e	i	o	u	ão
n						

na - ne - ni - no - nu - não

na - ne - ni - no - nu - não

a q u b A C S Z m X N O P C G V

PINTE A LETRA **N** e **n** DAS PALAVRAS QUE ESTÃO ESCRITAS NO DESENHO DA PENA.

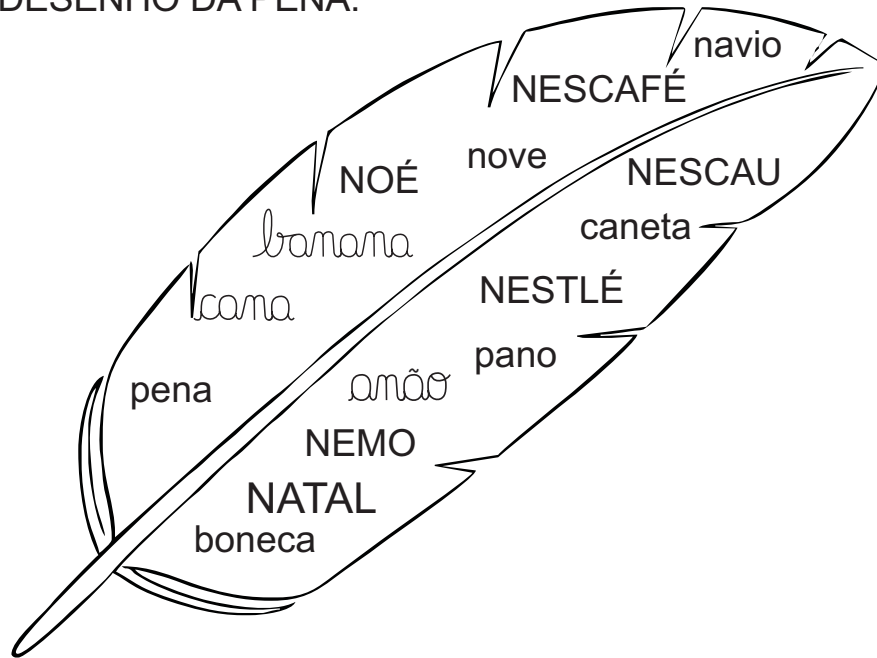

DESCUBRA O SEGREDO E COMPLETE.

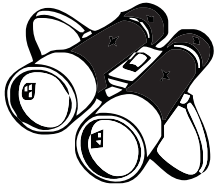

BINÓCULO					

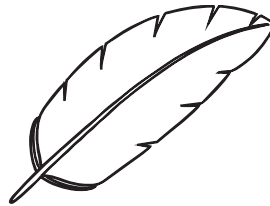

PENA					

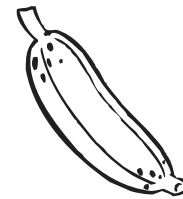

BANANA					



CONE					

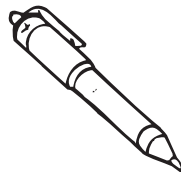

CANETA					

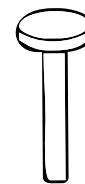

PINO					

C b v H a B q A C u z m O X

LEIA AS PALAVRAS DO QUADRO E COPIE DE ACORDO COM O QUE SE PEDE ABAIXO.

NAVE	MENINO	PANELA	CONE
NUCA	NEVE	NUVEM	BANANA
NINHO	ANÃO	NOVO	NENÊ
CANA	CANUDO	PENICO	CANO
NA	NE	NI	
NO	NU	NÃO	

DESCUBRA O SEGREDO E CIRCULE AS PALAVRAS QUE PERTENCEM AO GRUPO.

NATA NABO BANANA NEVE	NÃO BONECA NEMO CANECA	PENICO MENINO PENA ANIMAL
	PANO NUA PINO NOME	NUCA NUVEM NUA BONÉ

COPIE AS PALAVRAS CIRCULADAS EM SEU CADERNO.

a q u b A C S Z m X N O P C G V

PINTE OS DESENHOS CUJAS PALAVRAS TÊM SÍLABAS DA FAMÍLIA DA LETRA **N**.

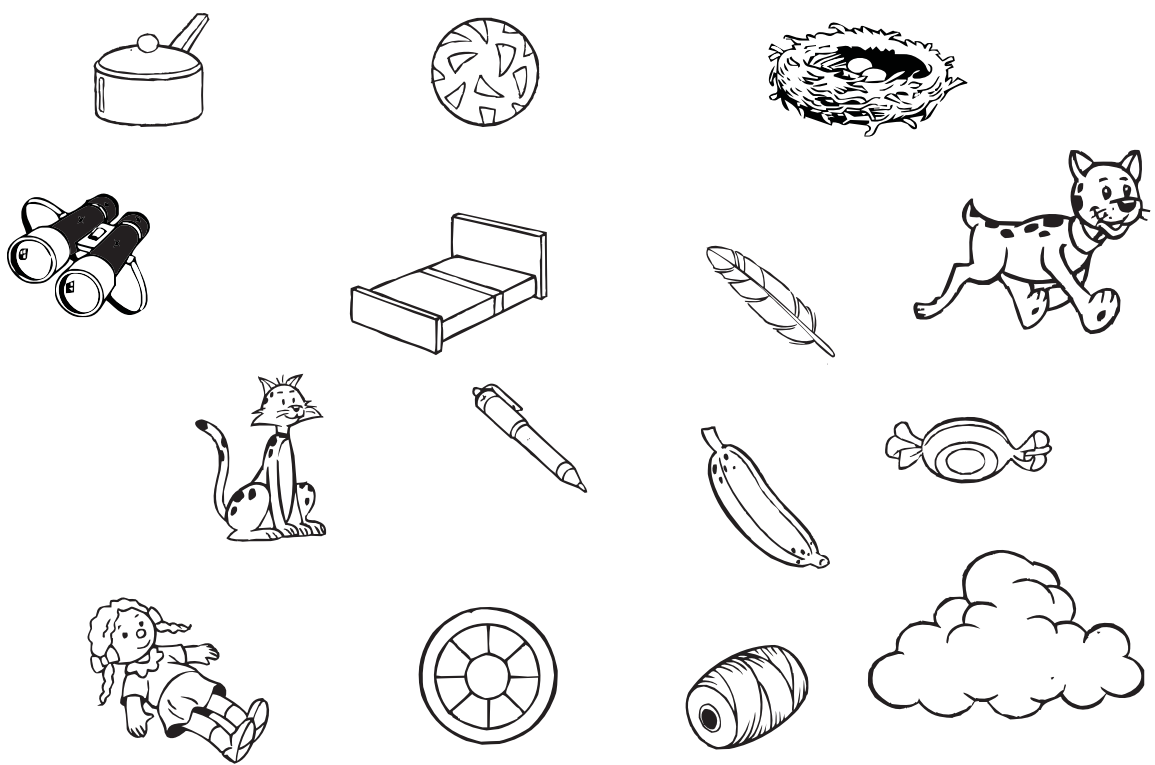

ESCREVA AS SÍLABAS QUE FALTAM NOS NOMES DOS DESENHOS.

BA _____ PA _____ LA CA _____

_____ NHO _____ VEM

_____ VELO CA _____ A ME _____

C b v h a B q A C u z m O X

LIGUE OS DESENHOS QUE COMEÇAM COM A MESMA SÍLABA.

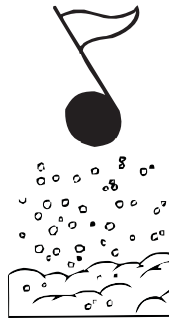
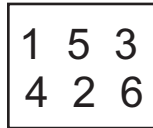
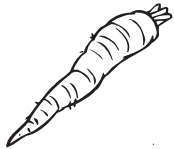
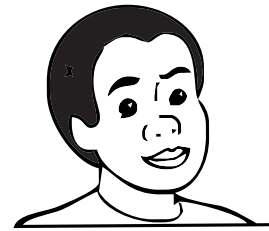
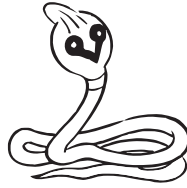

PINTE AS SÍLABAS QUE FORMAM OS NOMES DOS DESENHOS.

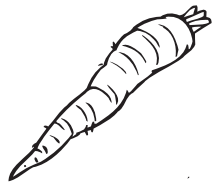

NE NA CA BO

NO NU VE LO

NI NO NA VE

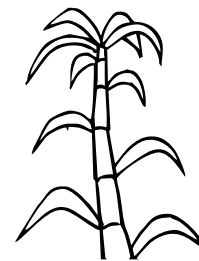

NE NA VI O

PE NE NA MA

BA CA NA LA

LIGUE OS DESENHOS ÀS PALAVRAS CORRESPONDENTES.

BONÉ



BONECA

BINÓCULO



CONE

ANÃO



NOVELO

BANANA



CANOA

PANELA



NUVEM

DESCUBRA AS PALAVRAS ESCONDIDAS NO QUADRO E COPIE.

1	2	3
BI	BA	NE
4	5	6
BO	NÓ	VO
7	8	9
NA	VE	CU
10	11	12
CA	LO	NO

1 - 5 - 9 - 11

12 - 8 - 11

12 - 6

4 - 3 - 10

3 - 8

4 - 3

12 - 8

2 - 7 - 7

11 - 7

1 - 7

NUMERE OS DESENHOS DE ACORDO COM AS PALAVRAS.

- 1 - PANO
- 2 - CANA
- 3 - BONECA
- 4 - NINHO
- 5 - PANELA
- 6 - CONE
- 7 - BONÉ
- 8 - BINÓCULO
- 9 - NUVEM
- 10 - CANUDO

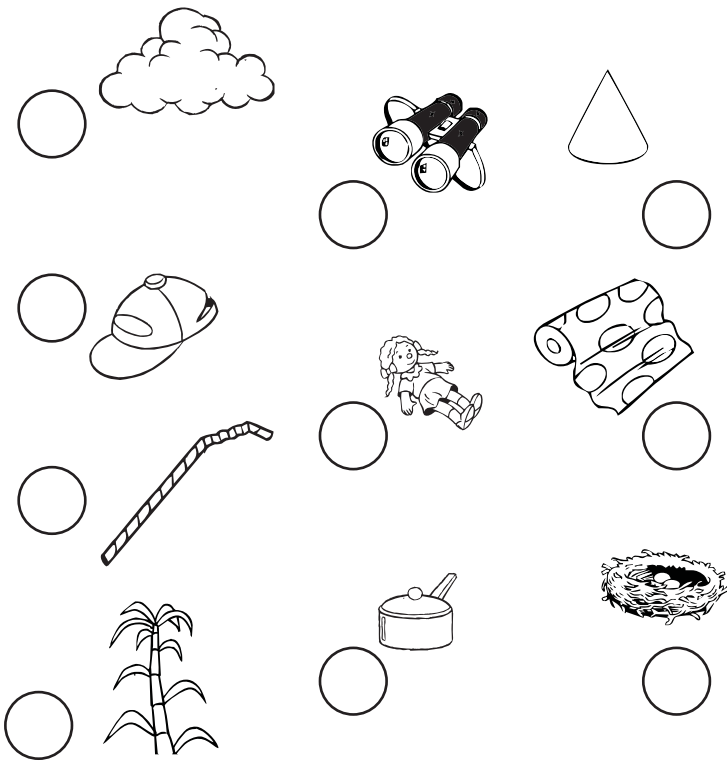

COMPLETE AS FRASES ESCRIVENDO AS PALAVRAS DO QUADRO, NO LUGAR ADEQUADO.

BANANA - BONÉ - BINÓCULO - BONECA - CANETA

EU DEI UMA _____ NOVA PARA O PAPAÍ.

PAULO PERDEU O _____ COLORIDO.

ANITA GANHOU UMA _____ BARBIE.

A VOVÓ ANA FEZ DOCE DE _____.

O _____ DO MENINO CAIU NO CHÃO.

ORDENE AS PALAVRAS FORMANDO FRASES.

BANANA. 5	GOSTA 3	O 1	DE 4	MACACO 2
--------------	------------	--------	---------	-------------

O 3	DO 5	VIU 2	FILME 4	NOÉ 1	NEMO. 6
--------	---------	----------	------------	----------	------------

BANANA 3	MAMÃE 1	FEIRA. 6	COMPROU 2	NANICA 4	NA 5
-------------	------------	-------------	--------------	-------------	---------

DE 5	É 2	ANA. 6	BARBIE 1	A 3	BONECA 4
---------	--------	-----------	-------------	--------	-------------

COPIE, DAS FRASES ACIMA, AS PALAVRAS QUE TÊM A LETRA **N**.

ESCREVA OS NOMES DOS DESENHOS E SEPRE AS PALAVRAS EM SÍLABAS.













a q u b A C S z m X N O p c g V
p
c
c
v
o
g
s
a
s
u
D
q
N
G
C
h
C b v h a B q A C u z m O X

ESCREVA AS PALAVRAS SEPARANDO-AS EM SÍLABAS, DE ACORDO COM OS NOMES DOS DESENHOS.

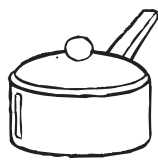

--	--	--



--	--	--

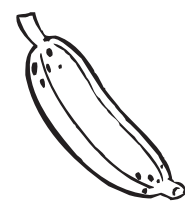

--	--	--



--	--



--	--

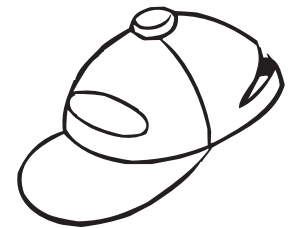

--	--

LEIA AS PALAVRAS E FORME OUTRAS INICIADAS COM AS SÍLABAS CIRCULADAS EM CADA FICHA.

CA(NA)

(NU)VEM

(NO)VELO

BI(NÓ)CULO

BA(NANA)

CA(NE)TA

PE(NA)





(NO)ME

LEIA AS PALAVRAS DO QUADRO E DEPOIS COPIE SEPARANDO-AS DE ACORDO COM O NÚMERO DE SÍLABAS.

NOVELO	LIMONADA	BONECA	MENINADA
BANANADA	CANELA	PENA	BANANA
NUCA	BONÉ	BINÓCULO	NABO

2 sílabas	3 sílabas	4 sílabas
_____	_____	_____
_____	_____	_____
_____	_____	_____
_____	_____	_____

PINTE AS FICHAS DAS PALAVRAS QUE CORRESPONDEM AOS DESENHOS.

	CANO	PIANO	ABANO	PANO
	ÓCULOS	CANELA	NUA	BINÓCULO
	BONECA	BANANA	NABO	PENA
	NOTA	NOME	NOVE	NOVELO
	NUCA	NUVEM	NUA	NAVE

CAÇA – PALAVRAS

PINTE CADA PALAVRA ENCONTRADA DE UMA COR.
PINTE-A TAMBÉM NO BANCO DE PALAVRAS

X	K	M	N	Ó	S	V	I	P
Z	A	N	O	V	E	L	O	A
C	B	J	K	T	U	C	P	N
I	I	N	O	T	A	A	N	E
B	N	L	V	R	W	N	U	L
O	Ó	C	N	U	C	A	V	A
N	C	A	X	S	U	N	E	X
E	U	N	Z	Z	Y	O	M	A
C	L	O	W	G	L	M	F	Q
A	O	N	O	V	E	E	O	M

NOME	BINÓCULO	NOTA
NOVE	NUCA	NOVELO
NÓ	NUVEM	CANA
CANO	BONECA	PANELA

a q u b A C S Z m X N O p c G V

AUTODITADO

É HORA DE ESCREVER PALAVRAS QUE TENHAM
SÍLABAS FORMADAS COM A LETRA **N - n**.

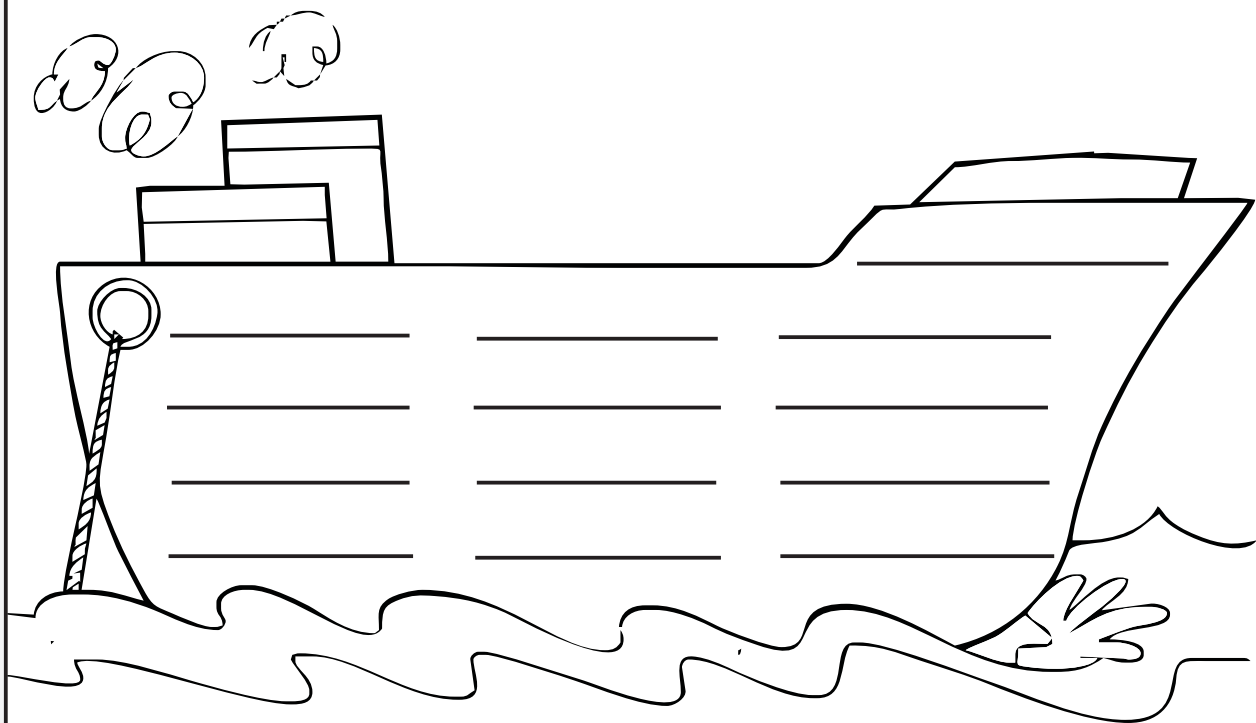

C b v H a B q A C u z m O X

a q u b A C S z m X N O p c G V

DITADO

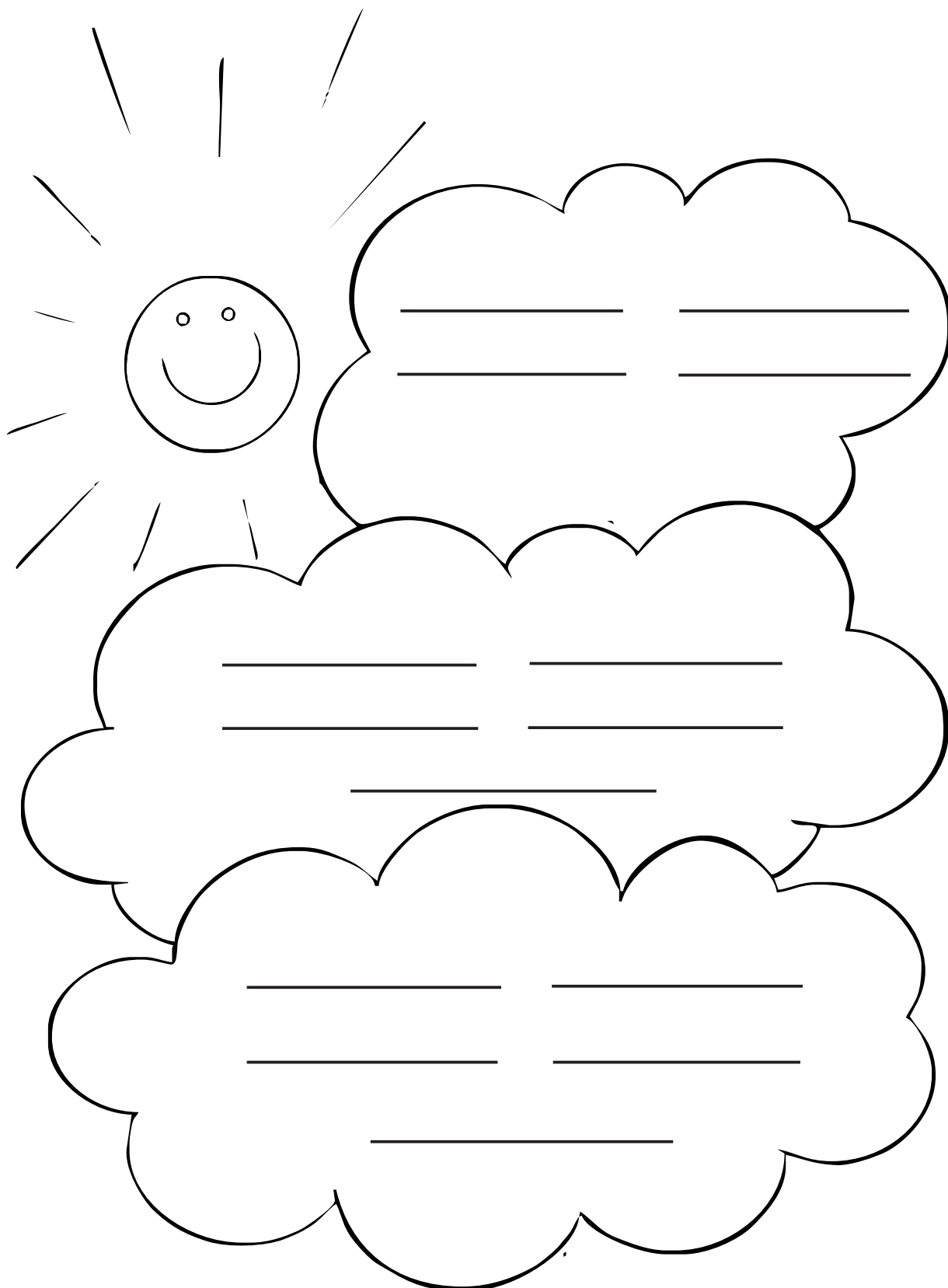

C b v H a B q A C u z m O X

a q u b A C S z m X N O p c g V

p

C

u

V

O

g

S

a

S

U

D

q

N

G

C

h

V

g

a

S

U

q

h

N

S

P

r

D

A

m

O

V

N

PIRULITO QUE BATE, BATE

PIRULITO QUE BATE, BATE,
PIRULITO QUE JÁ BATEU.
QUEM GOSTA DE MIM É ELA
QUEM GOSTA DELA SOU EU.

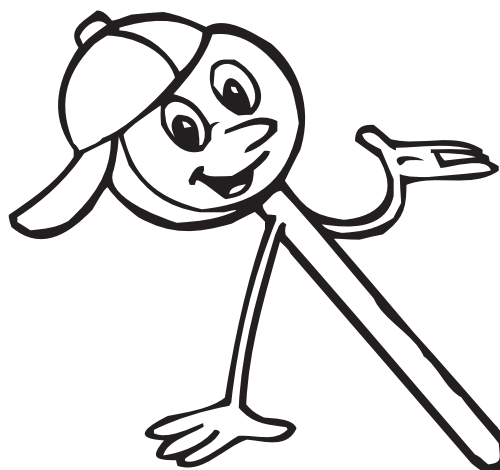

PIRULITO QUE BATE, BATE,
PIRULITO QUE JÁ BATEU.
A MENINA QUE EU AMAVA
ESTÁ BONITA E JÁ CRESCER.

(CD As mais Belas Cantigas de Roda. Ed. Ciranda Cultural, pág. 13)

PINTE NO TEXTO A PALAVRA PIRULITO.

COPIE.

pirulito

pirulito

A PALAVRA PIRULITO COMEÇA COM P.

p -

P -

p -

P -

C b v h a B q A C u z m O X

P	p
p	p



JUNTE A LETRA **P - p** COM AS VOGAIS E
FORME A FAMÍLIA SILÁBICA.

+	A	E	I	O	U
P					

PA - PE - PI - PO - PU

pa - pe - pi - po - pu

+	a	e	i	o	u	ão
p						

pa - pe - pi - po - pu - pão

pa - pe - pi - po - pu - pão

LEIA AS PALAVRAS E DEPOIS COPIE
SEPARANDO COMO SE PEDE.

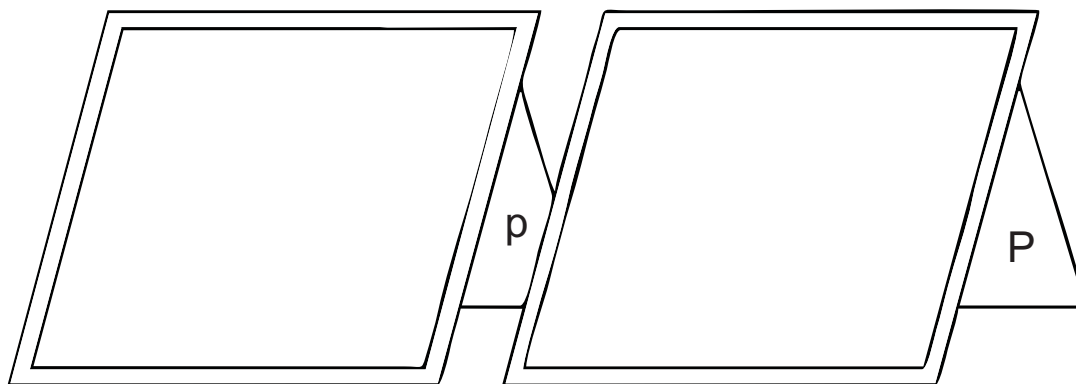
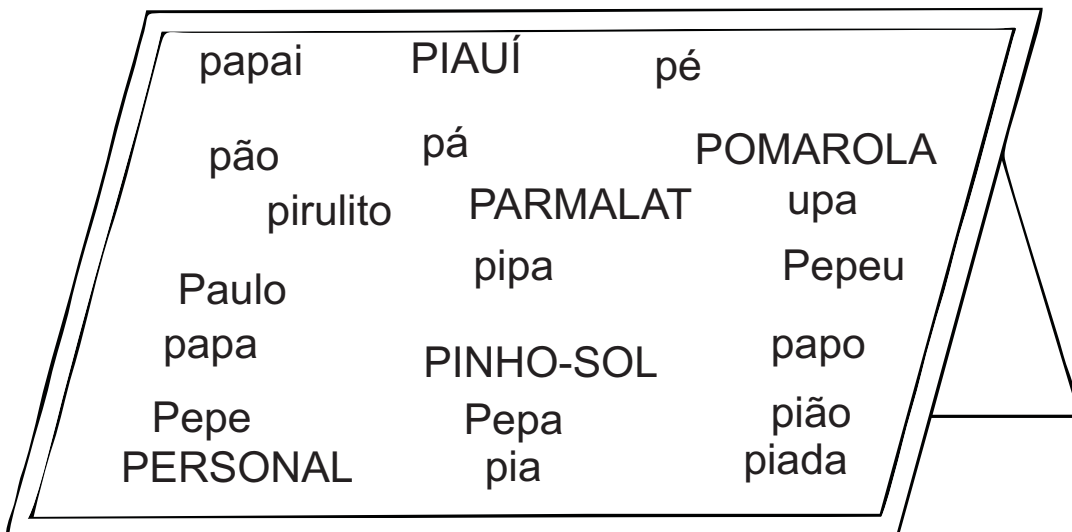

ESCREVA OS NOMES DOS DESENHOS.

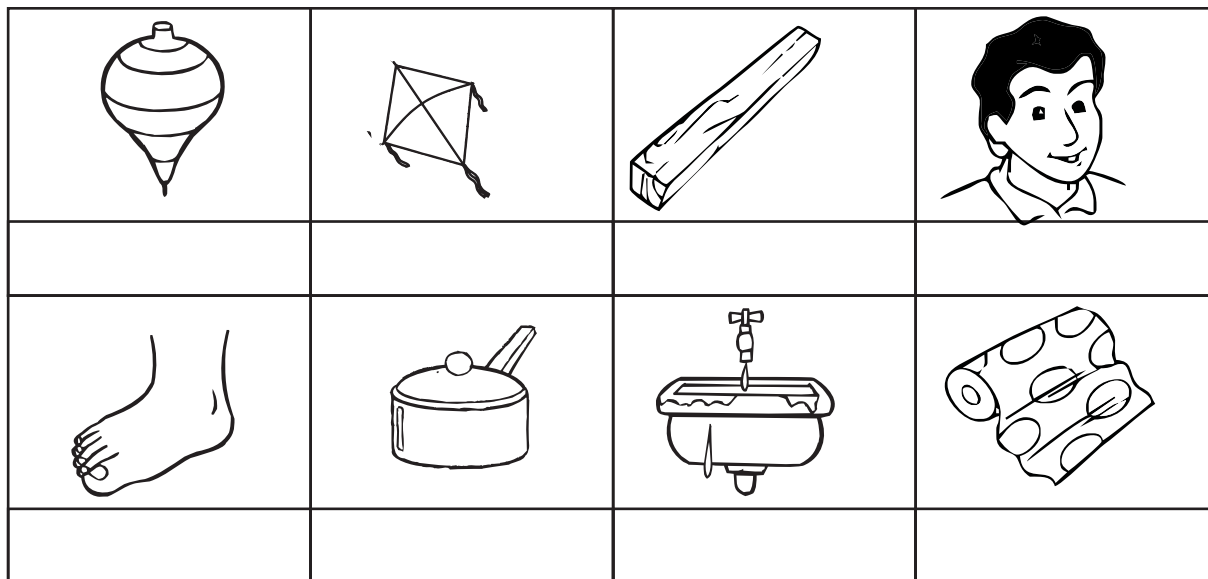

a q u b A C S Z m X N O P C G V

JUNTE AS SÍLABAS COM SÍMBOLOS IGUAIS E FORME PALAVRAS

● PA	♥ U	■ PA	☾ PI	■ PO	● PAI	◐ PE	◑ PA	☾ ãO	♥ PA
------	-----	------	------	------	-------	------	------	------	------

● _____	☾ _____	♥ _____
■ _____	◐ _____	◑ _____
●● _____	☾ _____	

LIGUE OS DESENHOS AOS NOMES E SEPRE AS SÍLABAS DAS PALAVRAS.

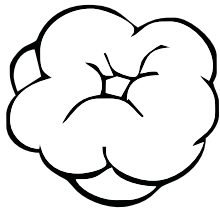
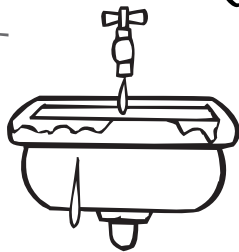
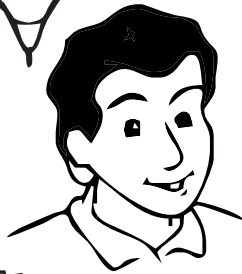
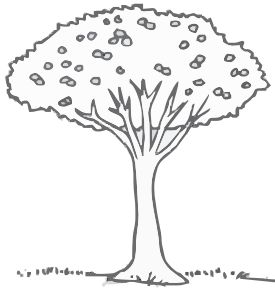
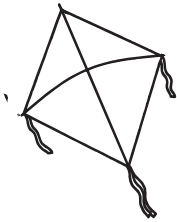

PIA

IPÊ

PAPAI

PANELA

PIPOCA

PIPA

PIÃO

PENA

C b v H a B q A C u z m O X

COPIE AS PALAVRAS DA CANTIGA
CONFORME O NÚMERO DE SÍLABAS.

PIRULITO	EU	AMAVA	COITADINHA
BATE	MENINA	QUEM	DELA

1 SÍLABA	2 SÍLABAS	3 SÍLABAS	4 SÍLABAS

ENCONTRE, NO CAÇA-PALAVRAS, O
VERSO "PIRULITO QUE BATE, BATE".

C	E	G	H	J	K	M	P	R	O
A	P	I	R	U	L	I	T	O	S
Q	U	E	X	L	Z	B	A	T	E
B	O	F	I	B	A	T	E	N	Q

LEIA AS SÍLABAS QUE ESTÃO NAS PIPOCAS E PINTE
NA MESMA COR AQUELAS QUE FORMAM PALAVRAS.
DEPOIS, LIGUE-AS AOS DESENHOS.

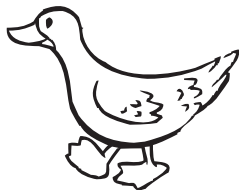
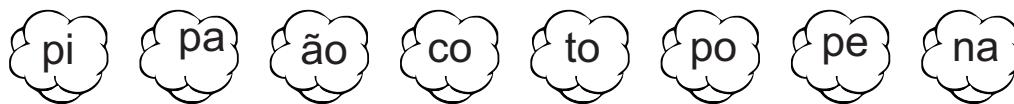

ADIVINHE.

TEM A VOZ FINA, CANTA A NOITE INTEIRA E NÃO DEIXA NINGUÉM DORMIR?

(PERNILONGO)

LIGUE AS SETAS E ESCREVA AS PALAVRAS FORMADAS.

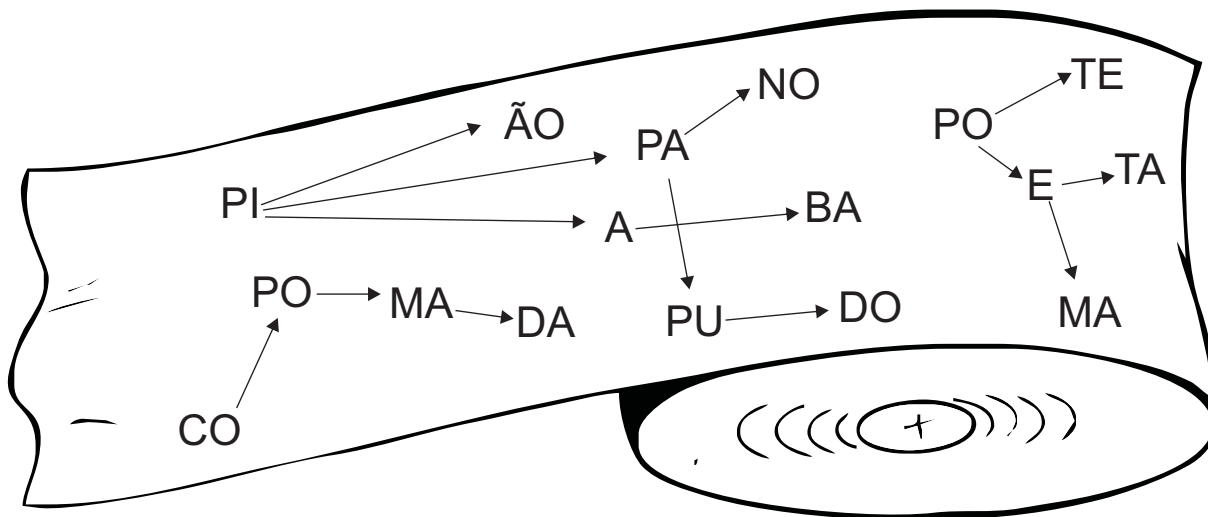

NUMERE OS DESENHOS DE ACORDO COM OS NOMES.

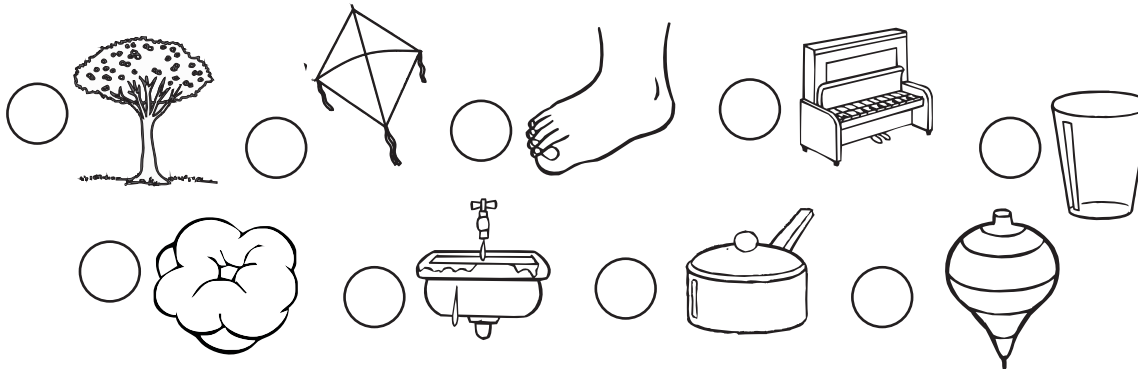

- | | | | | | |
|---|--------|---|--------|---|------|
| 1 | PÉ | 4 | PIPOCA | 7 | PIA |
| 2 | PIÃO | 5 | PIANO | 8 | COPO |
| 3 | PANELA | 6 | IPÊ | 9 | PIPA |

ADIVINHE.
QUANTO MAIS QUENTE ELE ESTÁ, MAIS FRESCO O DANADO É? (PÃO)

a q u b A C S Z m X N O P C G V
p c u l o g a s u q h z s p r D A m o v p n
ç h C b v H a B q A C u z m O X

JUNTE AS SÍLABAS QUE ESTÃO ESCRITAS
NAS PIPOCAS E FORME PALAVRAS.

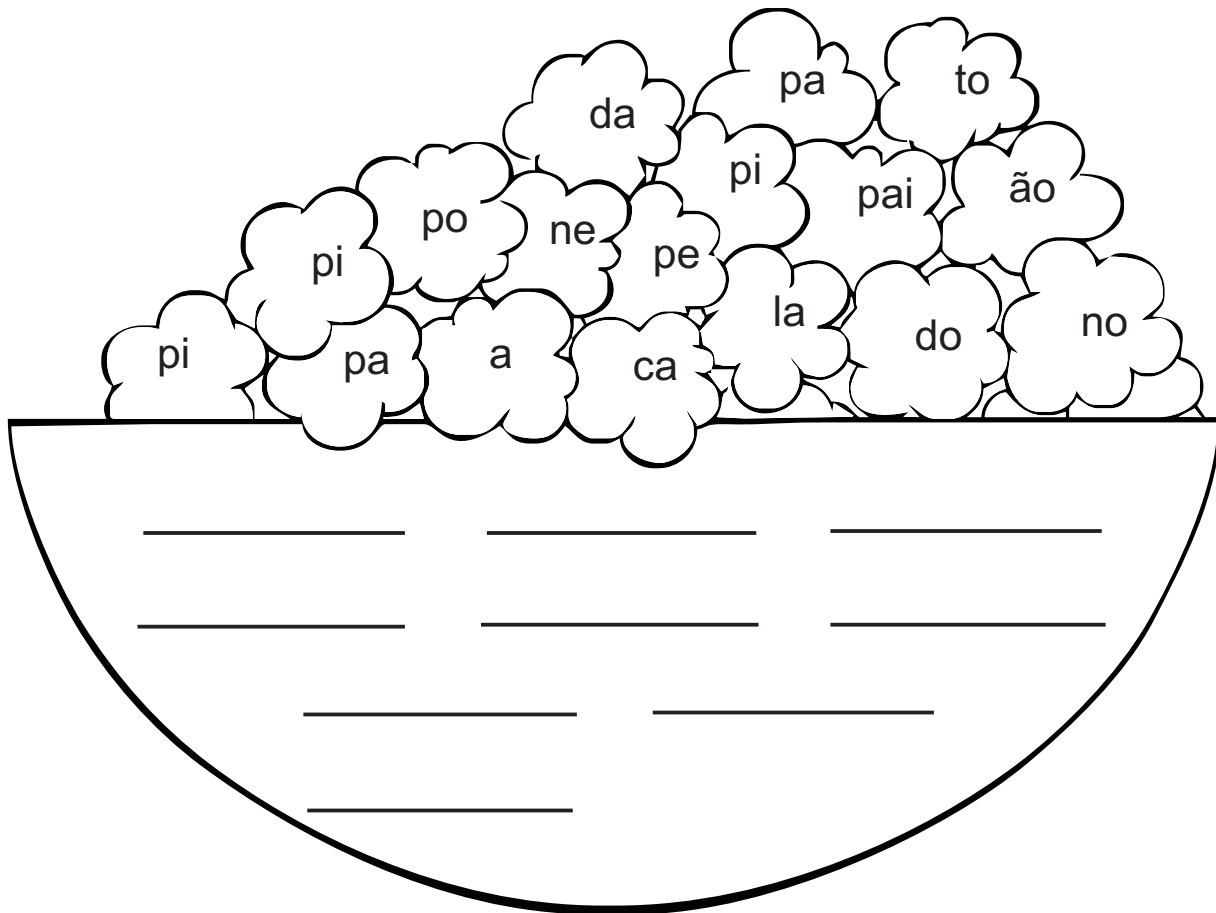

LIGUE AS PALAVRAS AOS DESENHOS.

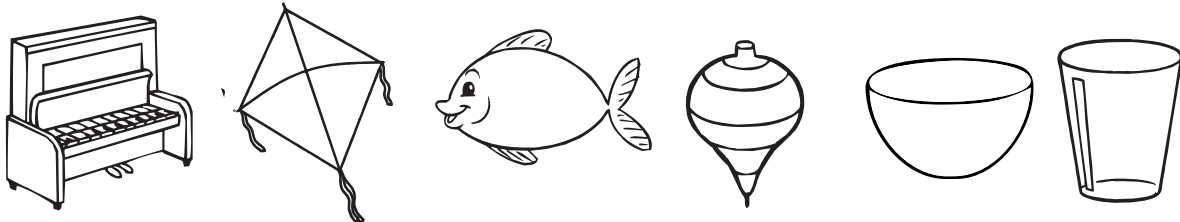

PIANO PIPA PIÃO POTE COPO PEIXE

ADIVINHE.
PULA NO AR, DÁ UM ESTOURO E VIRA NO AVESSE?

(PIPOCA)

ORDENE AS SÍLABAS E ESCREVA AS PALAVRAS DE ACORDO COM OS DESENHOS.

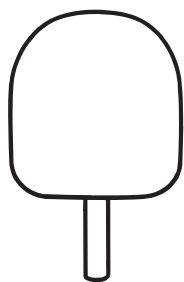

CO | PI | LÉ



PA | TO | SA

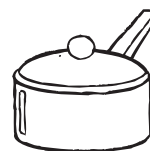

PA | LA | NE



LE | PA | TÓ



CA | TE | PE

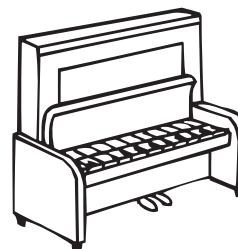

A | PI | NO

PINTE AS PALAVRAS QUE FAZEM PARTE DO GRUPO.

PATO PELADO PAPAI PALETÓ	PIPA PIPOCA PIÃO SAPATO	POMADA PILÃO POEIRA POTE	PAPUDO PÊLO PECADO PENA
-----------------------------------	----------------------------------	-----------------------------------	----------------------------------

COPIE NAS FICHAS AS PALAVRAS QUE VOCÊ NÃO PINTOU E SEPRE-AS EM SÍLABAS.

ESCREVA O NOME DOS DESENHOS E COMPLETE AS FRASES ABAIXO COM AS PALAVRAS CORRESPONDENTES.

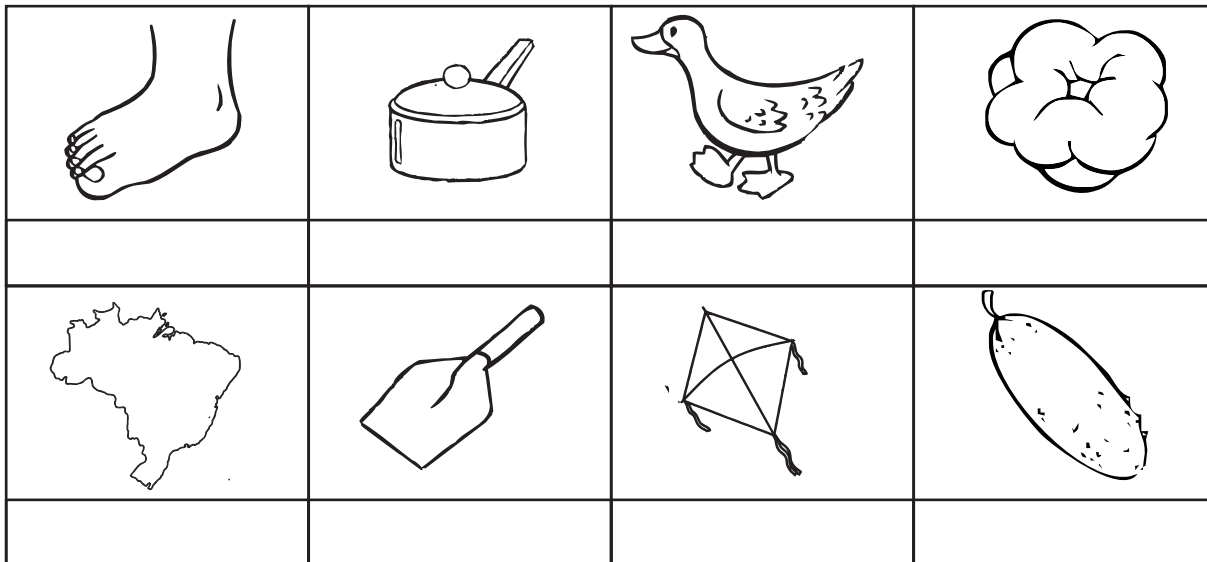

MAMÃE FEZ SALADA DE _____ COM TOMATE.

NA _____ TEM FEIJÃO COZIDO.

PAULO MACHUCOU O DEDÃO DO _____.

A _____ DO PEDREIRO QUEBROU O CABO.

PAPAI FEZ UMA _____ PARA O MENINO.

A _____ PULOU DA PANELA.

O _____ COMEU TODO O MILHO E FICOU PAPUDO.

PAULA PINTOU O _____ DO BRASIL.

LIGUE FORMANDO AS PALAVRAS.

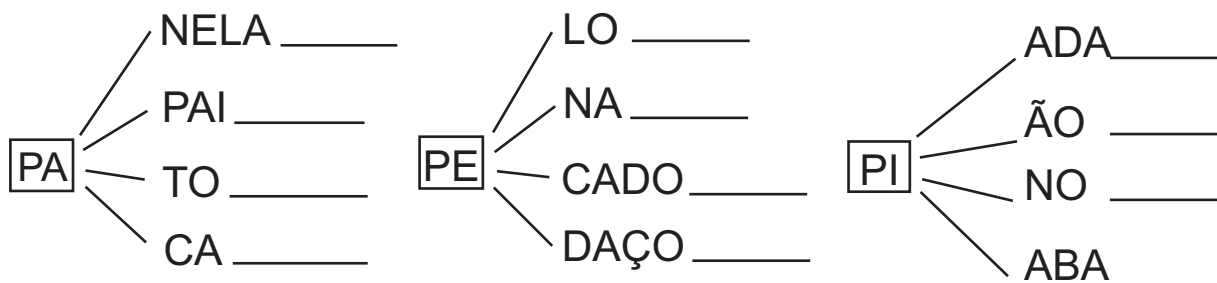

LEIA AS FRASES E FAÇA OS DESENHOS DAS PALAVRAS QUE TÊM A LETRA **P - p**.
COPIE AO LADO DOS DESENHOS AS PALAVRAS.

A PANELA COM PIPOCA ESTÁ NO FOGÃO.

--	--

O PAPAGAIO BICOU O PAPAI.

--	--

PEPEU JOGOU O PANO NA PIA.

--	--	--

FORME PALAVRAS E COMPLETE AS FRASES.

PA	PE	CA
GA	TO	PI
IO	PEU	PO

PEPE É O _____ QUE PEGOU O PÃO.

_____ JOGOU O PÃO NA ÁGUA.

O _____ É O POPÓ.

A _____ ESTÁ NA MATA.

NA PANELA TEM _____.

LEIA AS SÍLABAS DAS PLACAS. DEPOIS ESCREVA PALAVRAS QUE PODEM SER FORMADAS.

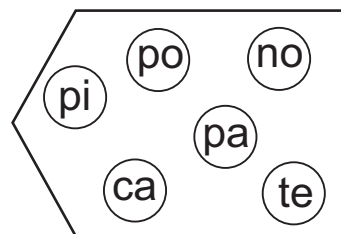
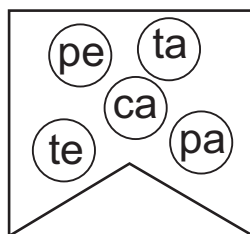
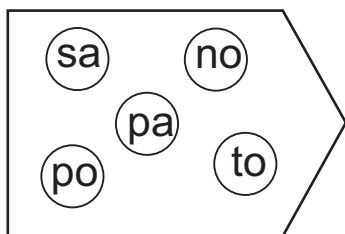

LEIA E ORDENE AS FRASES.

SAPATO PAPAI TIROU O NOVO.

NA ESTÁ PIPOCA A PANELA.

LIMÃO. TOMOU PEPE PICOLÉ DE

PALETÓ O PALHAÇO COLORIDO. TEM

PICOLÉ DO PALITO O CAIU.

ADIVINHE.

CAI DA TORRE, NÃO SE LASCA;
CAI NA ÁGUA, DESPEDAÇA.

(PAPEL)

(Coleção Atividades de Folclore. Ciranda Cultural).

CAÇA-PALAVRAS
 ENCONTRE NO CAÇA-PALAVRAS AS PALAVRAS DO
 QUADRO ABAIXO. PINTE CADA PALAVRA
 ENCONTRADA EM COR DIFERENTE.

A	Z	B	C	A	P	E	L	A	V
W	P	I	A	N	O	Z	M	X	Z
X	A	K	I	H	T	P	A	T	O
O	N	Q	G	N	E	A	K	Y	Q
A	E	T	J	Q	X	P	I	P	A
F	L	S	Z	P	I	Ã	O	I	W
P	A	P	A	I	R	O	T	C	J
U	D	Z	C	A	B	H	X	O	R
L	B	A	F	D	S	G	K	L	S
A	C	L	M	A	N	P	T	É	V

PIADA	PAPÃO	PAPAI	PIPA
CAPELA	PIANO	PATO	PANELA
POTE	PICOLÉ	PIÃO	PULA

SUBSTITUA OS DESENHOS DAS FRASES POR PALAVRAS.

O  NADA NA  .

MAMÃE FEZ  DOCE.

O  DO PAPAI É NOVO.

a q u b A C S z m X N O p c g v

LIGUE OS PONTOS E FORME O DESENHO. ESCREVA PALAVRAS QUE TENHAM AS SÍLABAS DA FAMÍLIA DA LETRA **P - p**.

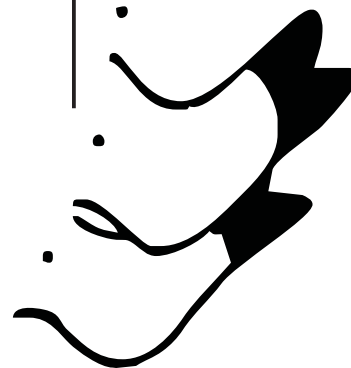
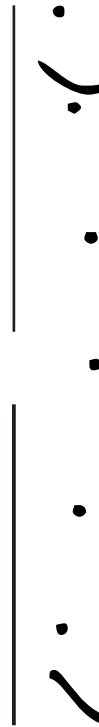
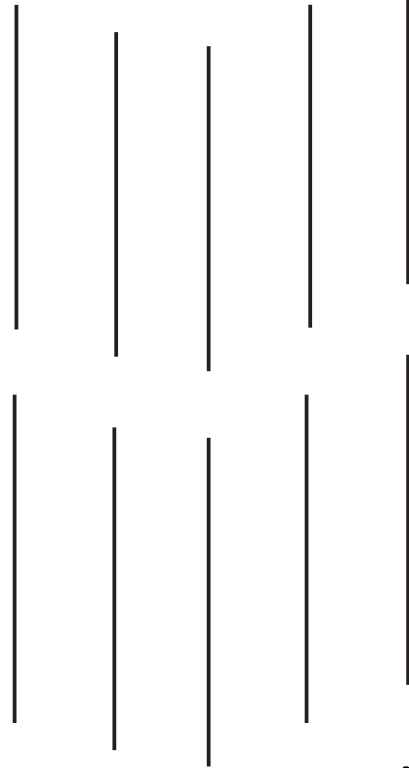
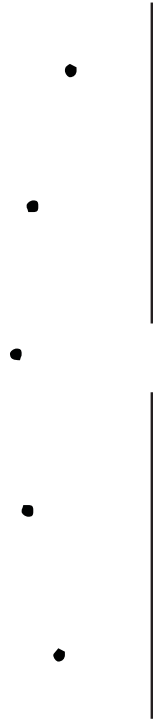
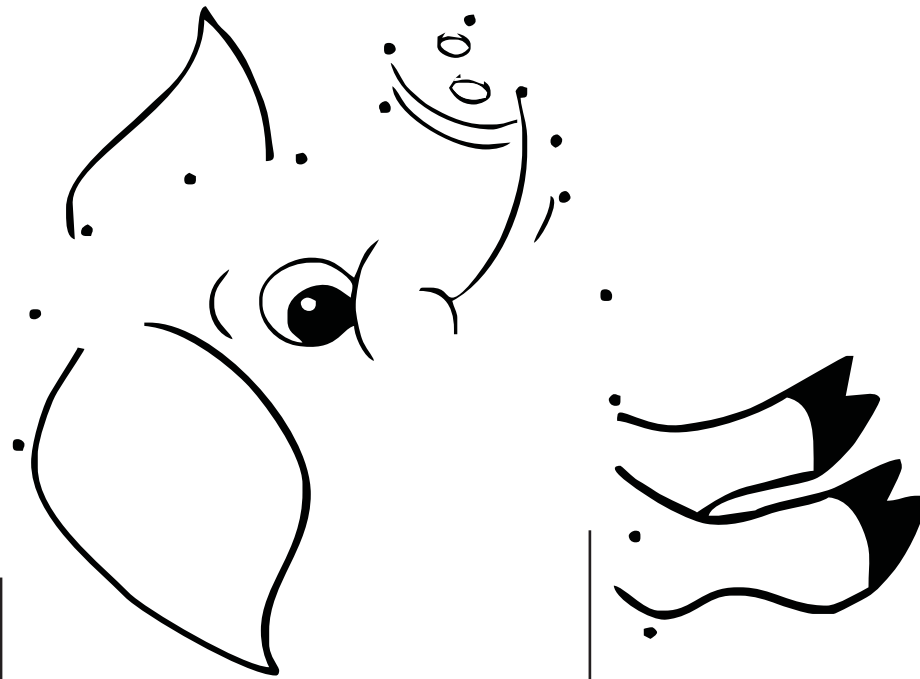

C b v H a B q A C u z m O X

a q u b A C S Z m X N O P C G V
p c v o g s a s u q h z s p r D A m O V P N
C b v H a B q A C u z m O X

DITADO

ESCREVA COM ATENÇÃO AS PALAVRAS DO DITADO.

1- _____
2- _____
3- _____
4- _____
5- _____
6- _____
7- _____
8- _____

9- _____
10- _____
11- _____
12- _____
13- _____
14- _____
15- _____
16- _____

a q u b A C S Z m X N O P C G V

TRAVA-LÍNGUA

O RATO ROEU A ROUPA DO REI DE ROMA.



ASSINALE, NO TRAVA-LÍNGUA, AS PALAVRAS QUE TÊM A LETRA **R**.

COPIE AS PALAVRAS.

rato - roeu - roupa - rei - **R**oma

rato - roeu - roupa - rei - **R**oma

rata - rolha - rainha

Roma rata rolha rainha

R-R -

r-r

C b v H a B q A C u z m O X

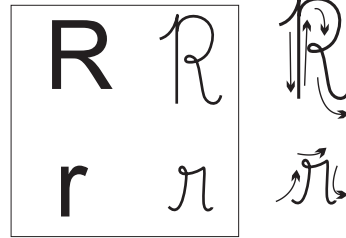
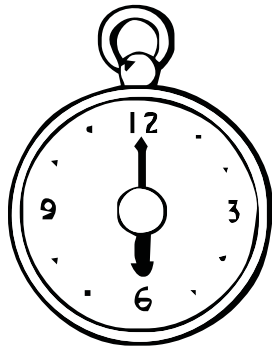

JUNTE A LETRA **R-r** COM AS VOGAIS E
FORME A FAMÍLIA SILÁBICA.

+	A	E	I	O	U
R					

COPIE.

RA - RE - RI - RO - RU

Ra - Re - Ri - Ro - Ru

+	a	e	i	o	u	ão
r						

ra - re - ri - ro - ru - rão

ra - re - ri - ro - ru - rão

LEIA AS PALAVRAS. DEPOIS, ESCREVA-AS NO QUADRO ADEQUADO DE ACORDO COM AS SÍLABAS.

<i>ru</i>	<i>ro</i>	régua	rifa	RONDÔNIA	
<i>roda</i>	ROMA	ramo	rico	relógio <i>rua</i>	
rato		remo	ralo	rádio	RECIFE
rosa	RITA	RUI	robô	RUTE	

	RA

	RE

	RI

	RO

	RU

ESCREVA AS SÍLABAS QUE FALTAM NOS NOMES DOS DESENHOS.

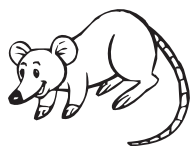

	TO
--	----

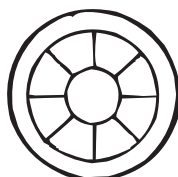

	DA
--	----

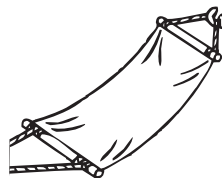

	DE
--	----



	SA
--	----

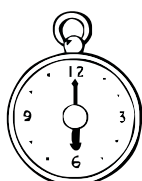

	LÓ	GI	O
--	----	----	---

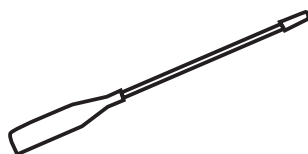

	MO
--	----



	LO
--	----

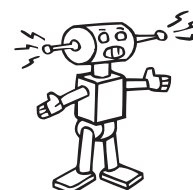

	BÔ
--	----

NUMERE OS DESENHOS DE ACORDO COM AS PALAVRAS.

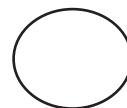
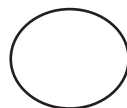
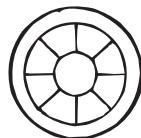
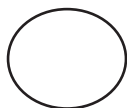
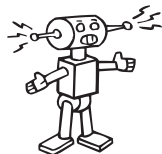
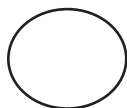
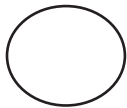
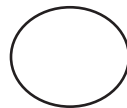
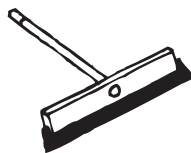
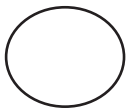
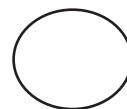
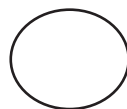
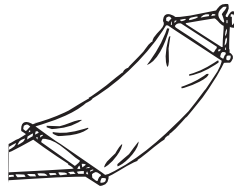
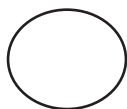
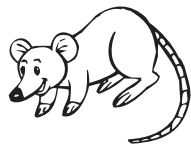
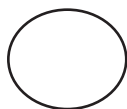

1-REI	4-RODA	7-RÃ	10-REDE
2-RALO	5-RIO	8-RODO	11-ROBÔ
3-RATO	6-RELÓGIO	9-RAMO	12-REMO

DESCUBRA O SEGREDO E ESCREVA AS PALAVRAS.

+	MO	TO	BO	LO
RA				
+	CA	FA	TA	PA
RI				
+	DE	MO	TO	LA
RE				

DESCUBRA AS PALAVRAS ESCONDIDAS NO ROBÔ.

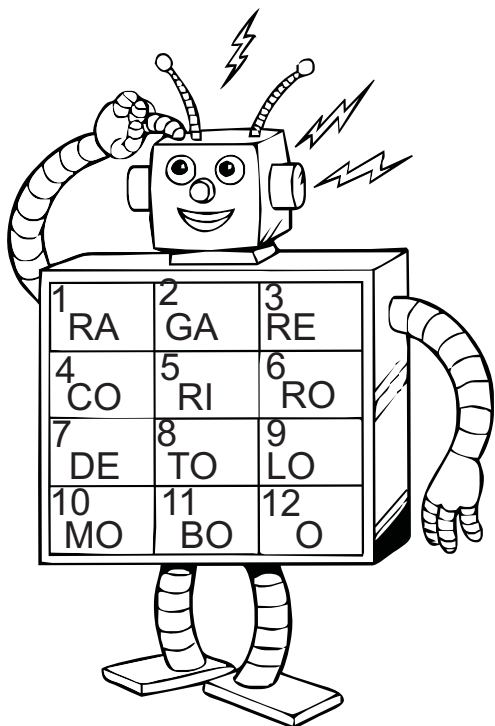

3 - 2

6 - 9

1 - 8

1 - 10

3 - 10

3 - 7

1 - 11

5 - 12

5 - 4

1 - 9

DESCUBRA O SEGREDO E COPIE AS PALAVRAS.

RA

ROMA

RE

RUTE

RI

REGINA

RO

RITA

RU

RAQUEL

SEPRE AS SÍLABAS DAS PALAVRAS.

REDE

REMO

RECIBO

REGA

RATO

RICA

RODADO

RUA

PINTE AS SÍLABAS QUE ESTÃO ESCRITAS NAS FIGURAS QUE TÊM A MESMA FORMA, NA MESMA COR E ESCREVA AS PALAVRAS.

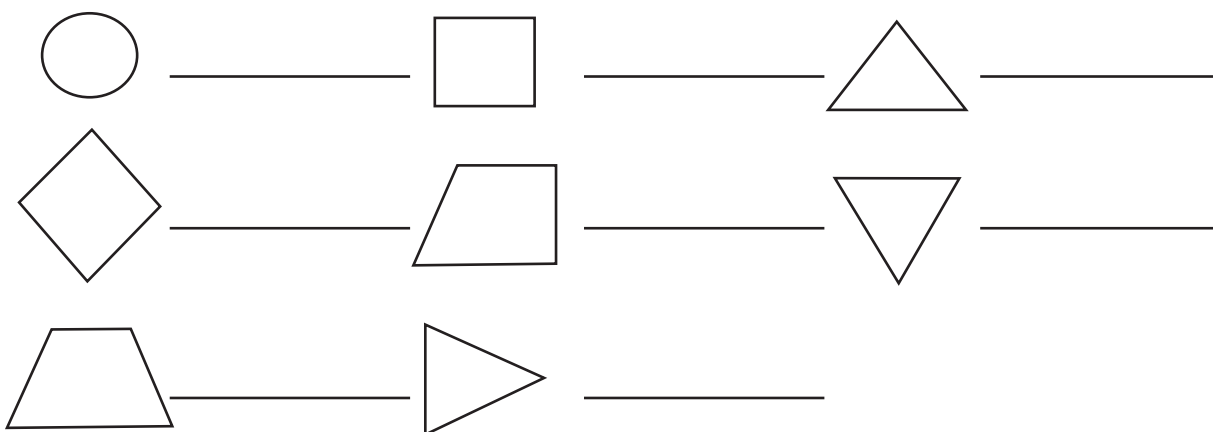
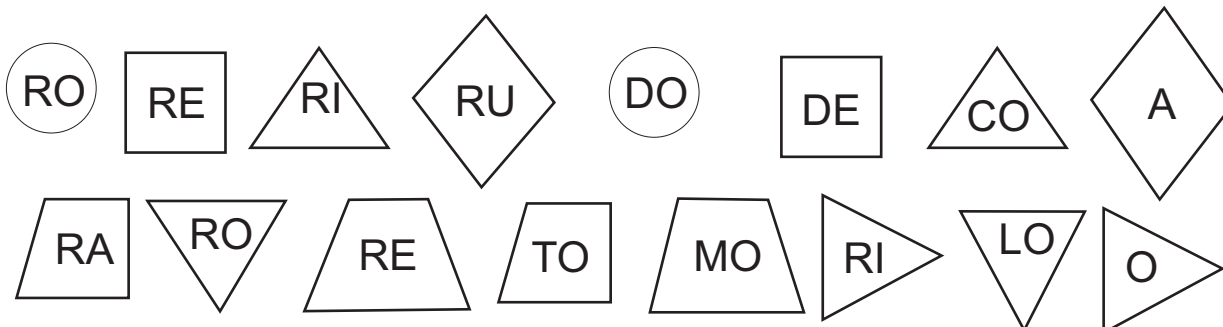

LIGUE AS SÍLABAS, ESCREVA AS PALAVRAS. DEPOIS, SEPRE-AS EM SÍLABAS.

RA
RE
RI
RO
RU

A
FA
DE
TO
DA

ESCREVA UMA FRASE COM AS PALAVRAS DAS FICHAS.

RÁDIO
RUA
RIO

COMPLETE COM UMA DAS SÍLABAS DO QUADRO E COPIE AS PALAVRAS FORMADAS.

___TO	RA
___MO	RE

___SO	RI
___DO	RO

___LO	RA
___TO	RE

RE	___A
RU	___DE

RI	___MO
RA	___FA

RO	___DE
RE	___DA

ESCREVA OS NOMES DOS DESENHOS.

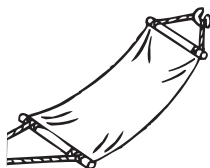





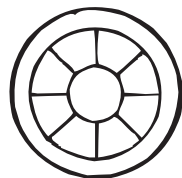



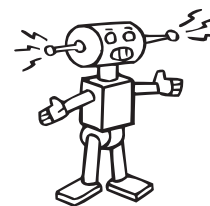







a q u b A C S Z m X N O P C G V

CIRCULE EM CADA QUADRO O NOME QUE CORRESPONDE AO DESENHO.

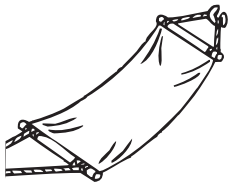

REDE REMO REI RELÓGIO

ROCA ROLA ROSA RODA

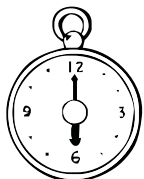
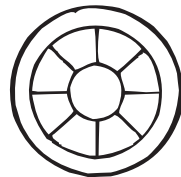

REI REMO RELÓGIO REDE

ROLO ROBÔ RODA ROMA

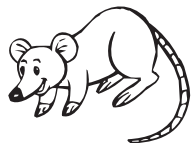
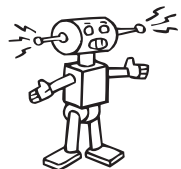

RÁDIO RAMO RALO RATO

ROTA ROLA ROMA RODO

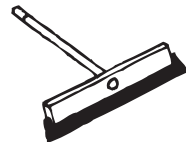

ESCREVA AS PALAVRAS QUE VOCÊ CIRCULOU E SEPRE-AS EM SÍLABAS.

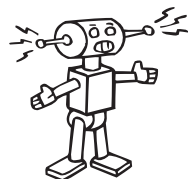
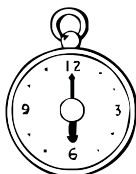
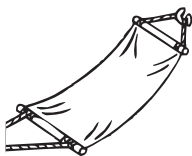

Blank box for writing the word 'REDE' in syllables.

Blank box for writing the word 'RELÓGIO' in syllables.

Blank box for writing the word 'ROBÔ' in syllables.

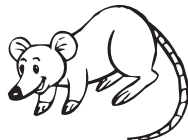

Blank box for writing the word 'RODA' in syllables.

Blank box for writing the word 'RATO' in syllables.

Blank box for writing the word 'RAMO' in syllables.

C b v h a B q A C u z m O X

a q u b A C S Z m X N O P C G V
 p c u v q h z s p r D A m O V P N
 S U D Q N G C h C b v H a B q A C U Z m O X

DOMINOX

ESCREVA AS PALAVRAS NO QUADRO.

- ROSA
- RIO
- REDE
- REMO
- ROLA
- REGA
- REI
- RELÓGIO

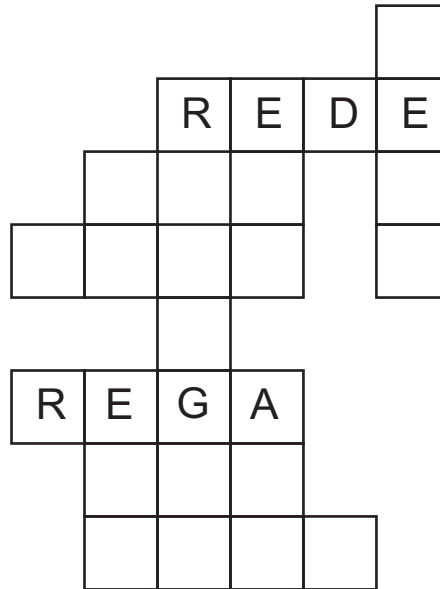

JUNTE AS SÍLABAS E FORME PALAVRAS.

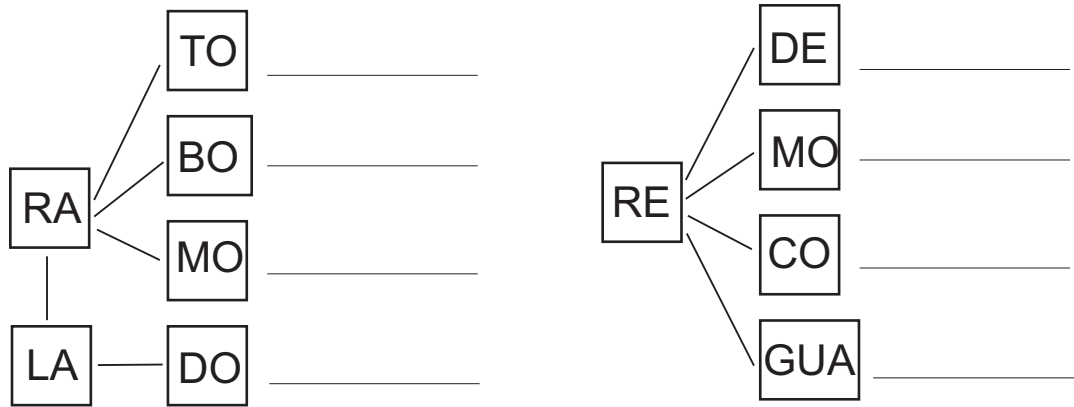

ORDENE AS SÍLABAS E ESCREVA AS PALAVRAS.

GI RE O LÓ

DO LA RA

DA RODA

RANHA I



MO RE

RANHO TI

COPIE AS FRASES SUBSTITUINDO OS DESENHOS POR PALAVRAS.

O  ROEU A  DO  DE ROMA.

PAPAI GANHOU UM  NOVO.

O  RIU MUITO DA ROUPA DA .

CIRCULE NO QUADRO AS SÍLABAS REFERENTES AOS DESENHOS E ESCREVA AS PALAVRAS.



RE MO
CO DE



TO RA
LO BO



MO I
RE DE
TO

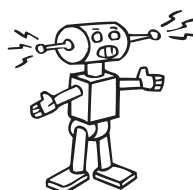

RO LO
DO DE
BÔ



MOCO
RA
DE TO

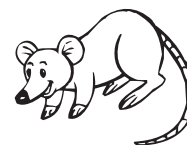

TO CO
GO LA
RA

ADIVINHE.

ANDA, ANDA, E VOLTA SEMPRE PARA O MESMO LUGAR?

(RELÓGIO)

CAÇA – PALAVRAS
 PINTE CADA PALAVRA ENCONTRADA
 EM COR DIFERENTE. PINTE-A,
 TAMBÉM, NO BANCO DE PALAVRAS.

C	F	H	K	N	P	R	A	B	O
R	Á	D	I	O	Q	O	S	R	Ã
E	B	R	E	M	O	B	U	I	V
L	D	I	G	L	T	Ô	W	F	X
Ó	J	C	A	D	F	H	Y	A	Z
G	B	O	R	O	D	O	J	L	A
I	R	U	A	R	E	I	R	I	O
O	A	C	L	O	K	P	U	V	Z
E	T	G	O	D	M	S	T	W	B
N	O	Q	X	A	Y	Z	E	K	I

RIO	RALO	REMO	RATO
RÁDIO	RIFA	RUA	RÃ
RODO	RELÓGIO	RICO	RUTE
REI	RABO	RODA	ROBÔ

a q u b A C S z m X N O p c G V

AUTODITADO

É HORA DE ESCREVER PALAVRAS QUE TENHAM SÍLABAS DA FAMÍLIA DA LETRA **R-r**.

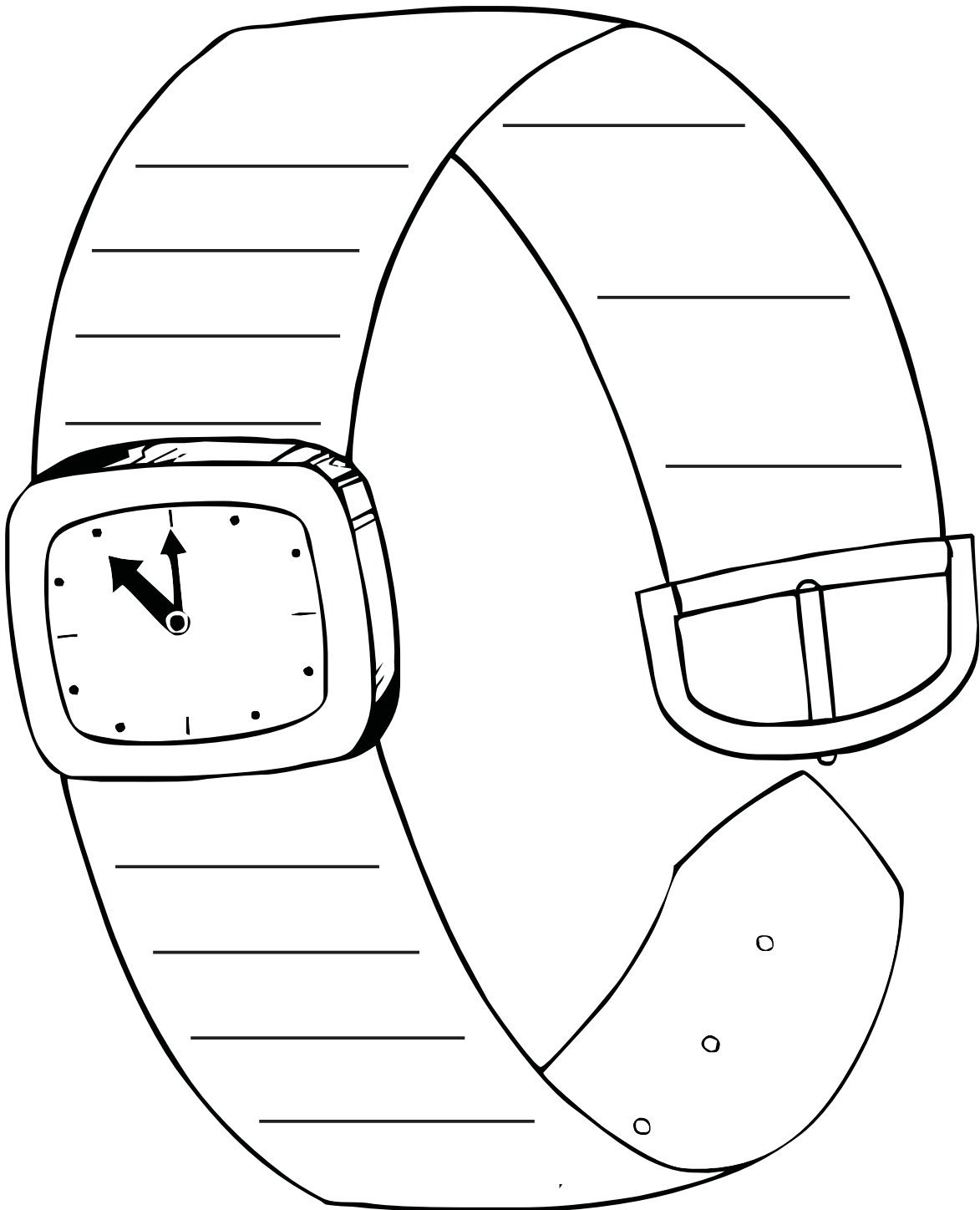

C b v H a B q A C u z m O X

a q u b A C S z m X N O p c G V

HORA DO DITADO

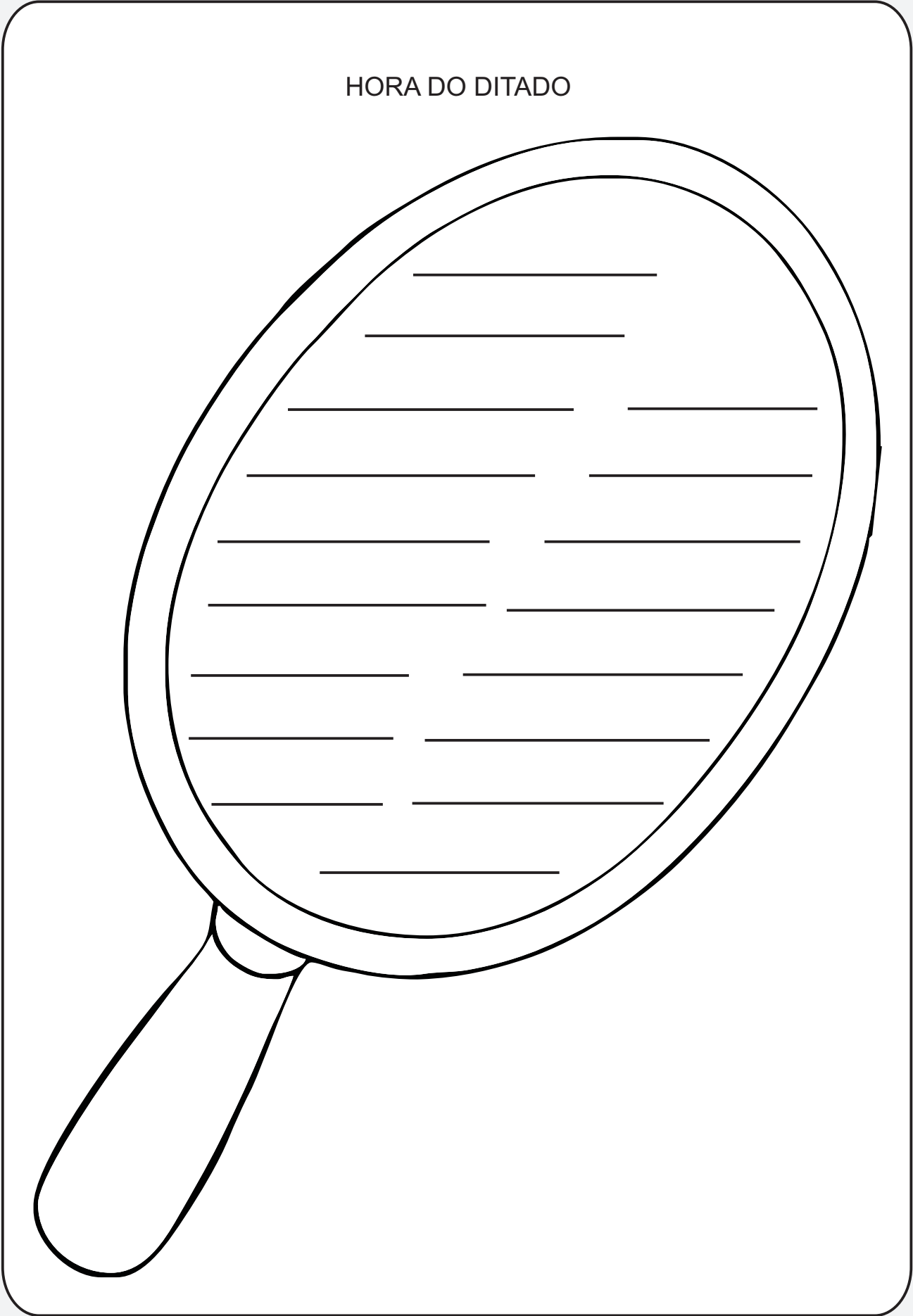

C b v H a B q A C u z m O X

SABIÁ

SABIÁ, LÁ NA GAIOLA,
FEZ UM BURQUINHO,
VOOU, VOOU, VOOU, VOOU,
E A MENINA QUE GOSTAVA TANTO DO BICHINHO.
CHOROU, CHOROU, CHOROU, CHOROU.

SABIÁ FUGIU PRO TERREIRO,
FOI CANTAR LÁ NO ABACATEIRO
E A MENINA VIVE A CHORAR
VEM CÁ, SABIÁ, VEM CÁ.

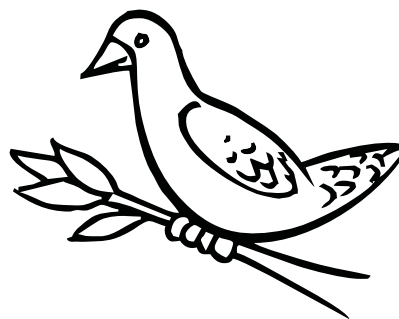

A MENINA DIZ, SOLUÇANDO,
SABIÁ ESTOU TE ESPERANDO.
SABIÁ RESPONDE A CANTAR:
NÃO CHORES QUE EU VOU VOLTAR.

(CD *Cantigas Infantis*. Ciranda Cultural, pág. 92)

CIRCULE NO TEXTO A PALAVRA SABIÁ.

COPIE A PALAVRA.

SABIÁ –

sabiá –

sabiá

COPIE A LETRA **S – s**.

S

S

s

s

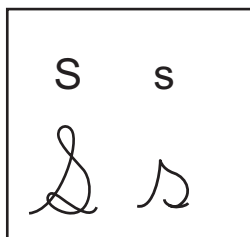

JUNTE A LETRA **S - s** COM AS VOGAIS
E FORME A FAMÍLIA SILÁBICA.

+	A	E	I	O	U
S					

COPIE.

SA - SE - SI - SO - SU

So - Se - Si - So - Su

+	a	e	i	o	u	ão
s						

sa	se	si	so	su	são

sa - se - si - so - su - são

a q u b A C S Z m X N O P C G V

PINTE A LETRA **S - s** NAS PALAVRAS DA SACOLA.

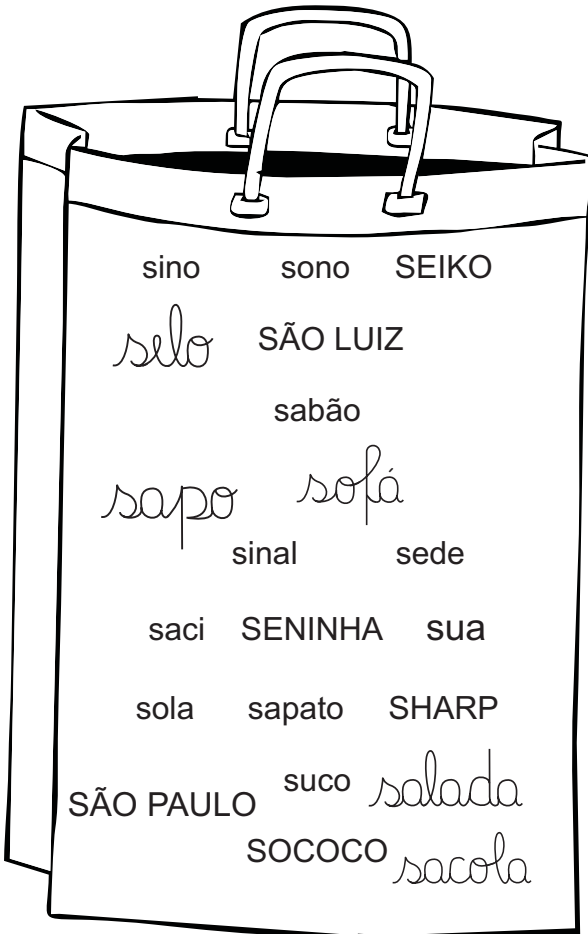

COPIE DO DESENHO DUAS PALAVRAS QUE TENHAM AS SÍLABAS.

SA	SE
SI	SÃO
SO	SU

PINTE SOMENTE OS DESENHOS QUE INICIAM COM AS SÍLABAS DA FAMÍLIA DA LETRA **S - s**.

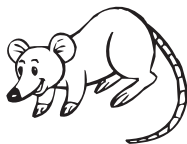
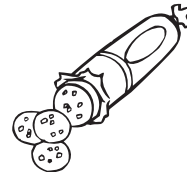
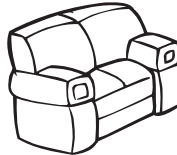
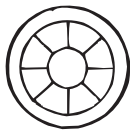

C b v H a B q A C u z m O X

SALADA, SALADINHA

SALADA, SALADINHA,
FEIJÃO COM PIMENTA,
NA HORA DA JANTA,
NÃO TEM QUEM AGUENTA!

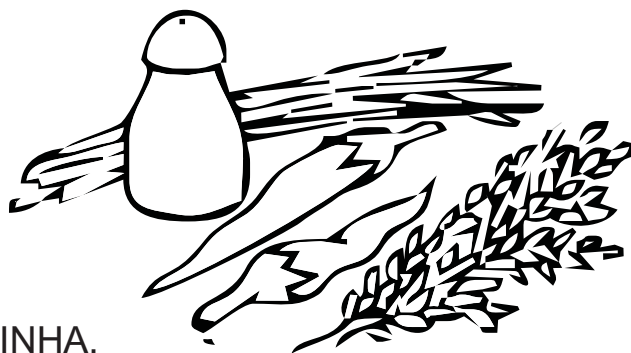

SALADA, SALADINHA,
BEM TEMPERADINHA,
SAL, PIMENTA, SALSA, CEBOLINHA,
É UM, É DOIS, E TRÊS!

Domínio Público

COPIE DO TEXTO AS PALAVRAS QUE TÊM A LETRA **S - s**.

SEPARA AS PALAVRAS EM LETRAS E SÍLABAS.

SALADA					

SALADINHA									

LIGUE E FORME PALAVRAS.

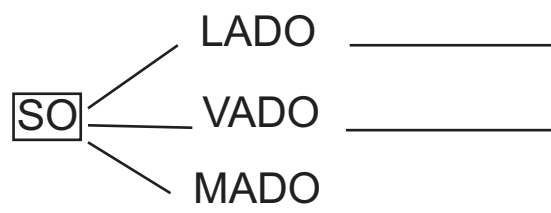

JUNTE AS SÍLABAS DOS QUADROS
E ESCREVA AS PALAVRAS.

+	LA	CA	PO	BÃO
SA				

+	CO	FÁ	LA	TÃO
SO				

+	CA	LO	TA	BO
SE				

+	A	MO	CO	JO
SU				

+	NO	FÃO	GA	GO
SI				

COMPLETE AS PALAVRAS COM
SÍLABAS DA FAMÍLIA DA LETRA **S - s**.

_____ LA	_____ NO	_____ FÁ
_____ PO	_____ CO	_____ BÃO
_____ RI	_____ TIÃ	_____ DE
_____ COLA	_____ NETA	_____ PATO
_____ BADO	_____ LAME	_____ ADO
_____ MANA	_____ CI	_____ PATADA

JUNTE AS SÍLABAS COM OS SÍMBOLOS IGUAIS E FORME PALAVRAS.

SI	SA	SI	PA	NO	NE	TA	TO
●	△	☆	△	●	☆	☆	△

● _____ △ _____ ☆ _____

SA	SAL	SA	PA	LA	TA	ME	DA	SA
◇	◆	☾	◇	☾	◇	☾	◇	◆

◇ _____ ☾ _____ ◆ _____

PINTE AS SÍLABAS QUE FORMAM OS NOMES DOS DESENHOS E ESCREVA AS PALAVRAS FORMADAS.



TA SA BA CO LA

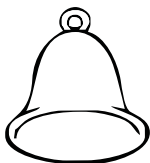

SA LA SI NO

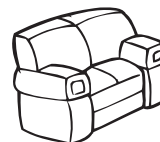

SO SA FÁ BA

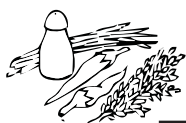

SA MA LA DA

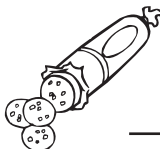

FA SA LA ME MI



SA CA PO TO



SA BA PA MA TO



BA SA TI CI



CA SE NO LO

LIGUE OS DESENHOS QUE COMEÇAM COM A MESMA SÍLABA.



LEIA AS PALAVRAS DAS FICHAS E FAÇA DESENHOS QUE REPRESENTA-OS.

SACOLA

SOFÁ

SALAME

SEMÁFORO

SAPO

SOPA

ESCREVA AS SÍLABAS QUE FALTAM NOS NOMES DOS DESENHOS.



	PO
--	----

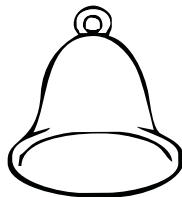

	NO
--	----



	MEN	TE
--	-----	----



	LO
--	----



	CO	LA
--	----	----



	PA	TO
--	----	----

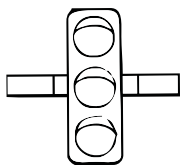

	MÁ	FO	RO
--	----	----	----



	CO
--	----

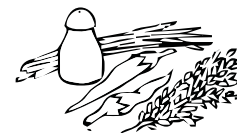

	LA	DA
--	----	----

LEIA AS PALAVRAS E SEPRE-AS EM LETRAS E EM SÍLABAS.

SINO			

SAPATO				

SELO			

SALADA				

SOFÁ			

SALAME				

SUBSTITUA OS NÚMEROS PELAS SÍLABAS
CORRESPONDENTES E FORME PALAVRAS.

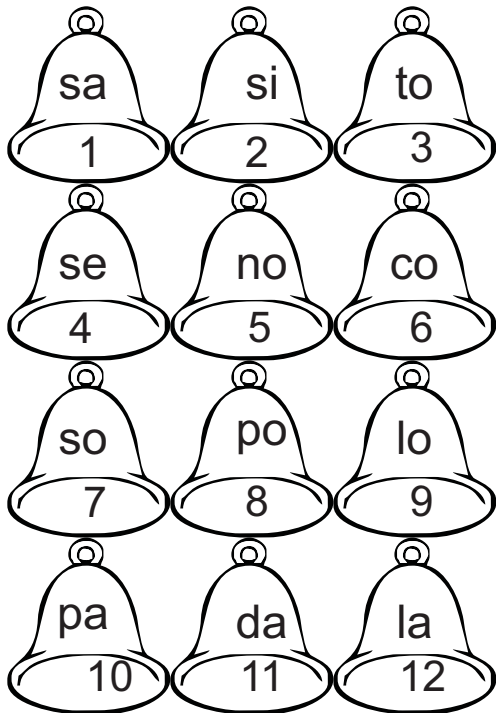

1 - 8

1 - 6 - 12

1 - 12

7 - 12

4 - 6

1 - 10 - 3

1 - 10

1 - 12 - 11

2 - 5

4 - 9

SEPARE AS PALAVRAS EM SÍLABAS
E LIGUE A ESCRITA AOS DESENHOS.

SACOLA
□ □ □

SINO
□ □

SAPATO
□ □ □

SALADA
□ □ □

SALAME
□ □ □

SOFÁ
□ □

SUTIÃ
□ □ □



SUCURI
□ □ □



LIGUE O DESENHO À PALAVRA
CORRESPONDENTE E ESCREVA O NOME.

 SECO SINAL SINO _____	 SOFÁ SALADA SAPATO _____	 SINO SACOLA SOFÁ _____
---	--	--

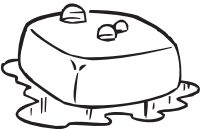
 SOFÁ SELO SAPO _____	 SAPATO SALADA SALAME _____	 SINO SALA SELO _____
--	--	--

 SALA SAPO SACO _____	 SABÃO SACI SOPA _____	 SABIÁ SALADA SALAME _____
--	---	---

LIGUE, FORME PALAVRAS E COPIE-AS.

SA	LA	_____
	PA	_____
BA	DO	_____

SI	NO	_____
	NAL	_____
	FÃO	_____
NE	TA	_____

SO	LA	_____
	CO	_____

SE	LO	_____
	CO	_____

COPIE AS FRASES SUBSTITUINDO OS DESENHOS POR PALAVRAS.

MAMÃE LAVOU A



COM



A



DE SOFIA CAIU NO

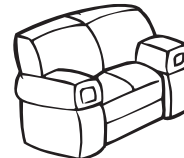

O



PULOU DENTRO DA



SIMÃO TOCOU O  DA IGREJA.

PINTE AS SÍLABAS FORMANDO PALAVRAS. PARA CADA PALAVRA USE UMA COR DIFERENTE. ESCREVA AS PALAVRAS FORMADAS AO LADO DO QUADRO.

SA	TA	SU	SE	SA
SI	PO	CO	SA	CO
SA	NO	SO	LO	LA
SA	LA	TO	CI	SO
SE	PA	DA	PA	FÁ

1-

7-

2-

8-

3-

9-

4-

10-

5-

11-

6-

12-

ESCOLHA UMA PALAVRA DAS FICHAS E COMPLETE AS FRASES.

SAPO - SINO - SALÃO - SUADO

O _____ DA IGREJA TOCOU LOGO CEDO.

SAPATO - SACOLA - SELO - SALADA

MAMÃE FEZ _____ DE TOMATE.

SALÃO - SECO - SAPO - SOPAPO

O _____ PULOU DA SACOLA.

SAPO - SINO - SECO - SAPATO

O SAPO PULOU DENTRO DO _____ DO PAPAI.

ORDENE AS PALAVRAS E ESCREVA AS FRASES.

PULA 3 O 1 PÉ 5 SACI 2 NUM 4 SÓ. 6

SACOLA.5 SAPATO 2 ESTÁ 3 O 1 NA 4

DE 3 TEM 5 SAIA 2 SOFIA 4 A 1 BABADO.6

ADIVINHE.
DA ÁGUA NASCE, NA ÁGUA CRESCE.
SE BOTAR NA ÁGUA, DESAPARECE.

(O SAL)

CAÇA – PALAVRAS

PINTE CADA PALAVRA ENCONTRADA EM COR DIFERENTE, PINTANDO-A TAMBÉM NO QUADRO DE PALAVRAS.

W	X	S	A	P	O	X	S	A	L
Z	Y	A	L	S	A	P	A	T	O
S	A	L	A	A	M	Z	I	Y	K
A	W	A	K	B	P	W	A	Z	X
L	A	M	N	I	R	X	P	Q	M
A	S	E	Q	Á	V	S	O	C	O
D	O	S	O	P	Ã	O	D	R	N
A	F	O	T	Ç	T	M	V	S	P
Ç	Á	L	W	Z	Y	A	K	U	Q
I	J	A	K	S	I	N	O	C	R
S	E	L	O	F	J	G	I	O	T

SAPO	SOMA	SAIA	SOLA
SOFÁ	SAL	SALAME	SUCO
SOPÃO	SALA	SINO	SABIÁ
SELO	SAPATO	SOCO	SALADA

a q u b A C S Z m X N O P C G V

AUTODITADO

ESCREVA PALAVRAS QUE TENHAM
SÍLABAS DA FAMÍLIA DA LETRA **S - s**.



C b v h A B q A C u z m O X

a q u b A C S Z m X N O P C G V

É HORA DO DITADO.

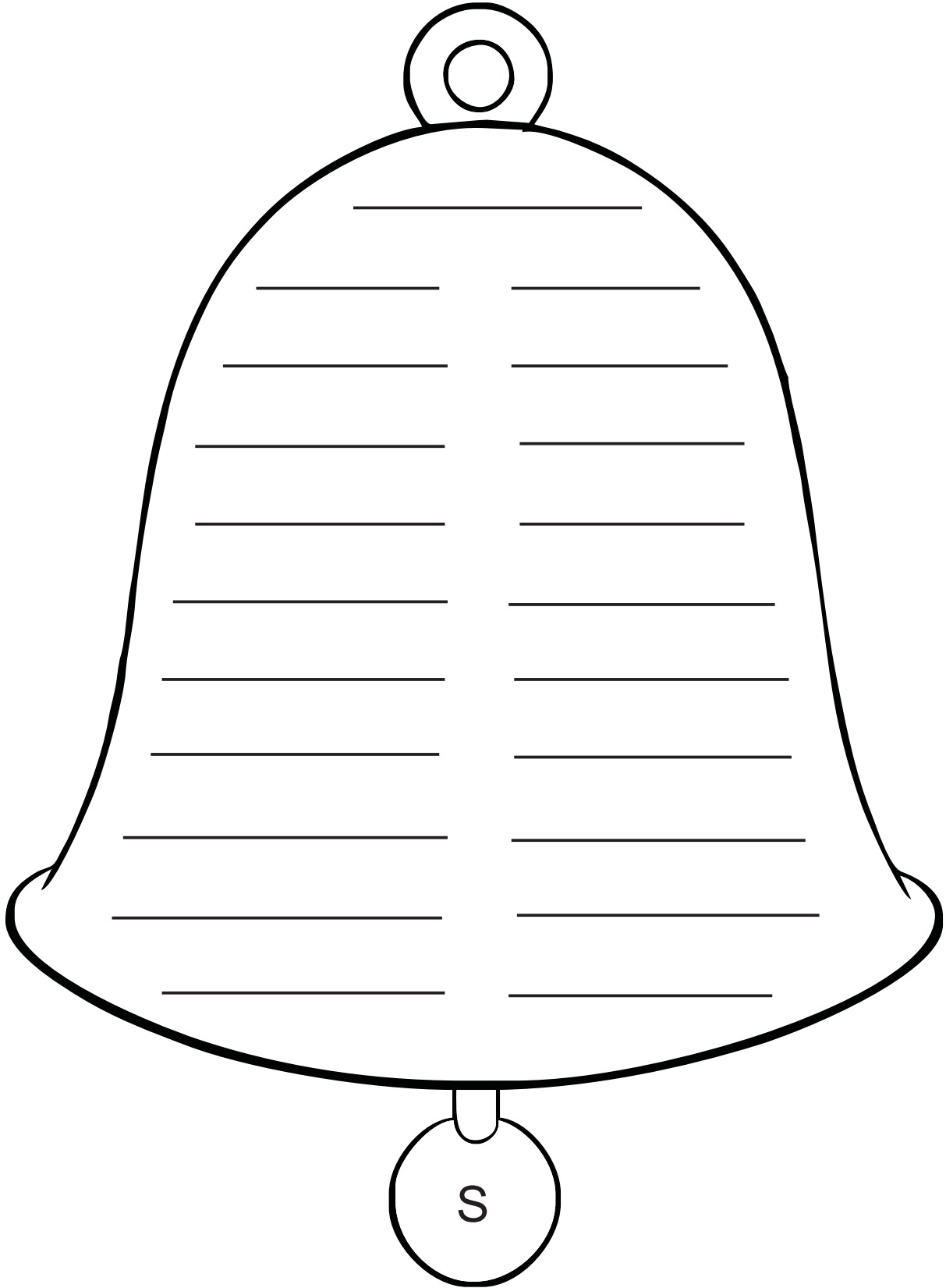

C b v H a B q A C u z m O X

a q u b A C S z m X N O p c G V

p

c

ç

z

o

g

s

a

s

u

d

q

n

g

ç

h

C b v H a B q A C u z m O X

TUTU MARAMBÁ

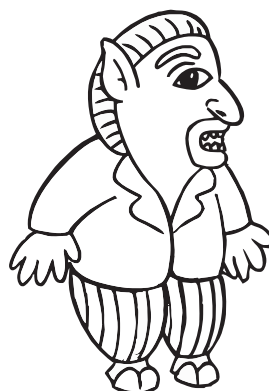

TUTU MARAMBÁ
NÃO VENHA MAIS CÁ,
QUE O PAI DA MENINA
TE MANDA MATAR.

(As Melhores Cantigas, Ciranda Cultural, pág. 44)

COPIE A PALAVRA.

TUTU -

Tutu

tutu

COPIE A LETRA **T - t**.

T -

T -

t -

t -

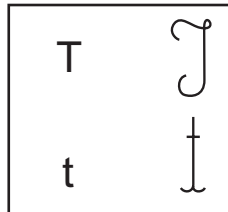
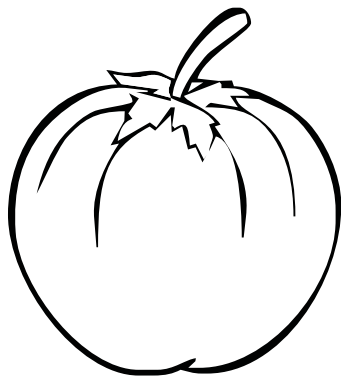

JUNTE A LETRA **T - t** COM AS VOGAIS
E FORME A FAMÍLIA SILÁBICA.

+	A	E	I	O	U
T					

COPIE.

TA - TE - TI - TO - TU

ta - te - ti - to - tu

+	a	e	i	o	u	ão
t						

ta - te - ti - to - tu - tão

ta - te - ti - to - tu - tão

LEIA AS PALAVRAS ESCRITAS NO DESENHO DA TELA.
DEPOIS ESCREVA-AS, NO QUADRO ABAIXO, DE
ACORDO COM AS SÍLABAS DESTACADAS.

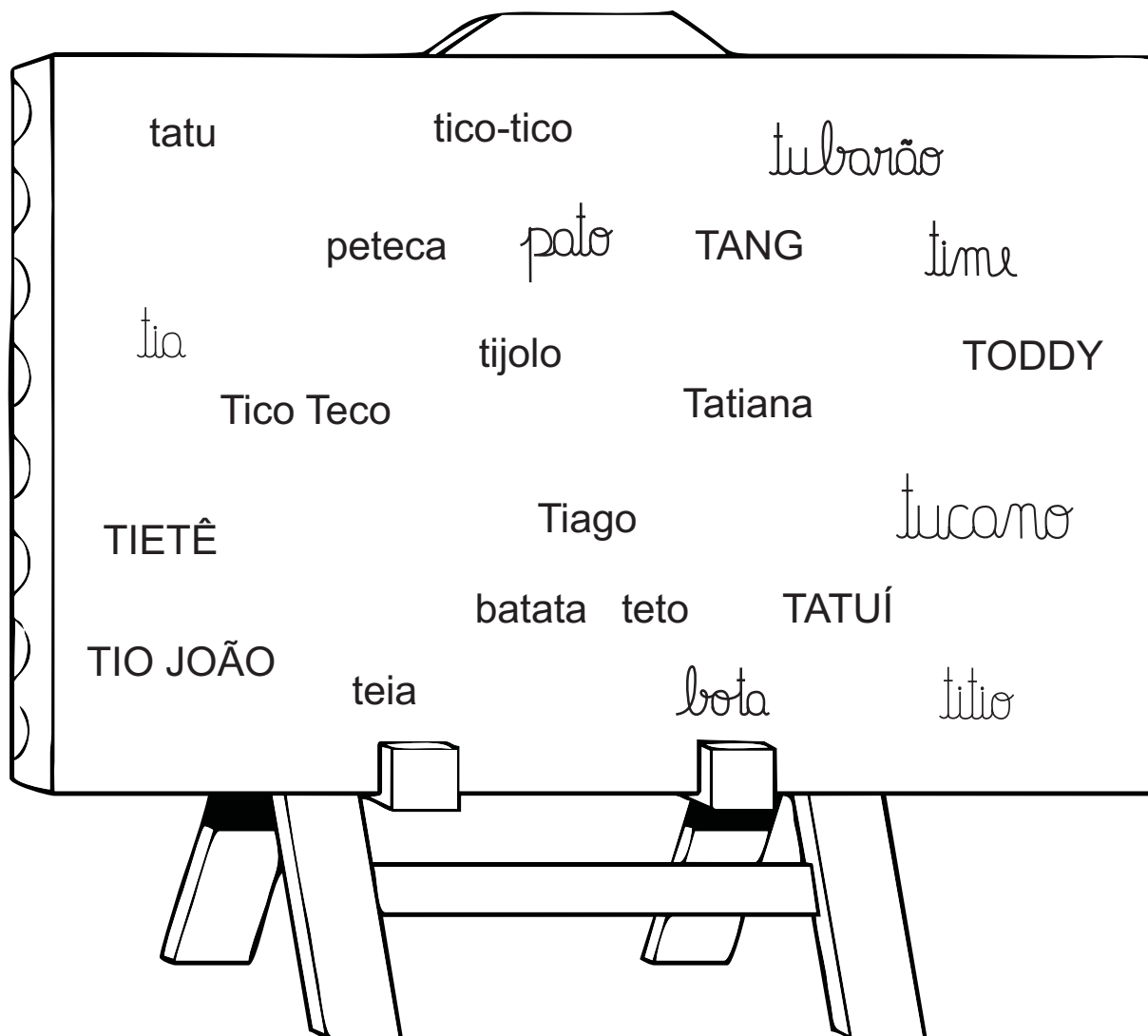

COPIE AS PALAVRAS ESCRREVENDO-AS
NOS QUADROS ABAIXO.

TA	TE	TI	TO	TU

JUNTE AS SÍLABAS DE ACORDO COM AS FIGURAS E ESCREVA AS PALAVRAS FORMADAS.



PINTE SOMENTE OS DESENHOS CUJAS PALAVRAS TÊM SÍLABAS DA FAMÍLIA DA LETRA **T - t**.



JUNTE AS SÍLABAS E ESCREVA AS PALAVRAS. USE UMA COR DIFERENTE PARA PINTAR AS SÍLABAS DE CADA PALAVRA.

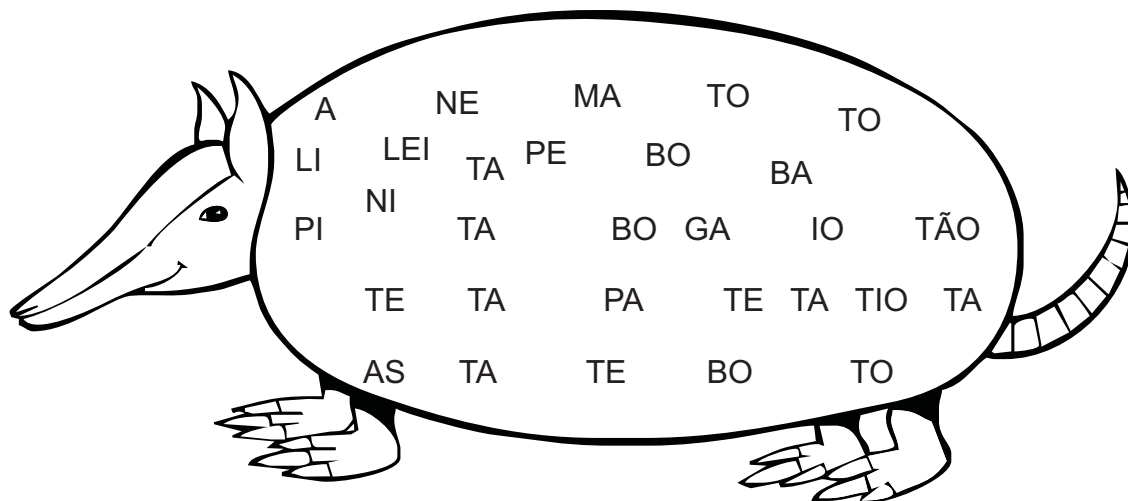

COMPLETE AS PALAVRAS ESCRIVENDO A SÍLABA QUE FALTA. ELAS PERTENCEM À FAMÍLIA DA LETRA **T - t**.

___ PE ___	___ MA ___	___ PA	BO ___ NA
GA ___	___ BARÃO	BA ___	LEI ___
SABONE ___	PE ___ CA	ABACA ___	___ CANO
___ ME	LA ___	TE ___	API ___
___ JOLO	___ URO	PO ___	___ IA

ESCREVA UMA PALAVRA INICIADA COM AS SÍLABAS EM DESTAQUE.



TA	_____
TE	_____
TI	_____
TO	_____
TU	_____



TA	_____
TE	_____
TI	_____
TO	_____
TO	_____

ORDENE AS SÍLABAS E FORME PALAVRAS.

TE | LEI

BO | TA | NI

NE | CA | TA

TE | NOI

TE | A | CA | BA

TE | MA | TO

SOU | TE | RA

JO | LO | TI

TÃO | BO

PA | SA | TO

RO | TOU

BA | TU | RÃO

LEIA AS PALAVRAS E DEPOIS ESCREVA-AS NO QUADRO,
OBSERVANDO AS LETRAS **T - D**.

ABACATE

TAPETE

DOCE

TUCANO

TESOURA

BOTINA

LADO

DIABO

DITADO

SÁBADO

TUDO

PETECA

BODE

SAPATO

GAVETA

GADO

TIJOLO

TIGELA

FADA

DIA

T

D

ESCREVA OS NOMES DE ACORDO COM O DESENHO,
SEPARANDO AS PALAVRAS EM SÍLABAS.

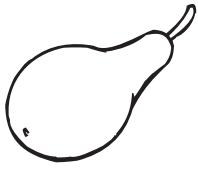

--	--	--	--

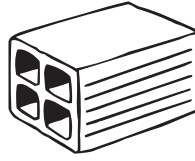

--	--	--

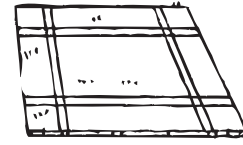

--	--	--



--	--	--

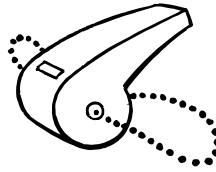

--	--	--

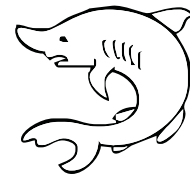

--	--	--



--	--	--



--	--

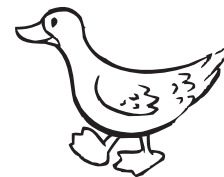

--	--

LEIA AS FRASES E FAÇA OS DESENHOS CORRESPONDENTES.

O TUCANO COME BANANA.

NA TIGELA TEM TOMATE.

O APITO É NOVO.

O GATO DORME NO TAPETE.

DESCUBRA QUAIS PALAVRAS PODEM SER FORMADAS

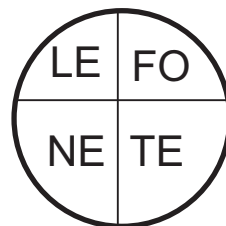
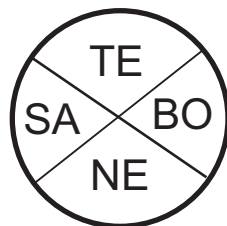
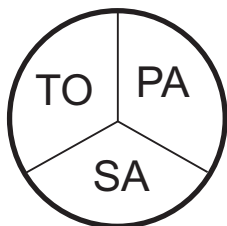
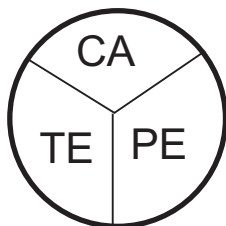

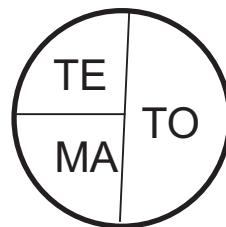
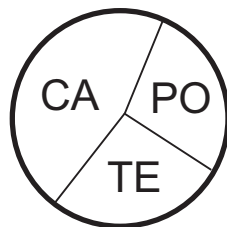
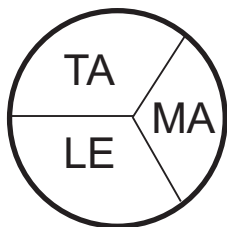
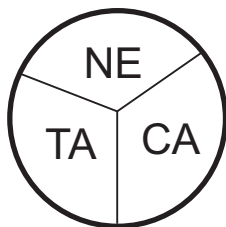

DESCUBRA, NAS PALAVRAS, AS SÍLABAS EM DESTAQUE E FAÇA UM CÍRCULO EM VOLTA.

TA	ITAIPU - GATA BATAVO - GAITA SETA - NOTA	DA	PIADA - MOEDA DANONE - IDADE MODA - NADA
TE	PETECA - POTE TELEFONE - SETE CAPOTE - NOITE	DE	PODE - MAMADEIRA TADEU - DEDO CADEADO - IDADE
TI	SÍTIO - CUTIA QUATI - SAPOTI TINA - TIME	DI	DICA - MEDIDA SADIA - DITADO DIA - PEDIDO
TO	PATO - GATO APITO - TOMADA GAROTO - PEITO	DO	MELADO - DOIDO MEDO - MUDO DOMINÓ - DONA
TU	TUDO - TUBO TUCANO - TATU TUPI - TUBARÃO	DU	CADUCO - DUNA DULCE - DUELO ADUBO - DUQUE

SUBSTITUA OS DESENHOS PELAS PALAVRAS
CORRESPONDENTES E ESCREVA AS FRASES.

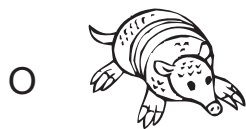







COMPLETE AS PALAVRAS COM **D** OU **T**.
DEPOIS, ESCREVA-AS ABAIXO DOS QUADROS.

BO ___ E
BO ___ E

SE ___ E
SE ___ E

___ IA
___ IA

GA ___ O
GA ___ O

SE ___ A
SE ___ A

DA ___ A
DA ___ A

MO ___ O
MO ___ O

PO ___ E
PO ___ E

LEIA AS SÍLABAS E PINTE-AS NAS PALAVRAS ABAIXO. PARA CADA SÍLABA, USE UMA COR DIFERENTE.



BONITÃO	TUBARÃO	TESOURA	CANETA
BATATA	TOMATE	TIJOLO	TODDY
LEITE	BOTÃO	GATO	TIGELA
TUCANO	TICO-TICO	TUDO	BOFETÃO
PATA	TAPETE	TIME	PETECA

ESCREVA OS NOMES DOS DESENHOS E SEPRE AS PALAVRAS EM LETRAS E SÍLABAS.

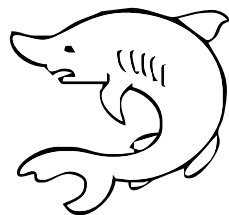





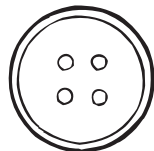



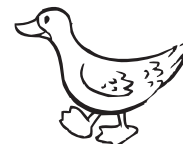



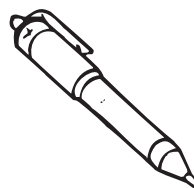



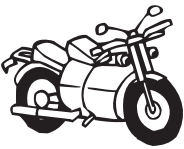
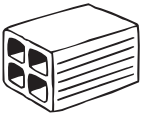

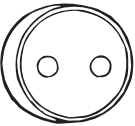

CIRCULE AS PALAVRAS QUE CORRESPONDEM
AOS DESENHOS E DEPOIS COPIE-AS.

	FOTO MOTO MATO TATO		TAPETE TOMATE BOTA TIJOLO		TATU FATO GATO DEDO
	TUCANO TAPETE TIJOLO TOMATE		DATA FOTO MATA MEDO		TELHADO TIME SAPATO SAPO
	TIGELA TOMADA TAPETE TUCANO		TIJOLO TIGELA BOTÃO TATU		TIME TUDO TOMADA TOMATE

ESCOLHA AS PALAVRAS CORRETAS E COMPLETE AS FRASES.

TUCANO - TOMADA - BOTÃO - TAPETE

O BEBÊ PÔS O DEDO NA _____ E LEVOU UM CHOQUE.

TIJOLO - MOTO - SAPATO - PETECA

A _____ É FEITA DE PENA.

TELHADO - TELHA - TIGELA - TOMATE

O GATO SUBIU NO _____.

LATÃO - BOTÃO - SABÃO - GATÃO

O _____ DA CAMISA DO PAPAÍ CAIU.

CIRCULE AS FRASES QUE ESTÃO DE ACORDO COM OS DESENHOS E DEPOIS COPIE-AS.

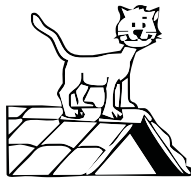

A PETECA É DE PENA.
O GATO MIA, MIA, EM CIMA DO TELHADO.
O TITIO TOCA TUBA.

O SAPATO DO TITIO É NOVO.
O TELEFONE TOCOU.
O GATO PEGOU O RATO.

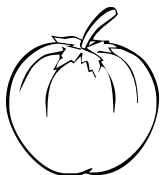

TALITA GOSTA DE TOMATE.
O ALICATE ESTÁ AMOLADO.
A SALADA DE TOMATE ESTÁ NA TIGELA.

FORME PALAVRAS TERMINADAS COM AS SÍLABAS DESTACADAS.

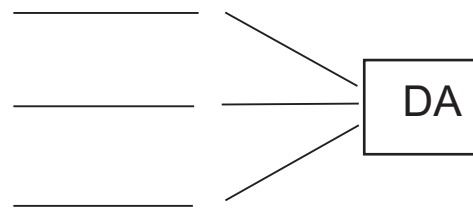
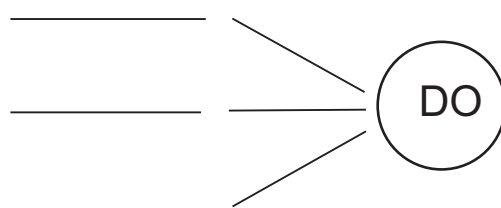
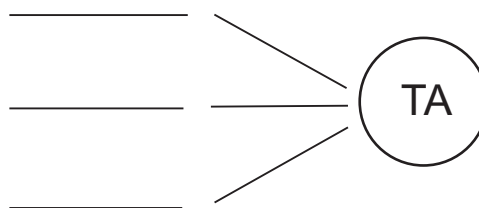
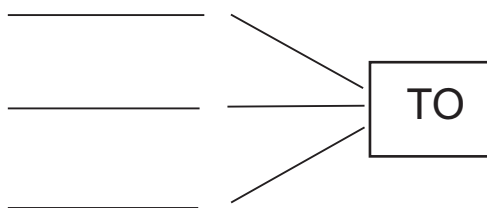

LIGUE O NOME AO DESENHO CORRESPONDENTE.
DEPOIS, COPIE AS PALAVRAS E SEPRE-AS EM SÍLABAS.

TAPETE



TOMATE

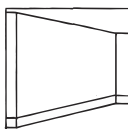

PATO

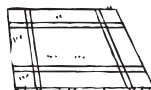

TUBARÃO



PAREDE



TEIA



ESCREVA PALAVRAS NOS DESENHOS ABAIXO. OBSERVE QUE ELAS DEVEM TER A LETRA **T E D**.

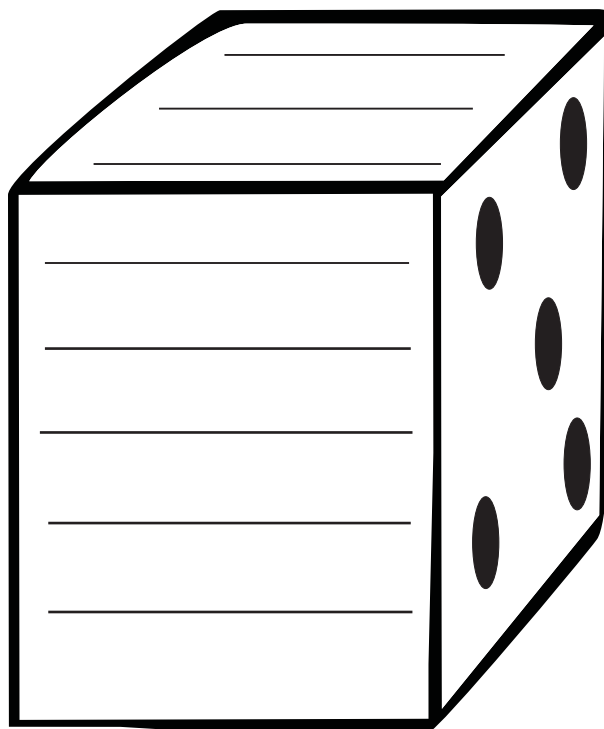
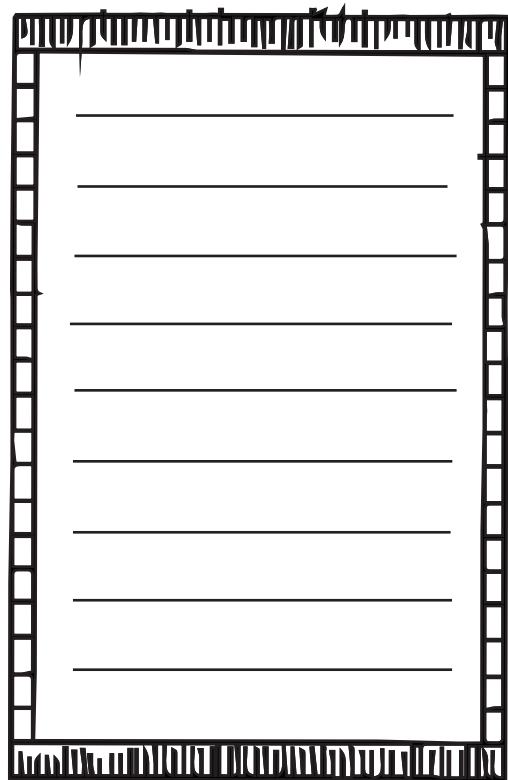

CAÇA – PALAVRAS

PINTE CADA PALAVRA EM UMA COR DIFERENTE. PINTE-AS TAMBÉM NO QUADRO DE PALAVRAS

X	Y	R	S	L	T	I	M	E	R
T	A	P	E	T	E	N	S	Z	T
U	W	Z	M	O	L	P	X	W	I
C	Q	K	N	M	A	V	Y	M	T
A	L	A	T	A	T	U	B	A	I
N	M	P	Q	T	O	M	A	D	A
O	A	J	N	E	T	E	T	A	K
Q	T	I	J	O	L	O	A	Z	Q
T	O	T	Ó	R	P	A	T	O	X
A	Y	T	I	T	I	O	A	V	W

TELA	LATA	TOMATE	PATO
TAPETE	TIME	TETA	TUBA
MATO	TIJOLO	BATATA	TOMADA
TITIO	TUCANO	TITIA	TOTÓ

AUTODITADO

ESCREVA PALAVRAS QUE TENHAM
SÍLABAS DA FAMÍLIA DA LETRA **T - t**.

A grid for a word search puzzle. The grid is a large square divided into a 4x4 grid of smaller squares. Each small square is further divided into four triangles by two diagonal lines. The top and bottom edges of the grid are filled with a decorative pattern of vertical lines. There are 12 numbered boxes for writing words, arranged in a 3x4 grid within the main grid:

- Row 1: Box 1 (top-left), Box 2 (top-right)
- Row 2: Box 3 (middle-left), Box 4 (middle-right)
- Row 3: Box 5 (bottom-left), Box 6 (bottom-right)
- Row 4: Box 7 (second row from bottom), Box 8 (second row from bottom)
- Row 5: Box 9 (third row from bottom), Box 10 (third row from bottom)
- Row 6: Box 11 (bottom row), Box 12 (bottom row)

a q u b A C S Z m X N O P C G V

É HORA DO DITADO.

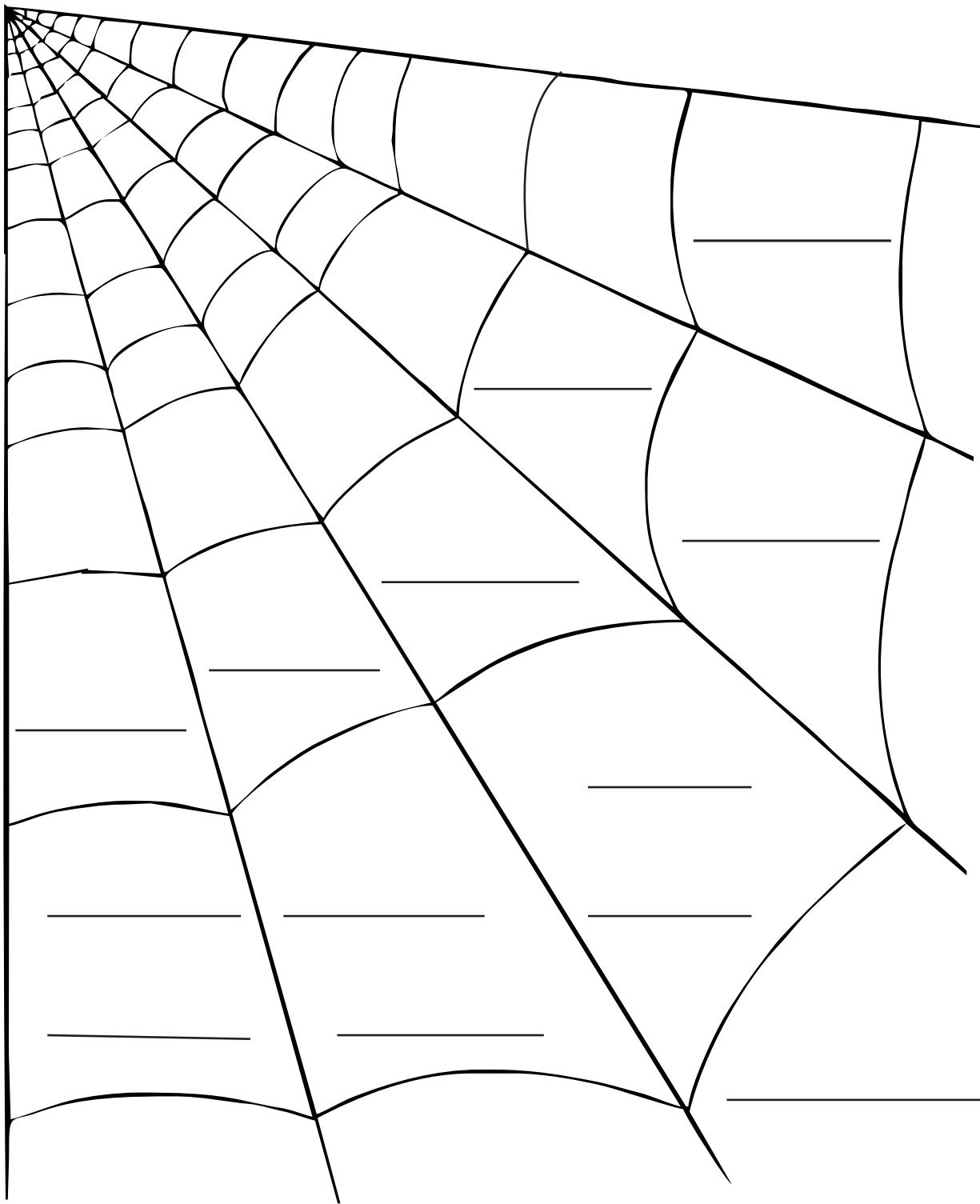

C b v H a B q A C u z m O X

a q u b A C S z m X N O p c g V

VACA MIMOSA

A VAQUINHA MIMOSA
ESTÁ NO PASTO A PASTAR.
DE REPENTE, ELA MUGE:
- MUUU! MUUU! MUUU!
ESTÁ CHAMANDO O BEZERRINHO,
VEM DEPRESSA,
VEM MAMAR.

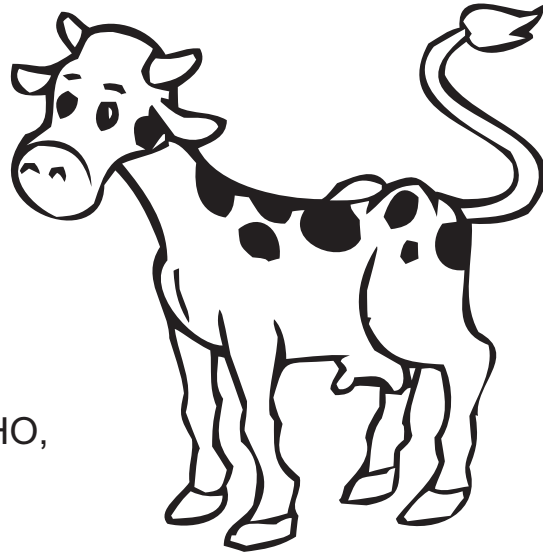

COPIE A PALAVRA.

vaquinha –

vaquinha

COPIE A LETRA **V - v**.

V

U

v

u

C b v H a B q A C u z m O X

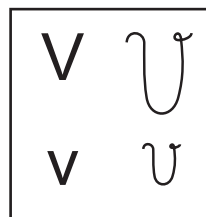
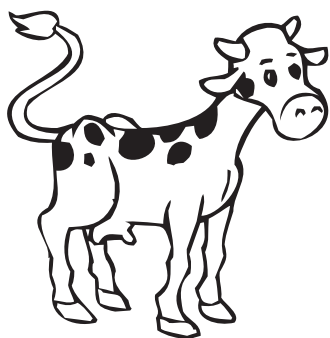

JUNTE A LETRA **V - v** COM AS VOGAIS E
FORME A FAMÍLIA SILÁBICA.

+	A	E	I	O	U
V					

COPIE.

VA - VE - VI - VO - VU

Va Ve Vi Vo Vu

+	a	e	i	o	u	ão
v						

va - ve - vi - vo - vu - vão

va - ve - vi - vo - vu - vão

LEIA AS PALAVRAS ESCRITAS NO DESENHO E DEPOIS ESCREVA-AS NOS QUADROS, DE ACORDO COM AS SÍLABAS EM DESTAQUE.

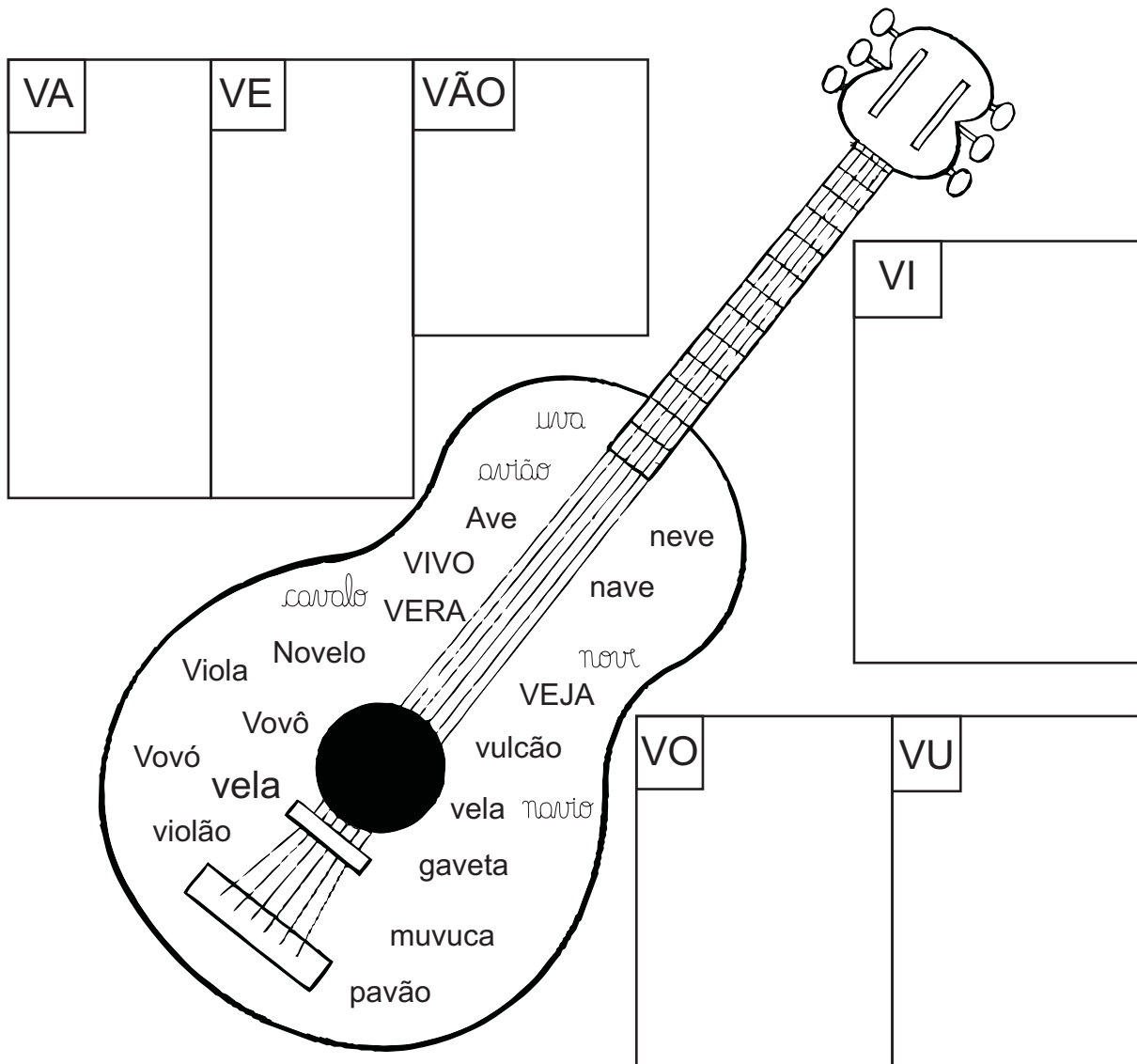

LIGUE ÀS SÍLABAS E FORME PALAVRAS.

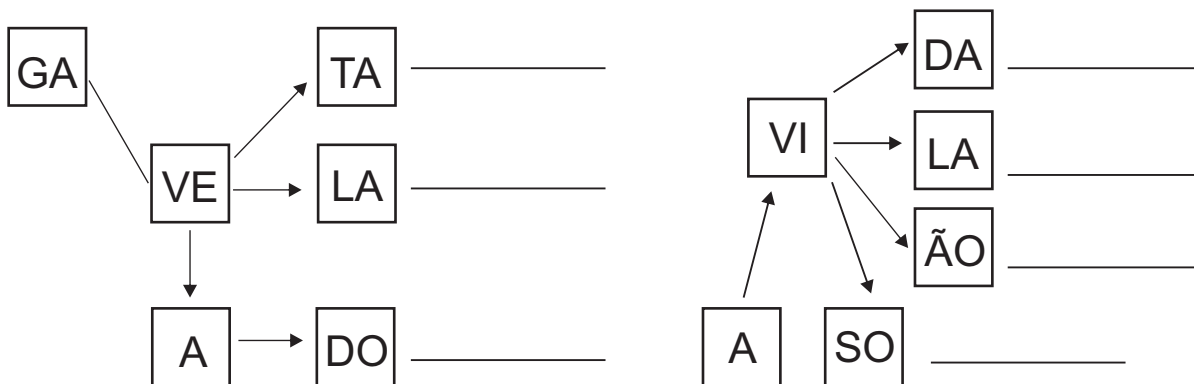

a q u b A C S Z m X N O P C G V

ESCREVA O NOME DOS DESENHOS E SEPRE AS PALAVRAS EM SÍLABAS.



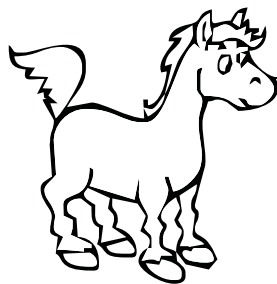

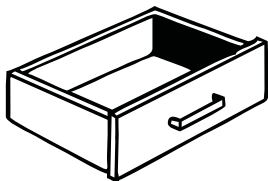

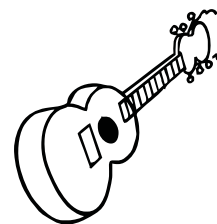











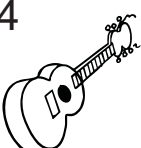
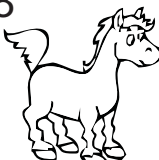

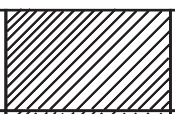
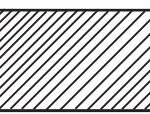
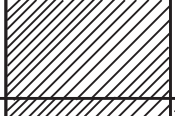

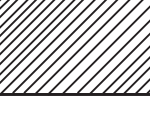
ESCREVA O NOME DOS DESENHOS COLOCANDO AS SÍLABAS DE ACORDO COM OS NUMERAIS.

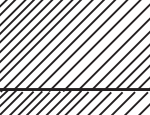
1 	5 
2 	6 
3 	7 
4 	8 

1				
2				
3				
4				
5				
6				
7				
8				

C b v H a B q A C u z m O X

ESCREVA AS SÍLABAS QUE FALTAM NAS PALAVRAS, DE ACORDO COM OS DESENHOS.

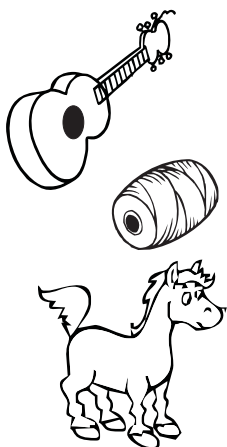

	O	LÃO
NO		LO
CA		LO
A		ÃO
GA		TA
FI		LA

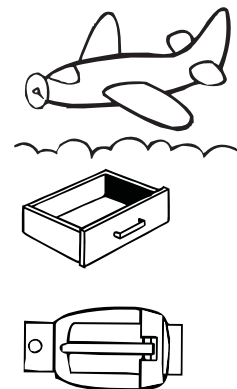

CIRCULE OS NOMES DOS DESENHOS E COPIE AS PALAVRAS CIRCULADAS.

NATA
NAVIO
NAVE
FACA

VACA
VASO
VALE
FACA

PELA
MELA
TELA
VELA

VOCÊ
OVO
VOVÔ
NOVO

CAVALO
BATAVO
NOVELO
FALAVA

VASO
NOVE
NEVE
NAVE

LEIA AS PALAVRAS ESCRITAS NESTA PÁGINA E COPIE DUAS PALAVRAS COM AS SÍLABAS INDICADAS.

(LA)	(VI)
(VE)	(VO)

ENCONTRE E ESCREVA ABAIXO AS PALAVRAS QUE ESTÃO ESCONDIDAS NO DESENHO.

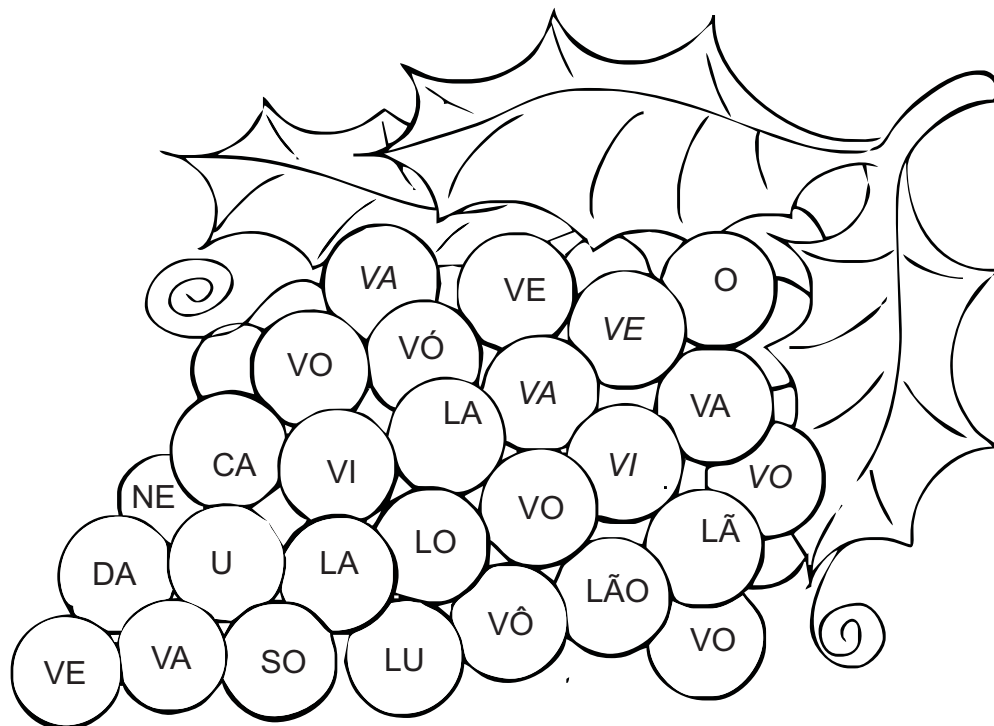

PINTE AS SÍLABAS QUE FORMAM OS NOMES DOS DESENHOS.

	VI	VE
	VO	VU
	FA	VÓ
	NO	VI
	FE	VE
	LO	VO

	VU	LA
	VE	VI
	VA	FE
	FI	VI
	O	VO
	VA	LÃO

	CA	VO
	VA	VU
	CO	LO
	FA	VA
	SO	VE
	VO	VI

ESCOLHA AS PALAVRAS CORRETAS
PARA COMPLETAREM AS FRASES ABAIXO.

VIOLÃO - NEVE - AVIÃO - VASO

O VOVÔ TEM MEDO DE VIAJAR DE _____.

NOVELO - NAVIO - VELA - VIOLÃO

A VOVÓ E O VOVÔ JÁ VIAJARAM DE _____.

VALE - NEVADO - FIVELA - PAVÃO

O _____ É UMA BELA AVE.

VIVO - VACA - VIOLÃO - BATAVO

VOVÔ TOCA GAITA E _____.

COMPLETE AS PALAVRAS ESCRREVENDO AS SÍLABAS QUE
FALTAM, DE ACORDO COM OS DESENHOS.



CA



LA

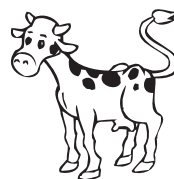

CA



CA



NO LO

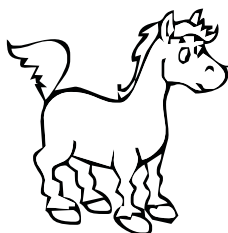

CA LO



TA

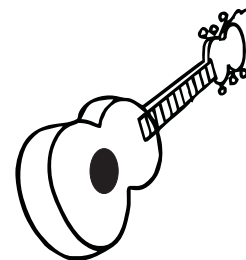

O LÃO

LEIA AS PALAVRAS ABAIXO E COPIE-AS DE ACORDO COM A FAMÍLIA DAS LETRAS A QUE PERTENCE.

FACA	UFA	FALA	VILA
VALE	VIDA	FERA	FOTO
VERA	FILA	VACA	VALA
FITA	FALE	VOTO	UVA

F		V	
---	--	---	--

NUMERE OS DESENHOS DE ACORDO COM AS FICHAS DAS PALAVRAS.

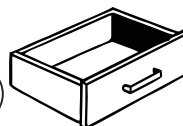
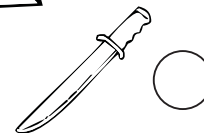
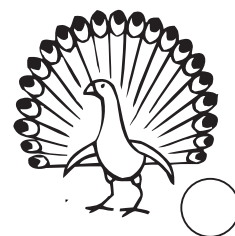
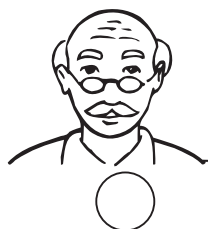
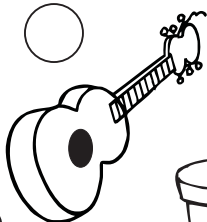
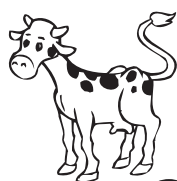

- | |
|------------|
| 1 - VELA |
| 2 - GAVETA |
| 3 - FACA |
| 4 - VASO |
| 5 - VOVÔ |
| 6 - FITA |
| 7 - VACA |
| 8 - VIOLÃO |
| 9 - FOTO |
| 10 - PAVÃO |

ESCREVA, NO QUADRO ABAIXO, AS PALAVRAS QUE VOCÊ PODE FORMAR JUNTANDO AS SÍLABAS QUE ESTÃO NO DESENHO DO PAVÃO.

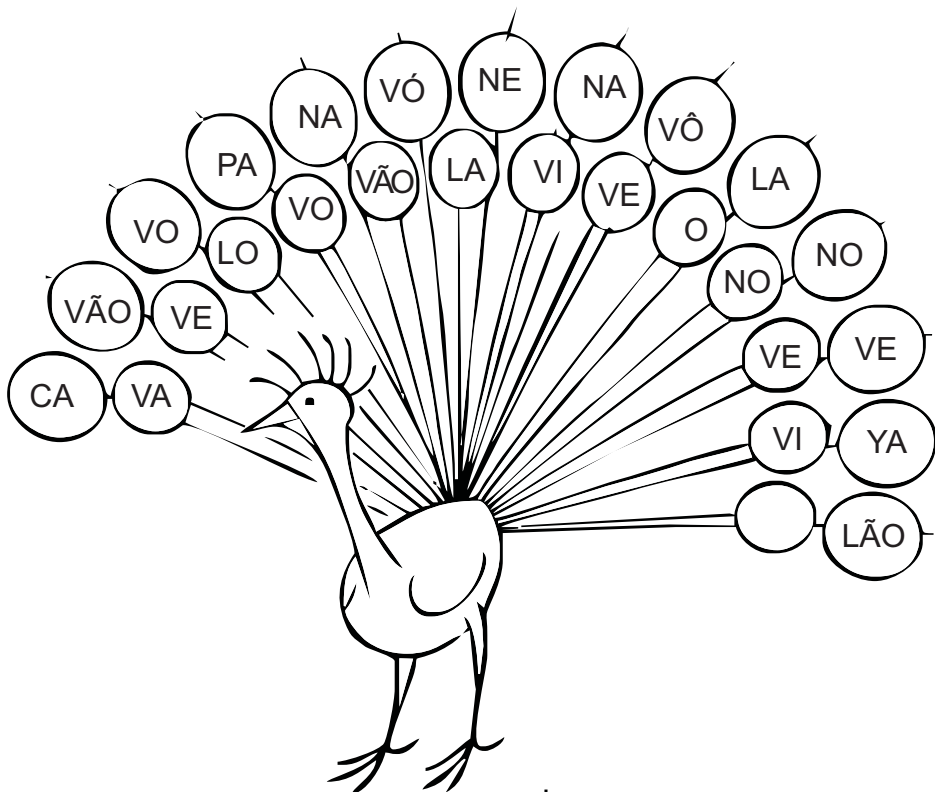

ESCREVA AS PALAVRAS DAS FICHAS NO LUGAR CORRETO.

FOTO
VALA

_____ DO BEBÊ.
 _____ NA CALÇADA.

VACA
FACA

_____ AFIADA.
 _____ LEITEIRA.

VILA
FILA

_____ DA CIDADE.
 _____ ENORME.

FITA
VIDA

_____ ALEGRE.
 _____ DO CABELO.

LEIA AS SÍLABAS QUE ESTÃO NOS VASOS E PINTE-AS NAS PALAVRAS ABAIXO. USE UMA COR DIFERENTE PARA CADA SÍLABA.

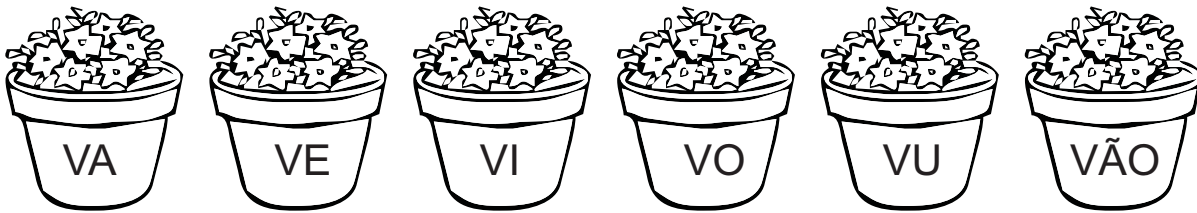

VOVÓ	CAVALO	VINHO	PAVÃO
VASO	NOVO	OVO	MUVUCA
GAVETA	VALE	NOVELO	VOCÊ
NOVA	VELA	AVIÃO	NEVE
LUVÃO	VIOLÃO	VIDA	VULCÃO

ESCOLHA SEIS PALAVRAS DO QUADRO. DEPOIS, COPIE SEPARANDO EM SÍLABAS.

LIGUE AS PALAVRAS ÀS SÍLABAS CORRESPONDENTES E COPIE-AS AO LADO.

GAVETA	DA VI	
VIDA	VA CA LO	
VELA	VE GA TA	
CAVALO	LA VE	
NOVELO	LÃO VI O	
PAVÃO	VA LU	
VIOLÃO	NO LO VE	
LUVA	VÃO PA	

LEIA AS PALAVRAS, PINTE CADA SÍLABA
COM UMA COR E ESCREVA NO QUADRINHO
QUANTAS SÍLABAS TÊM AS PALAVRAS.

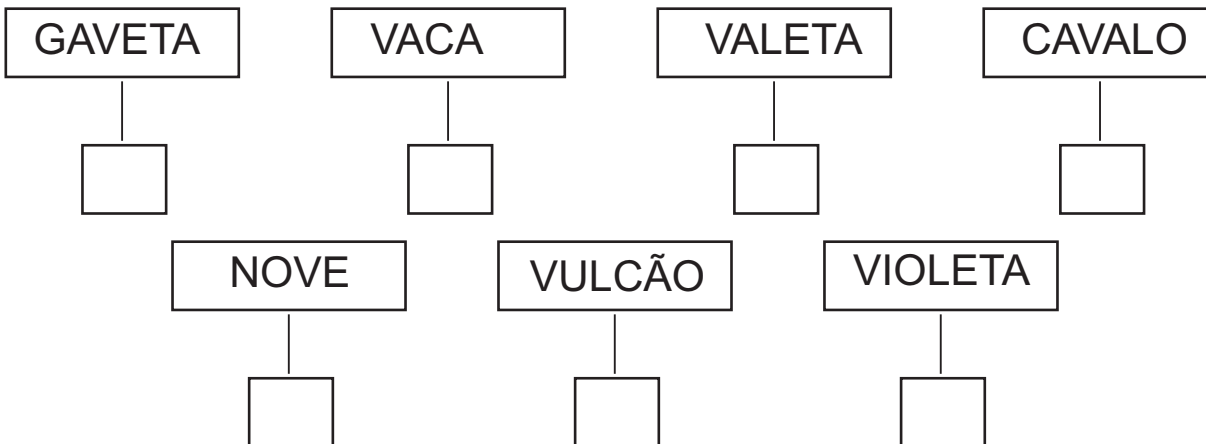

ESCOLHA UMA PALAVRA DO QUADRO
DESENHAR E ESCREVER O NOME.

_____	<p>VACA</p> <p>VELA</p> <p>VIOLÃO</p>	_____	<p>LUVA</p> <p>NEVE</p> <p>NOVO</p>
_____	<p>NOVE</p> <p>NOVO</p> <p>VOVÔ</p>	_____	<p>NAVIO</p> <p>UVA</p> <p>AVIÃO</p>
_____	<p>GAVETA</p> <p>VOVÓ</p> <p>VASO</p>	_____	<p>NOVELO</p> <p>CAVALO</p> <p>OVO</p>

ASSINALE AS SÍLABAS DA FAMÍLIA **V** NAS PALAVRAS ABAIXO.

VA - VE - VI - VO - VU - VÃO

AVIÃO	NEVE	VIDA	VOVÔ
GAVETA	NOVO	LUVA	NOVELO
CAVALO	PAVÃO	VASO	VILA
VIOLETA	VOVÓ	VIOLÃO	NOVE
UVAS	MUVUCA	OVELHA	NAVIO

LIGUE AS FICHAS PARA FORMAR FRASES.
 USE CORES DIFERENTES PARA CADA FRASE.
 DEPOIS, COPIE AS FRASES QUE VOCÊ FORMOU.

A	UVAS	NA	VIOLETA.
AS	LUVA	TEM	NEVE.
VÂNIA	VASO	É	VERDES.
NO	ESQUIOU	ESTÃO	FOFINHA.

CAÇA- PALAVRAS

PINTE CADA UMA DAS PALAVRAS COM COR DIFERENTE,
PINTE-AS, TAMBÉM, NO QUADRO DE PALAVRAS.

X	G	H	J	V	U	L	C	Ã	O
Z	V	A	S	O	B	D	G	H	J
W	E	I	K	V	N	A	V	I	O
B	J	L	Q	Ó	O	N	F	K	P
C	A	R	M	O	V	E	L	H	A
A	V	O	V	Ô	E	V	L	R	V
V	I	D	A	N	L	E	Q	T	Ã
I	O	F	C	P	O	Z	M	Y	O
S	L	S	A	U	X	X	Z	W	K
O	A	T	N	P	U	V	A	Z	X

AVISO	VOVÓ	OVELHA
VASO	NAVIO	VIDA
NEVE	VIOLA	VEJA
VACA	UVA	NOVELO
PAVÃO	VULCÃO	VOVÔ

a q u b A C S Z m X N O P C G V

AUTODIDATO

ESCREVA PALAVRAS QUE TENHAM
SÍLABAS DA FAMÍLIA DA LETRA **V - v**.

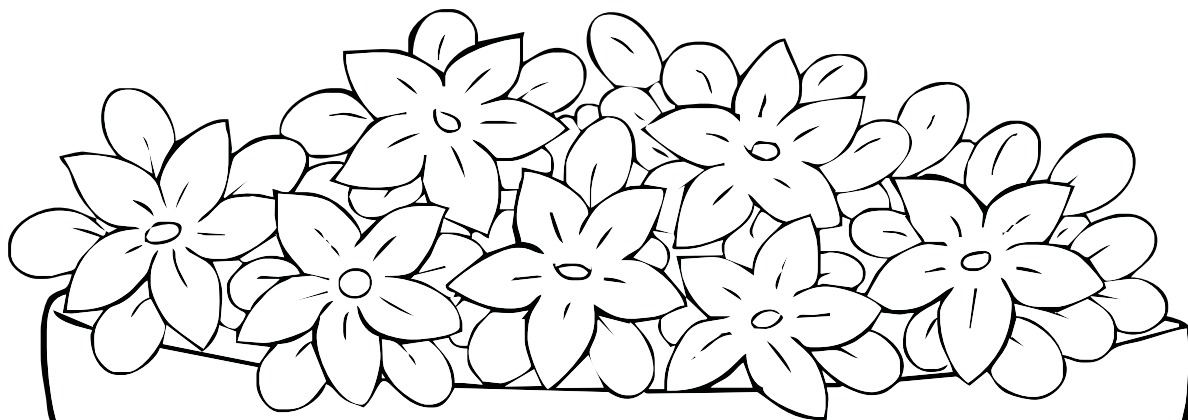

C b v H A B q A C u z m O X

É HORA DO DITADO

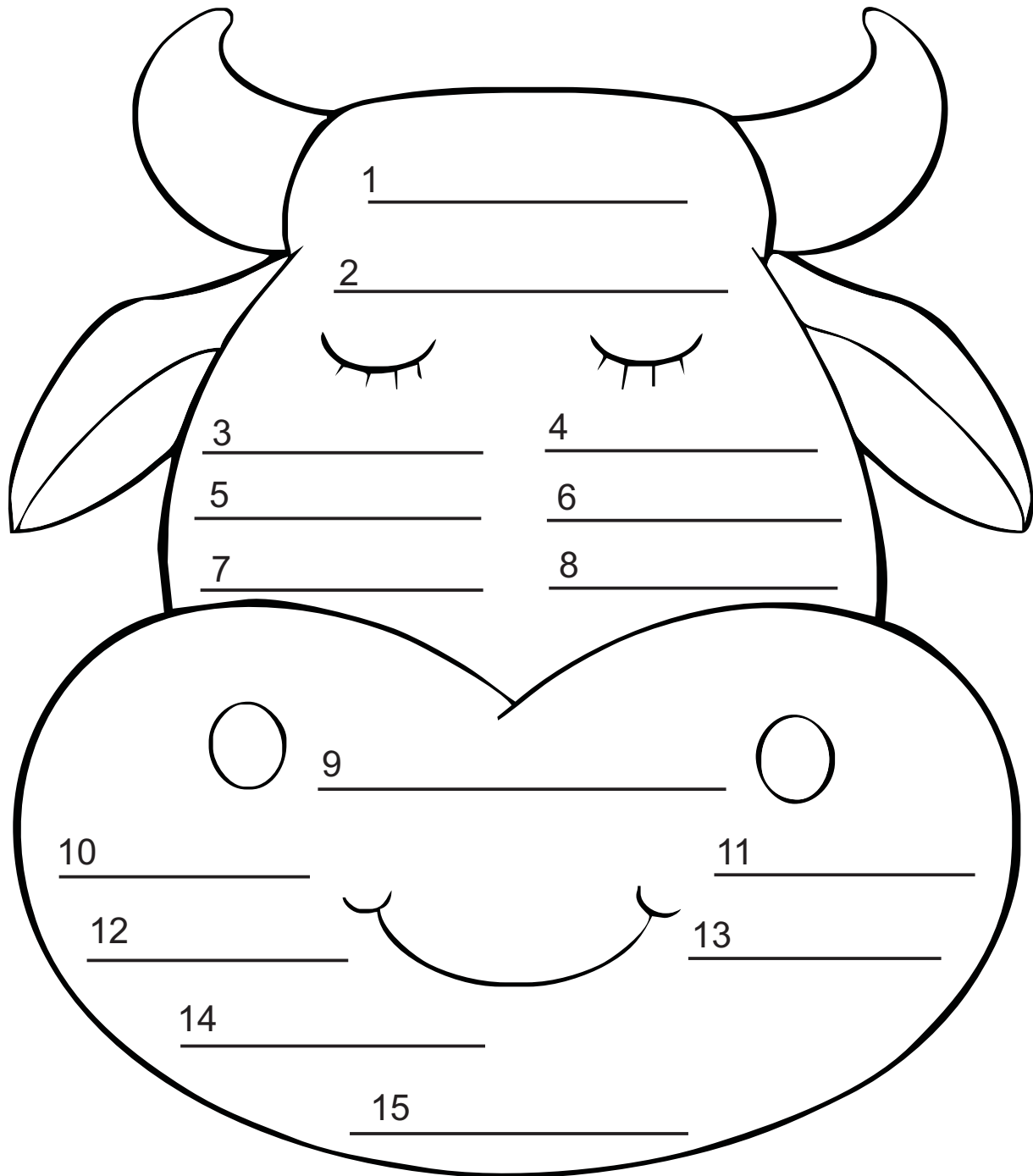

CARANGUEJO NÃO É PEIXE

CARANGUEJO NÃO É PEIXE
CARANGUEJO PEIXE É,
CARANGUEJO SÓ É PEIXE
NA VAZANTE DA MARÉ.

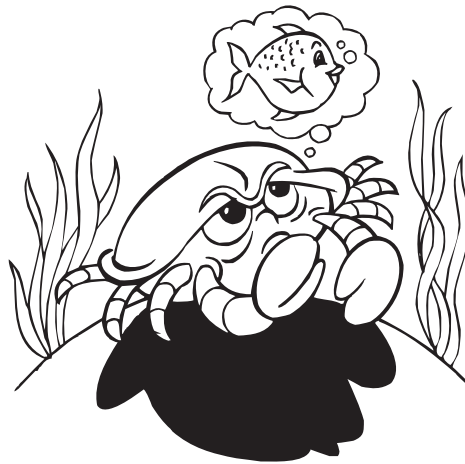

PALMA, PALMA, PALMA
PÉ, PÉ, PÉ.
RODA, RODA, RODA
CARANGUEJO PEIXE É.

(CD *As Mais Belas Cantigas de Roda*, Ciranda Cultural, pág. 26)

ASSINALE NO TEXTO A PALAVRA PEIXE.

COPIE:

peixe -

peixe -

P -

p -

p -

p -

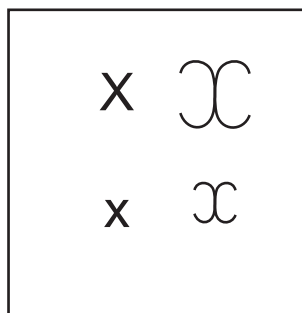
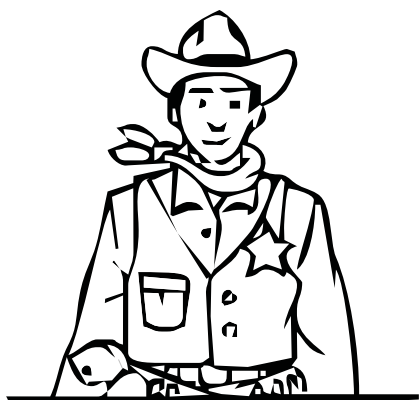

JUNTE A LETRA **X - x** COM AS VOGAIS E FORME A FAMÍLIA SILÁBICA.

+	A	E	I	O	U
X					

COPIE.

XA - XE - XI - XO - XU

xa - xe - xi - xo - xu

+	a	e	i	o	u	ão
x						

xa - xe - xi - xo - xu - xão

xa - xe - xi - xo - xu - xão

A BRUXA MISTUROU AS SÍLABAS NO CALDEIRÃO. VAMOS ESCREVER QUAIS SÃO AS PALAVRAS QUE PODEM SER FORMADAS.



ESCREVA OS NOMES DOS DESENHOS:

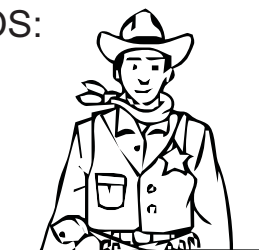
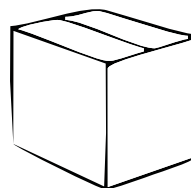
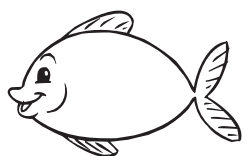

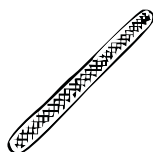

NOS DESENHOS DAS XÍCARAS ESTÃO ESCRITAS VÁRIAS PALAVRAS, LEIA E DEPOIS COPIE-AS NAS XÍCARAS, DE ACORDO COM AS SÍLABAS INDICADAS.

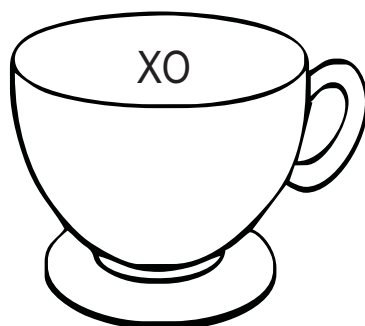
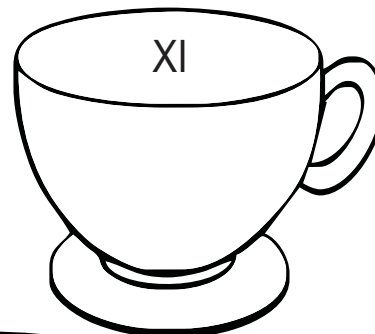
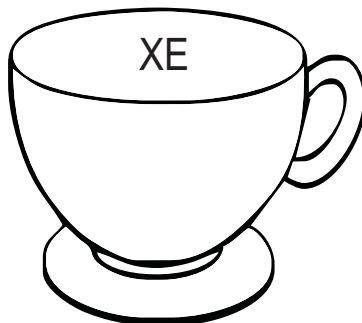
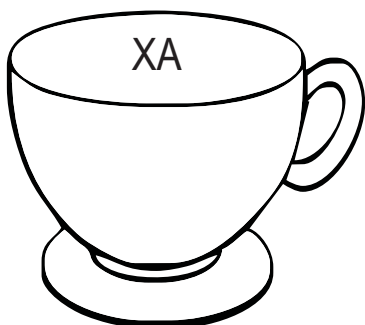

ESCREVA OS NOMES DOS DESENHOS E SEPRE AS PALAVRAS EM SÍLABAS.







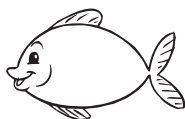



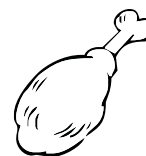

JUNTE AS SÍLABAS E ESCREVA AS PALAVRAS FORMADAS.

1 XE	6 PEI	11 A	3 - 5 - 1	6 - 1
2 LI	7 XU	12 FEI	2 - 4	7 - 4
3 MA	8 CAI	13 CA	4 - 10	2 - 9
4 XA	9 XO	14 MEI	8 - 4	12 - 1
5 XI	10 LE	15 RA	11 - 14 - 4	5 - 13 - 15

LIGUE AS SÍLABAS DAS FICHAS E ESCREVA AS PALAVRAS.

CAI	XA	TE	_____	XA	LE	_____
	XO	TÃO	_____		DREZ	_____
	XÃO	_____	_____		RÉU	_____
				VE	CO	_____
XE	RI	FE	_____	XO	DÓ	_____
	XÉU	_____	_____		TE	_____
	ROX	_____	_____			

LEIA AS PALAVRAS ESCRITAS NOS PEIXINHOS. ESCREVA-AS NO QUADRO ABAIXO, DE ACORDO COM AS SÍLABAS INDICADAS.

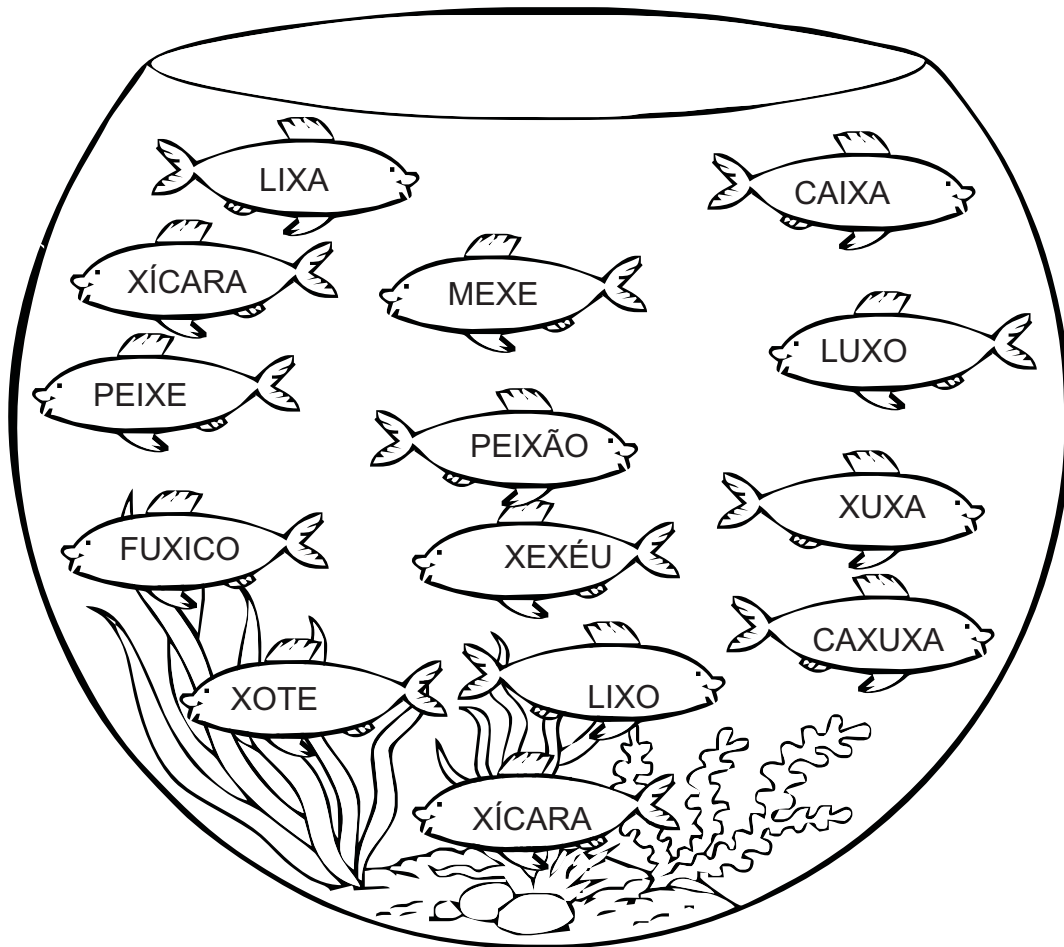

XA _____ _____ _____	XE _____ _____ _____	XI _____ _____ _____	XO _____ _____ _____
XU _____ _____ _____	XÃO _____ _____ _____	<p>ESCREVA OS NOMES DOS DESENHOS.</p>	

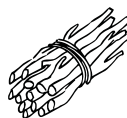
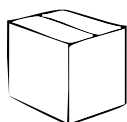

FORME PALAVRAS COM AS SÍLABAS DESTACADAS, NAS PALAVRAS ABAIXO.

peixe que rida bife

bebida abacaxi gato

avião bala casa xixi

caixa xarope pega

fada be xiga navio

furo abacaxi colega

COPIE AS PALAVRAS QUE PODEM SER ESCRITAS COM AS SÍLABAS ESCONDIDAS NAS BEXIGAS.

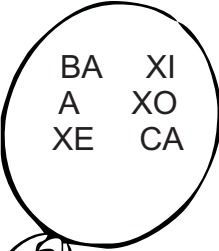
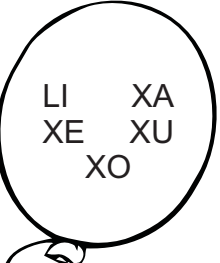
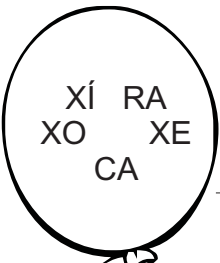
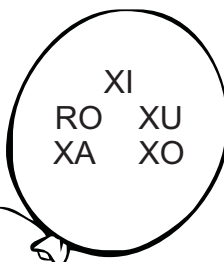
COMPLETE AS PALAVRAS COM
AS SÍLABAS ESCRITAS NOS PEIXINHOS.

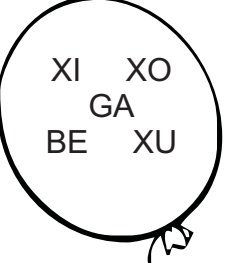
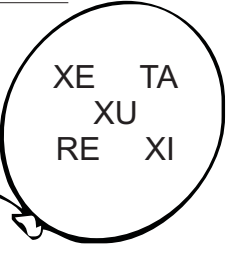
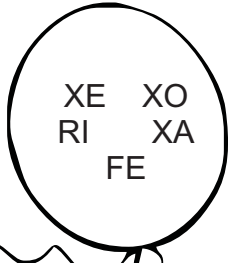
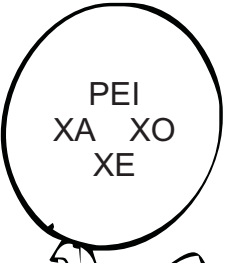

PEI _____

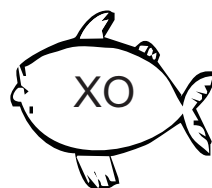
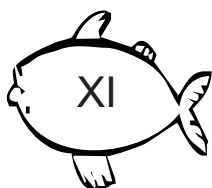
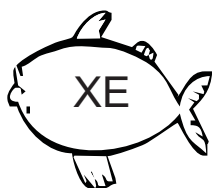
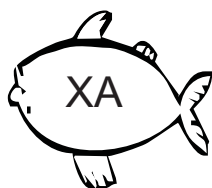
_____ LE

AMEI _____

FAI _____

FA _____ NA

CAI _____

LI _____

ABACA _____

TÁ _____

FEI _____

BAI _____ LA

MAXI _____

ME _____ DO

LU _____

_____ DÓ

EN _____ DA

EN _____ TO

_____ XA

SUBSTITUA OS DESENHOS POR PALAVRAS
E ESCREVA AS FRASES FORMADAS.

O



DA XÊNIA É UM LUXO.

PIXOXÓ PEGOU O



DA

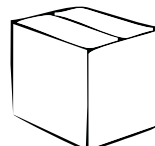

A



CAXUXA ASSUSTOU AS CRIANÇAS.

O



PIXOXÓ ESTOUROU A

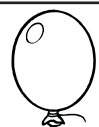

A MAMÃE FRITOU

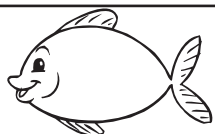

E FEZ SALADA DE MAXIXE.

SUBSTITUA OS DESENHOS PELAS PALAVRAS
CORRESPONDENTES. DEPOIS, COPIE AS FRASES FORMADAS.

O  MEXEU NA  E ROEU O 

ROXO DA VOVÓ.

VOVÓ FICOU DANADA DE RAIVA E JOGOU A  E O
 ROXO NO  .

COMPLETE AS FRASES COM AS PALAVRAS AO LADO.

XALE
XADREZ
XERIFE
ROXO
XÍCARA
BEXIGA
ABACAXI
ENXUTA
FAXINA
XUXA

A CASA DA _____ É LUXUOSA.

A FAXINEIRA FEZ _____ NA COZINHA.

O GATO XUXU ESTOUROU A _____.

VOVÔ JOGA _____ COM A VOVÓ.

O PALETÓ DE ZECA É _____.

ZUZA É O _____.

A MAMÃE SERVIU O CHÁ NA _____.

TITIA FEZ UM _____ NOVO DE LÃ.

XUXA GOSTA DE SUCO DE _____.

A ROUPA DO VARAL JÁ ESTÁ _____.

PINTE AS SÍLABAS QUE FORMAM AS PALAVRAS
DE ACORDO COM OS DESENHOS.
DEPOIS, COPIE AS PALAVRAS.



XÍ XO CA RA MA

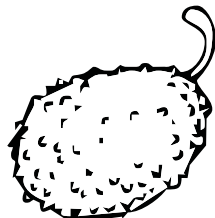

XO MA MO XI XE

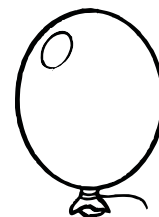

BE XO XI XU GA

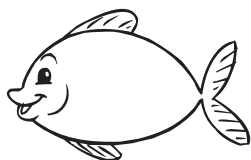

TEI PEI XA XE



TE XE XI RI FE



FU XI RO CA CO

FORME PALAVRAS COM AS SÍLABAS QUE
ESTÃO CIRCULADAS, ESCREVA-AS.
DEPOIS, SEPRE-AS EM SÍLABAS.

PEIXE

XALE

DADO

XERETA

XERIFE

BIFE

AVIÃO

BALA

CASA

BEXIGA

LUXO

XUXA

OVO

CASO

FADA

ABACAXI

NAVIO

CAIXA

XOTE

TEIA

a q u b A C S Z m X N O P C G V

LIGUE OS DESENHOS DE ACORDO COM AS SÍLABAS FINAIS DAS PALAVRAS E ESCREVA-AS NO QUADRO ABAIXO.

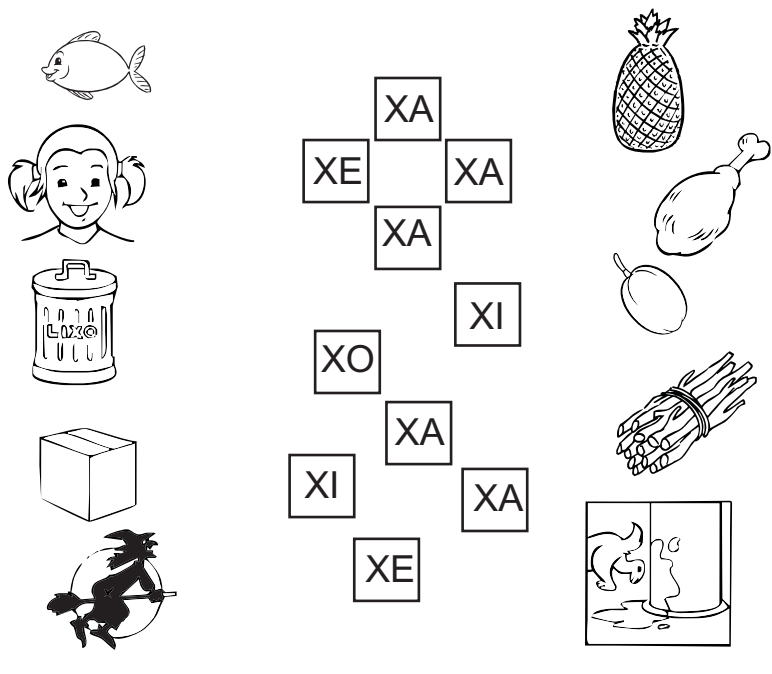

XA
XE XA XA
XA
XI
XO
XA
XI XA
XE

LEIA AS FRASES E DEPOIS COMPLETE-AS, DE ACORDO COM O QUE VOCÊ LEU. ENVOLVA NA LEITURA AS PALAVRAS COM **X**.

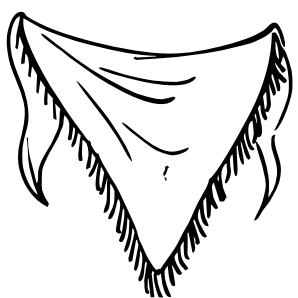

O XALE DA VOVÓ É ROXO.
XÊNIA DEU O XALE À VOVÓ.
O XALE É MUITO BONITO.
VOVÓ GUARDOU O XALE NA CAIXA.

O _____ DA VOVÓ É _____.
_____ DEU O _____ À VOVÓ.
O _____ É MUITO BONITO.
VOVÓ GUARDOU O _____ NA _____.

CIRCULE NA LEITURA AS PALAVRAS COM **X**.

C b v h a B q A C u z m O X

CIRCULE NAS PALAVRAS, AS SÍLABAS
QUE PERTENCEM À FAMÍLIA DA LETRA **X-x**.

BAIXA	LIXA	LIXÃO	REMEXE
XÊNIA	FEIXE	CAIXOTE	ABACAXI
XUXA	AMEIXA	FAXINA	XEPA
PEIXÃO	BEXIGA	COXA	BAIXO
LUXO	PAIXÃO	EIXO	CAIXÃO

COPIE AS PALAVRAS ACIMA, ESCRREVENDO-AS
DE ACORDO COM AS SÍLABAS CIRCULADAS.

XA	_____
XE	_____
XI	_____
XO	_____
XU	_____
XÃO	_____

SEPARE AS PALAVRAS EM SÍLABAS.

PEIXÃO	CAIXÃO	PAIXÃO	LIXÃO
REMEXE	FAXINA	ABACAXI	

LEIA AS PALAVRAS E DEPOIS COPIE-AS
ESCREVENDO DE ACORDO COM O NÚMERO DE SÍLABAS.

2 SÍLABAS

4 SÍLABAS

ABACAXI
PAIXÃO
FAXINA
LIXO
XALE
REMEXIDO
AMEIXA
PEIXE
FUXICO
CAIXOTE
PEIXARIA
XAROPINHO

3 SÍLABAS

LIGUE E FORME PALAVRAS ESCRIVENDO-AS AO LADO.

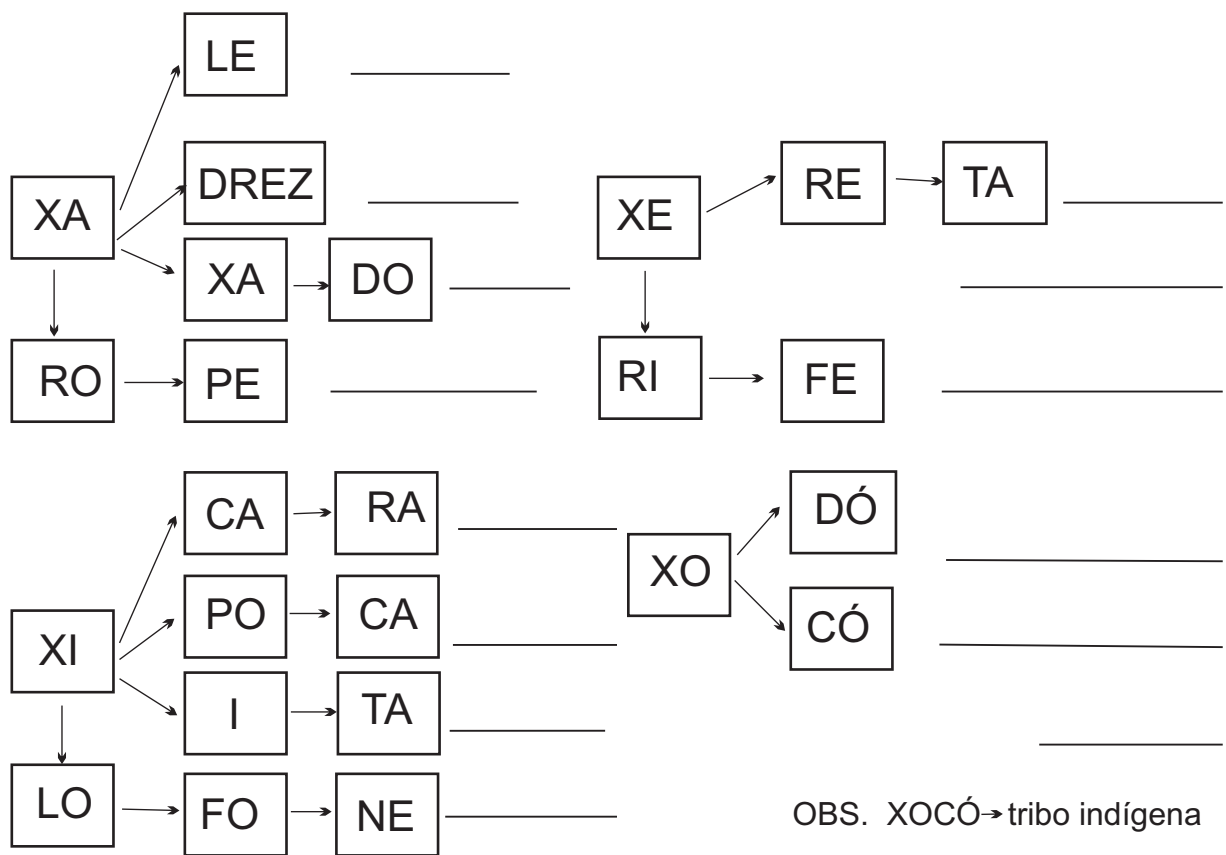

OBS. XOCÓ → tribo indígena

CAÇA- PALAVRAS.

Z	X	P	E	I	X	E	W	Z	X
A	Í	W	H	C	A	I	X	A	A
M	C	B	E	X	I	G	A	B	R
E	A	Y	N	V	Y	L	Ç	D	O
I	R	P	X	E	R	I	F	E	P
X	A	L	E	C	O	X	O	T	E
A	L	U	X	O	X	O	P	X	Z
Q	R	S	É	X	O	Ã	Q	U	H
U	Q	Ó	U	A	V	N	R	X	W
T	M	A	X	I	X	E	H	A	Z

AMEIXA	XAROPE	XOTE	PEIXE
CAIXA	XALE	COXA	ROXO
XÍCARA	LUXO	XEXÉU	XUXA
LIXO	BEXIGA	MAXIXE	XERIFE

a q u b A c s z m x N O p c g V

AUTODITADO.

A 3D rectangular box with a slanted top and bottom edge. Inside the box, there are two columns of horizontal lines for writing, each containing six lines.

C b v H a B q A C u z m O X

a q u b A C S Z m X N O P C G V

É HORA DO DITADO.

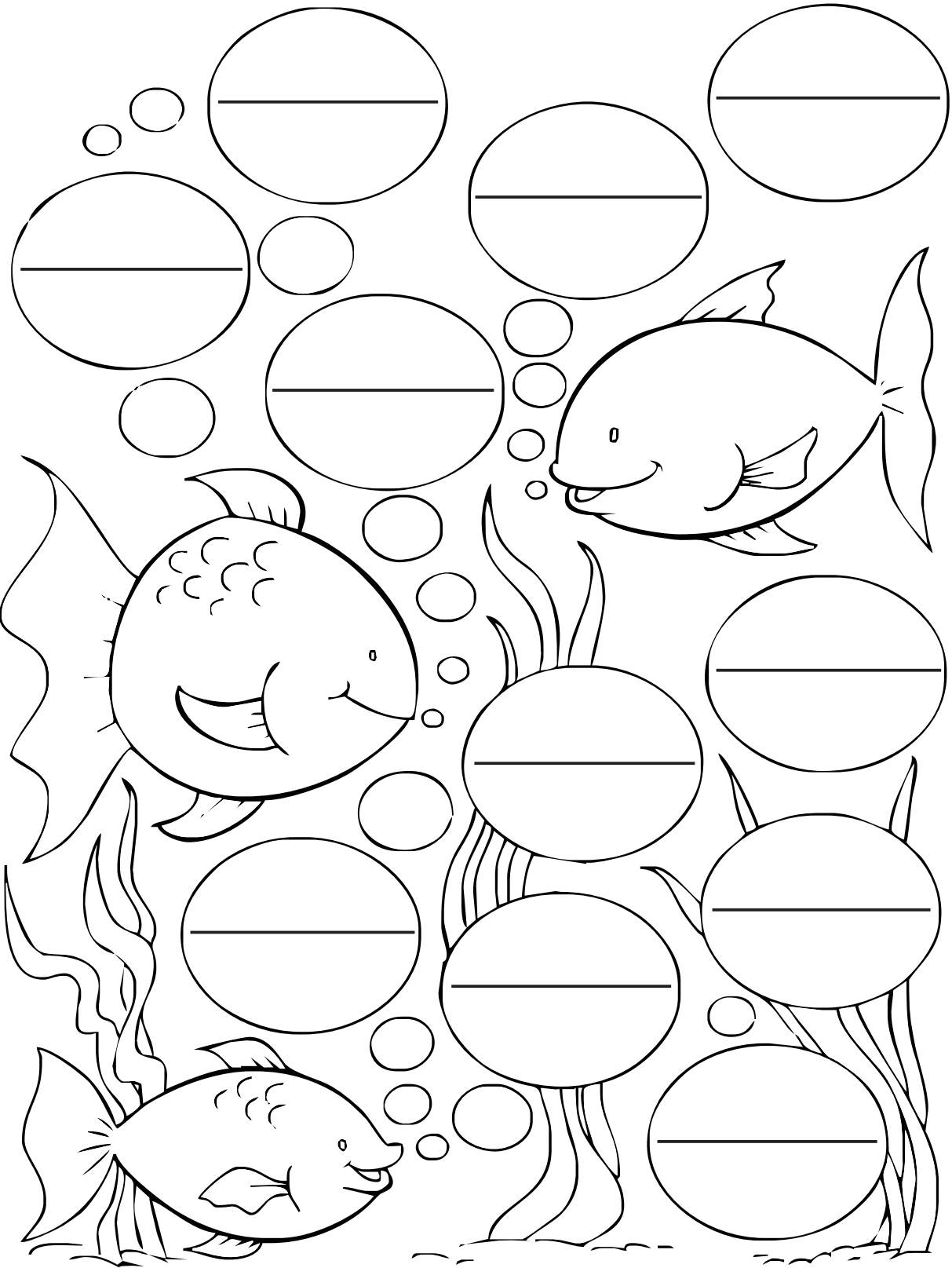

C b v H A B q A C u z m O X

PEZINHO

AI BOTA AQUI, AI BOTA ALI,
O TEU PEZINHO.
O TEU PEZINHO BEM JUNTINHO COM O MEU.
AI BOTA AQUI, AI BOTA ALI,
O TEU PEZINHO.
O TEU PEZINHO, O TEU PEZINHO,
AO PÉ DO MEU.
E DEPOIS NÃO VÁ DIZER, } BIS
QUE VOCÊ JÁ ME ESQUECEU. }
E NO CHEGAR DESSE TEU CORPO, }
UM ABRAÇO QUERO EU. } BIS
AGORA QUE ESTAMOS JUNTINHOS,
DÁ CÁ UM ABRAÇO E UM BEIJINHO. } BIS

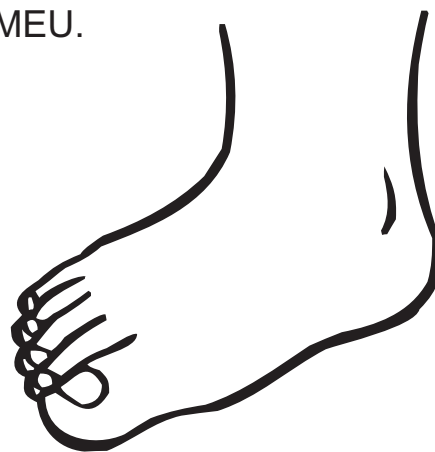

Domínio Público

COPIE A PALAVRA.

pezinho -

pezinho

Z -

z -

Z -

z -

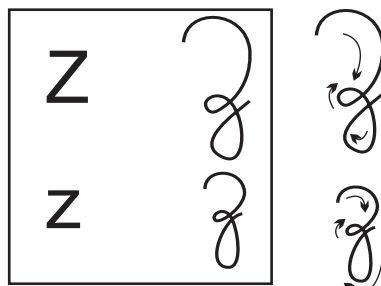
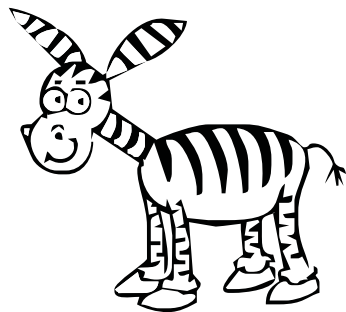

JUNTE A LETRA **Z - z** COM AS VOGAIS E FORME A FAMÍLIA SILÁBICA.

+	A	E	I	O	U
Z					

COPIE.

ZA - ZE - ZI - ZO - ZU

za - ze - zi - zo - zu

+	a	e	i	o	u	ão
z						

za - ze - zi - zo - zu - zão

za - ze - zi - zo - zu - zão

LEIA AS PALAVRAS E DEPOIS COPIE-AS NOS QUADROS, DE ACORDO COM A SÍLABA INDICADA.

AMIZADE	DEZENA	ZONA	ZENAIDE
AZEDO	BALIZA	AZULEJO	ZEZÉ
AZIA	ZUNIDO	BATIZADO	ALAZÃO
AMAZONA	BUZINA	GOZADO	COZINHA
ZUZA	JUÍZO	ZIZI	AZULÃO

ZA	ZE	ZI

ZO	ZU	ZÃO

LIGUE AS SÍLABAS E ESCREVA AS PALAVRAS.

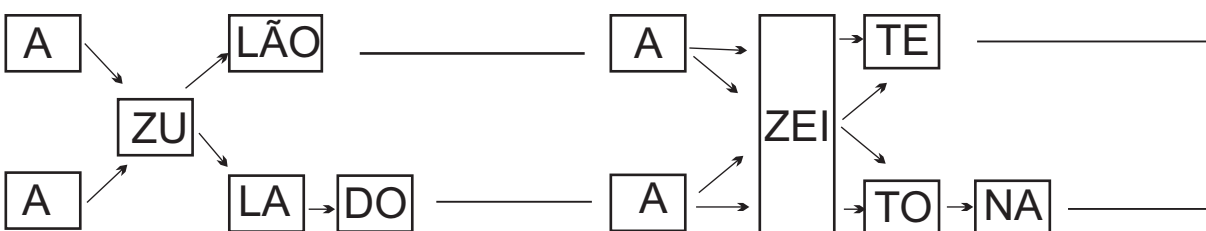
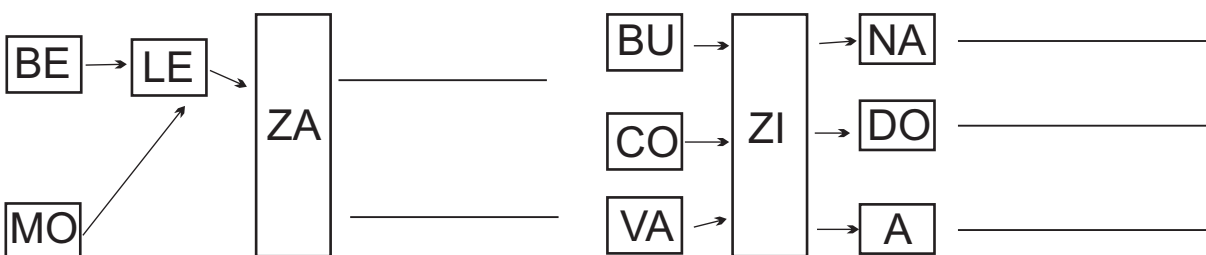

DE ACORDO COM O DESENHO, PINTE AS SÍLABAS QUE FORMAM AS PALAVRAS, E DEPOIS COPIE-AS.

19

DE ZE ZO NO VE

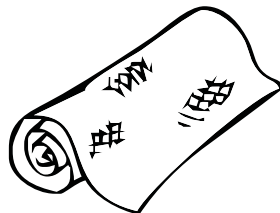

ZA GA ZE

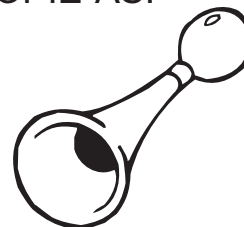

BU ZI ZU NA



A ZEI ZA TO NA

DZ.

DU ZE ZIA

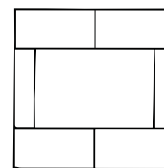

A ZI ZU LE JO

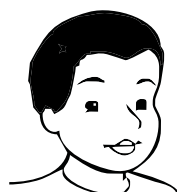

ZU ZE ZI CA

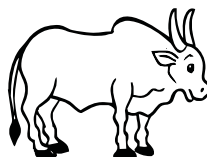

SE ZE ZA BU



A ZEI FE TE

FORME PALAVRAS COM AS SÍLABAS QUE ESTÃO CIRCULADAS. DEPOIS ESCREVA E SEPRE-AS EM SÍLABAS.

DEZESSETE

DOZE

ZONA

MOLEZA

LEVEZA

GOZADO

BELEZA

AZULEJO

AMIZADE

ZEBU

ZICO

AZEITONA

AZEITE

DEZENA

COZIDO

PINTE AS SÍLABAS QUE PERTENCEM À FAMÍLIA DA LETRA **Z-z** NAS PALAVRAS ESCRITAS NOS AZULEJOS. ESCOLHA UMA EM CADA GRUPO E ESCREVA NA LINHA INDICADA.

ZAZÁ AZALÉIA REZA AMIZADE BALIZA BATIZADO	DEZESSETE AZEITE DEZENA ZELO ZEZÉ GAZE DOZE ZECA	COZIDO BUZINA VAZIO DÚZIA ZIZI
_____	_____	_____

ZONA DEZOITO ZOADA JUÍZO	AZUL ZULU AZULEJO AZULÃO
_____	_____

ALAZÃO PEZÃO

NUMERE OS DESENHOS DE ACORDO COM AS PALAVRAS.

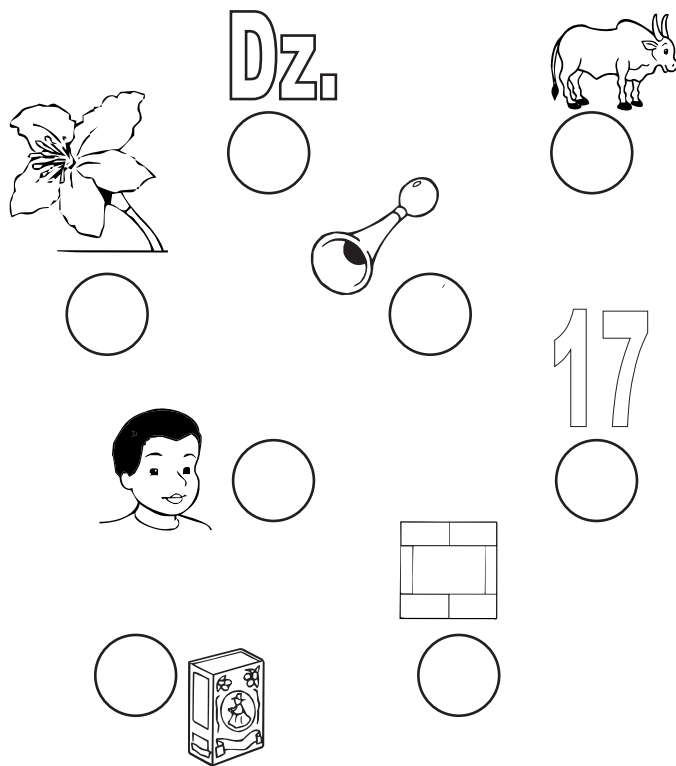

1 - ZECA
2 - ZEBU
3 - BUZINA
4 - DÚZIA
5 - DEZESSETE
6 - AZALÉIA
7 - AZEITE
8 - AZULEJO

LIGUE OS DESENHOS ÀS SÍLABAS CORRESPONDENTES.

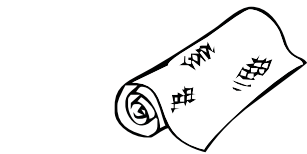

ZA

ZI

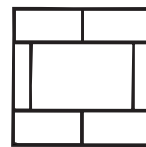

ZE



ZE

ZA

Dz.

ZU

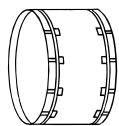

ZI

ZE

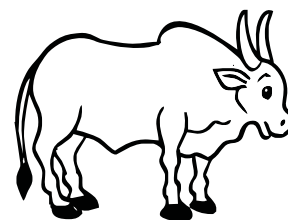

LIGUE OS NOMES AOS DESENHOS CORRESPONDENTES.
DEPOIS, ESCREVA AS PALAVRAS.

ZEBU

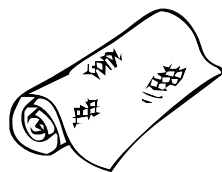

ZEBRA

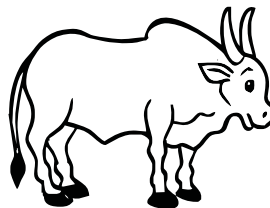
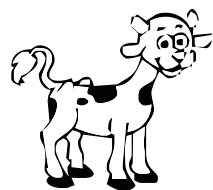

AZEITONA

GAZE

AZEITE

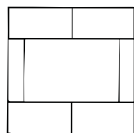

AZULEJO



BEZERRO

COMPLETE AS PALAVRAS COM AS SÍLABAS ABAIXO.

ZA

ZE

ZI

ZO

ZU

12

DO _____



BU _____ NA

DZ.

DÚ _____ A



_____ BRA

19

DE _____ NOVE

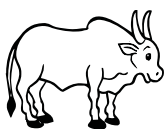

_____ BU

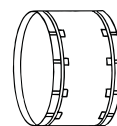

17

DE _____ SSETE

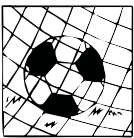
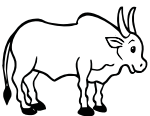

_____ BUMBA

CIRCULE AS PALAVRAS DE ACORDO COM OS DESENHOS.

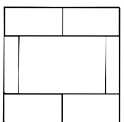
	ZAGA	MOLEZA	BATIZADO	GOZADO
	AZEDO	AZEITE	DEZENA	ZEBU
	AZIA	DÚZIA	BUZINA	ZILÁ
	JUÍZO	ZONA	ZOADA	ZOOLÓGICO
	AZUL	AZULEJO	CAZUZA	ZULU

COMPLETE AS PALAVRAS ABAIXO, COM AS SÍLABAS QUE PERTENCEM À FAMÍLIA DA LETRA **Z - z**.

____ BU A ____ DO BU ____ NA A ____ LEJO ____ CO	MOLE ____ A ____ ITONA DE ____ NOVE GO ____ DO ____ CA	AMI ____ DE A ____ ITE DÚ ____ A ALA ____ BO ____	A ____ LÉA BALI ____ BATI ____ DO DE ____ NA ____ ZÉ
--	--	---	--

ESCOLHA CINCO PALAVRAS DO QUADRO, ESCREVA NAS FICHAS E FORME FRASES.

LEIA AS PALAVRAS DA FICHA E, DEPOIS, ESCREVA-AS COMPLETANDO AS FRASES.

BOZO – BUZINA- AZEITE – AZUL – DEZESSETE

MAMÃE TEMPEROU A SALADA COM _____.

A _____ DO CARRO PIFOU.

_____ FOI O NOME DE UM PALHAÇO GOZADO.

HOJE O CÉU ESTÁ _____.

ZECA FEZ _____ ANOS.

SEPARE AS PALAVRAS EM SÍLABAS E LIGUE-AS
INDICANDO O NÚMERO DE SÍLABAS DE CADA UMA.

ZEBU

ZOOLÓGICO

2

ZELO

3

BELEZA

ZERO

4

BATIZADO

AZEDO

5

SUBSTITUA OS DESENHOS PELAS PALAVRAS
E ESCREVA AS FRASES.

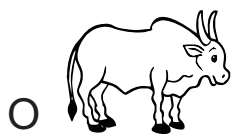

O  PULOU, PULOU E O PEÃO CAIU NO CHÃO.

A MAMÃE FEZ SALADA DE TOMATE COM



ZENAIDE COMPROU UMA **DZ.** DE OVOS.

A



TOCA MUITO ALTO.

ORDENE AS PALAVRAS E COPIE AS FRASES.

AZULEJISTA. 5

ZICO 1

É 2

BOM 4

UM 3

ZULU 1

SALADA.

GOSTA 2

DE 3

NA 5

AZEITE 4

CARRO. 6

DO 5

A 3

ZECA 1

TOCOU 2

BUZINA 4

NO 5

ZEBRA 4

VIU 2

ZIZI 1

A 3

ZOOLOGICO. 6

JUNTE AS SÍLABAS DO DESENHO DE ACORDO COM OS NÚMEROS E ESCREVA AS PALAVRAS.

5 - 10 - 9 - 16

6 - 7

6 - 8

5 - 12 - 2 - 15

6 - 14

5 - 4 - 5



5 - 10 - 13

5 - 6 - 11

1 - 6

6 - 6

6 - 3

3 - 4 - 16

FAÇA UM X NAS PALAVRAS QUE SEPARANDO-AS REPRESENTAM OS NOMES DOS DESENHOS. DEPOIS, COPIE-AS NOS QUADROS SEPARADO-AS EM SÍLABAS.



AZEITE
 AZUL
 AZEDO



ZIZI
 BUZINA
 BEZENA

--	--	--

--	--	--

--	--	--

DÚZIA
 DEZENA **Dz.**
 DEZESSETE

ZECA
 ZEBRA
 ZEBU

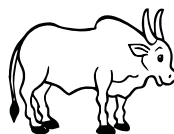

DEZENOVE
 DEZESSEIS
 DOZE

12

--	--

--	--

--	--

ESCREVA NO DOMINOX O NOME DOS NUMERAIS.

12	14
17	
19	13
15	
16	11
18	

D	E	Z	E	S	S	E	T	E

LEIA E NUMERE OS DESENHOS,
DE ACORDO COM AS PALAVRAS.

1 - ZEBU

2 - AZEITE

3 - PEZINHO

4 - DEZOITO

5 - DEZESSEIS



18



12

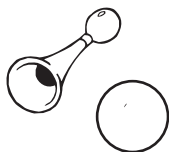

16

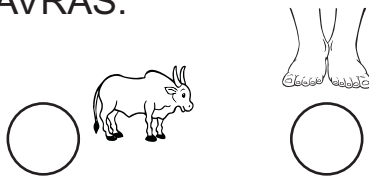

19



6 - BUZINA

7 - ZEBRA

8 - AZEITONA

9 - DEZENOVE

10 - DOZE

SEPARE AS PALAVRAS NA COLUNA CORRESPONDENTE.

S	<hr/> <hr/> <hr/> <hr/> <hr/> <hr/> <hr/> <hr/>
---	---

<p>CASA AVISO BUZINA AZIA LISO ROSA DOZE AZUL CAMISETA CASACO ZEBU ZOADA AZULÃO MESA ZEBRA</p>
--

Z	<hr/> <hr/> <hr/> <hr/> <hr/> <hr/> <hr/> <hr/>
---	---

LEIA AS PALAVRAS, ESCOLHA UMA EM CADA QUADRO, COPIE E SEPARE-A EM SÍLABAS.

BUZINA
BÚZIO
ZICO
COZIDO

AZEDO
DOZE
ZEBU
ZECA

AZUL
AZULÃO
ZUZA
AZULADO

ZAZÁ
AMIZADE
MOLEZA
GOZADO

ZOOLÓGICO
ZOADA
DEZOITO
JUÍZO

COMPLETE AS FRASES COM UMA DAS PALAVRAS DAS FICHAS.

_____ FOI AO JARDIM ZOOLOGICO PASSEAR.

ZOÉ - DEZENOVE - DOZE

LÁ, ELA VIU O PÁSSARO _____.

ZEBRA - AZULÃO - BUZINA

ELA FEZ _____ COM ZECA E ZAZÁ.

AMIZADE - DEZENOVE - REZA

A MENINA QUER VOLTAR NO JARDIM _____.

BUZINA - ZOOLOGICO - AZUL

RECORTE DE JORNAIS E REVISTAS PALAVRAS QUE TENHAM
SÍLABAS DAS LETRAS **X E Z** E COLE-AS NO ESPAÇO INDICADO.

X-x

Z-z

CAÇA-PALAVRAS.

W	A	Y	N	R	V	Q	X	G	K	M
A	Z	E	B	R	A	D	Y	H	L	N
Z	E	B	U	M	W	E	D	O	Z	E
E	D	A	Z	U	L	N	E	L	Ô	P
I	O	K	I	S	A	E	D	F	O	Q
T	S	V	N	B	C	N	R	S	T	U
O	X	D	A	I	M	O	L	E	Z	A
N	B	Ú	R	J	V	V	X	W	E	Y
A	A	Z	E	I	T	E	K	Q	C	K
A	M	I	Z	A	D	E	H	I	A	J
C	D	A	A	A	B	C	Z	E	L	O

ZÔO	ZEBRA	DEZENOVE	ZEBU
BUZINA	ZELO	AZUL	REZA
DÚZIA	AZEITONA	DOZE	AMIZADE
MOLEZA	ZECA	AZEDO	AZEITE

a q u b A C S z m X N O p c G V

p
c
z
o
g
s
a
s
u
D
q
N
G
C
h

g
a
s
u
q
h
z
s
p
r
D
A
m
O
V
p
N

AUTODITADO.

ESCREVA AS PALAVRAS QUE TENHAM
SÍLABAS COM A FAMÍLIA DA LETRA **Z - z**.

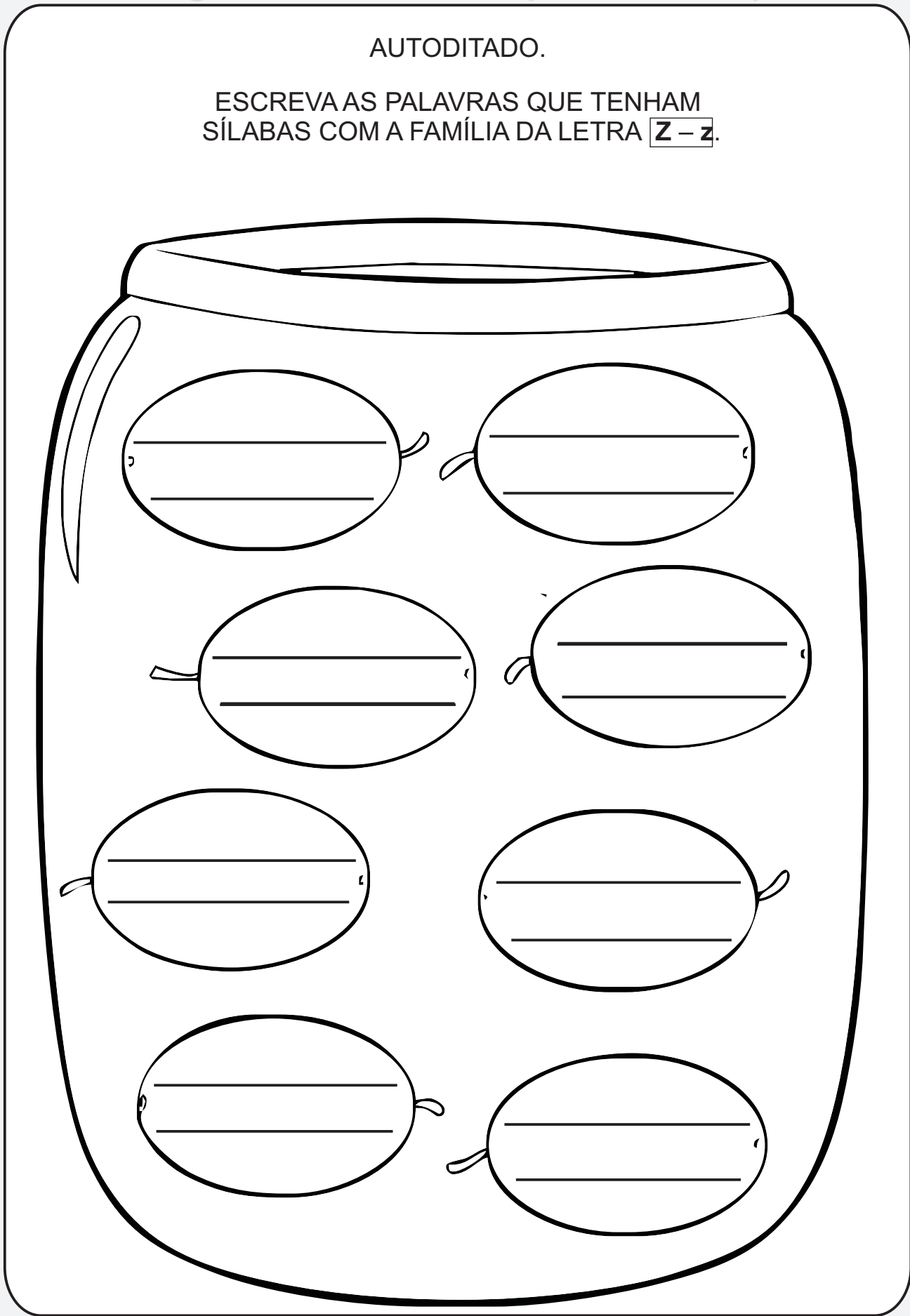

C b v H a B q A C u z m O X

a q u b A C S z m X N O p c G V











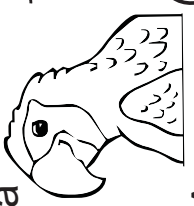









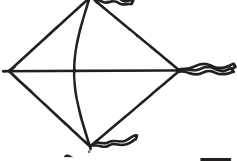
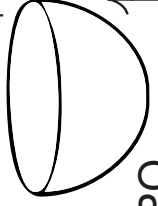
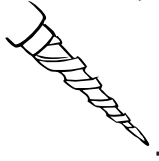

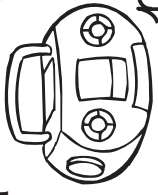

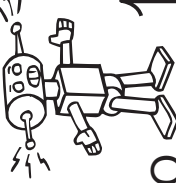
HORA DO DITADO.

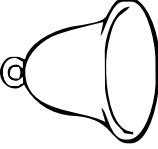

_____		_____	
_____	_____	_____	_____
_____		_____	
_____	_____	_____	_____
_____		_____	
_____	_____	_____	_____

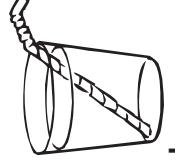
C b v H a B q A C u z m O X

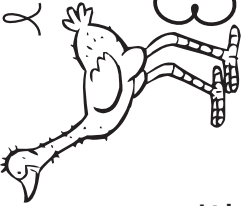
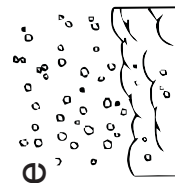
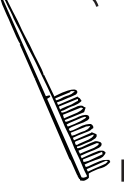
NA	PA	RA	SA	A
NE	PE	RE	SE	E
NI	PI	RI	SI	I
NO	PO	RO	SO	O
NU	PU	RU	SU	U
NÃO	PÃO	RÃO	SÃO	ÃO
NA	PA	RA	SA	A
NE	PE	RE	SE	E
NI	PI	RI	SI	I
NO	PO	RO	SO	O
NU	PU	RU	SU	U
NÃO	PÃO	RÃO	SÃO	ÃO

TA	VA	XA	ZA	A
TE	VE	XE	ZE	E
TI	VI	XI	ZI	I
TO	VO	XO	ZO	O
TU	VU	XU	ZU	U
TÃO	VÃO	XÃO	ZÃO	ÃO
TA	VA	XA	ZA	A
TE	VE	XE	ZE	E
TI	VI	XI	ZI	I
TO	VO	XO	ZO	O
TU	VU	XU	ZU	U
TÃO	VÃO	XÃO	ZÃO	ÃO

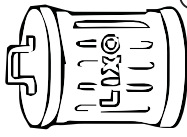
a		A	i		I	o		O	u		U	ã		ÃO
na		NA	ni		NI	no		NO	nu		NU	não		NÃO
pa		PA	pi		PI	po		PO	pu		PU	pão		PÃO
ra		RA	ri		RI	ro		RO	ru		RU	rão		RÃO
sa		SA	si		SI	so		SO	su		SU	são		SÃO
e		E	ne		NE	pe		PE	re		RE	se		SE

ta  TA	ta  TE	ti  TI	to  TO	tu  TU	tāo  TĀO
va  VA	ve  VE	vi  VI	vo  VO	vū  VU	vāo  VĀO
xa  XA	xe  XE	xi  XI	xo  XO	xu  XU	xāo  XĀO
za  ZA	ze  ZE	zi  ZI	zo  ZO	zu  ZU	zāo  ZĀO
a  A	e  E	i  I	o  O	u  U	āo  ĀO