

A coleção “CIRANDA DAS SÍLABAS” é composta por seis volumes, organizados em lições que apresentam atividades seqüenciais. Nos volumes 1 e 2, as lições envolvem o trabalho com vogais e consoantes, facilitando o aprendizado do alfabeto. Os demais volumes estão voltados à sistematização das famílias silábicas, permitindo, dessa maneira, que o professor avalie sistematicamente os avanços de seus alunos, fazendo intervenções adequadas ao perceber que algum aluno não está aprendendo de forma satisfatória.

Ruth Rozendo Caputo

ISBN 978853800010-5



9 788538 000105



Ciranda Cultural
www.cirandacultural.com.br

CIRANDA DAS



Ciranda Cultural

Volume 3

CAI, CAI, BALÃO

CAI, CAI, BALÃO
CAI, CAI, BALÃO
AQUI NA MINHA MÃO.
NÃO CAI NÃO
NÃO CAI NÃO
NÃO CAI NÃO
CAI NA RUA DO SABÃO.

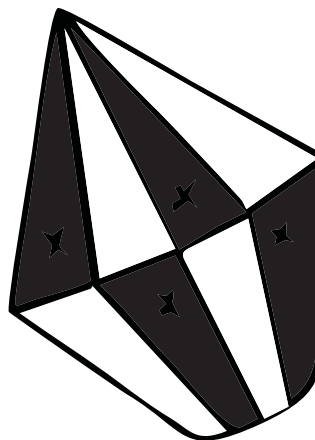

As Mais Belas Cantigas de Roda, Ed. Ciranda Cultural, pág.5.

CIRCULE A PALAVRA **BALÃO** NO TEXTO ACIMA.

COPIE A PALAVRA BALÃO.

BALÃO -

balão

balão

B

B

b

b

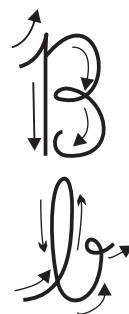
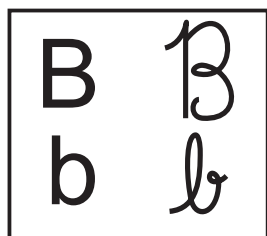
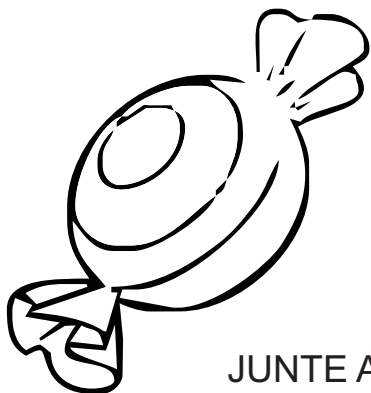

JUNTE A LETRA **B-b** COM AS VOGAIS
E FORME A FAMÍLIA SILÁBICA.

+	A	E	I	O	U
B					

COPIE.

BA - BE - BI - BO - BU

Bo - Be - Bi - Bo - Bu

+	a	e	i	o	u	ão
b						

ba - be - bi - bo - bu - bão

ba - be - bi - bo - bu - bão

PINTE A LETRA **B-b** NAS PALAVRAS DO QUADRO.



Beatriz	bebê	BomBril	aba
batata	Brenda	Bruno	Becel
abóbora	Bianca	BIS	bule
Barbie	baú	BRASIL	bico
cabo	boneca	oba	BIC

JUNTE A LETRA **B-b** COM AS VOGAIS, FORME A FAMÍLIA SILÁBICA E COPIE-AS.

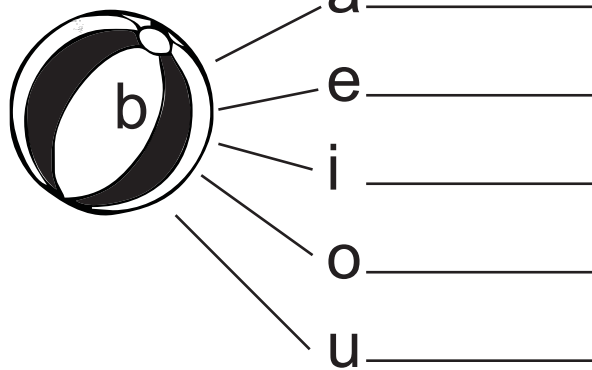
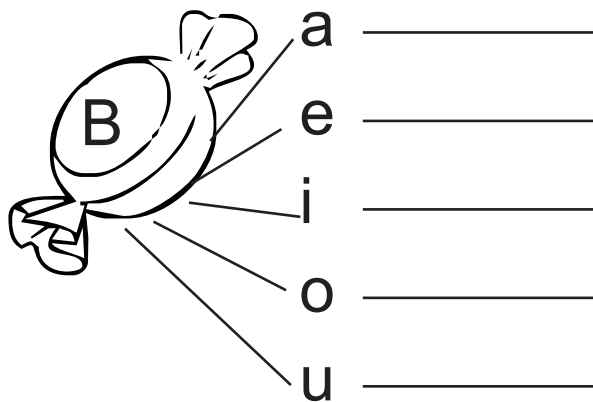

Ba - Be - Bi - Bo - Bu

Blank handwriting practice lines.

ba - be - bi - bo - bu

Blank handwriting practice lines.

PINTE SOMENTE OS DESENHOS
QUE INICIAM COM A MESMA SÍLABA.



PINTE OS DESENHOS QUE
COMEÇAM COM A MESMA SÍLABA.

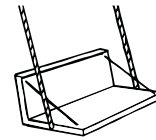
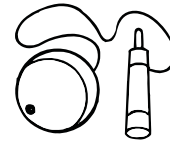
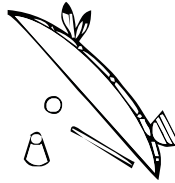
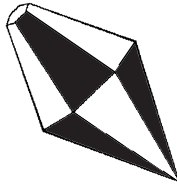
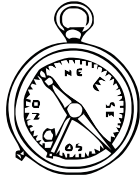
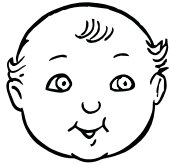
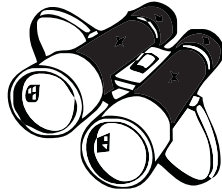
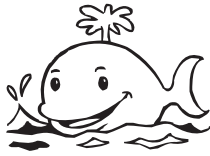

JUNTE AS SÍLABAS E FORME PALAVRAS.

+	A	E	I	O	U
B	BA	BE	BI	BO	BU

EXEMPLO:
O + BA = OBA

JUNTE AS SÍLABAS NO QUADRO ABAIXO
E ESCREVA AS PALAVRAS FORMADAS.

+	BA	BE	BI	BO	BÃO
BA					
BE					
BI					
BO					

ESCREVA AS SÍLABAS QUE
FALTAM NOS NOMES DOS DESENHOS.

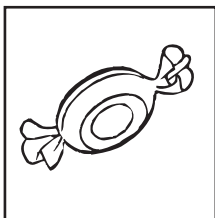

___LA

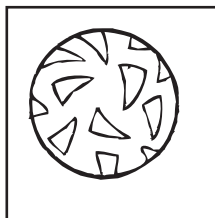

___LA

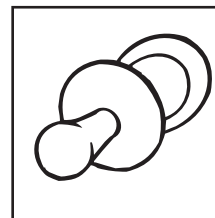

___CO

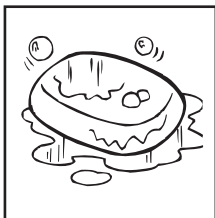

SA ___ NETE

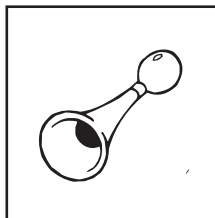

___ZINA

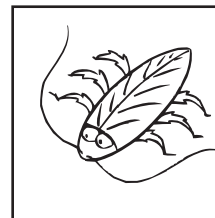

___RATA

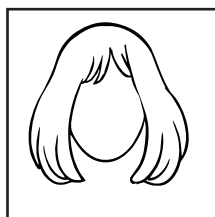

CA ___ LO

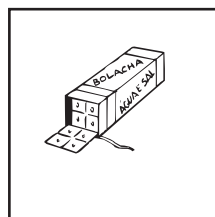

___LACHA

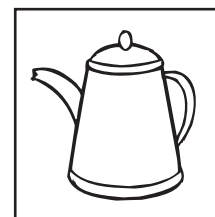

___LE

OBSERVE O QUADRO E JUNTE AS SÍLABAS FORMANDO PALAVRAS.

BA	BE	BI	BO	BU	BÃO
----	----	----	----	----	-----

BA _____ BA _____ BA _____
 BE _____ BE _____ BE _____
 BO _____ BO _____ BI _____
 BU _____ BO _____ BI _____

COMPLETE A SÍLABA QUE ESTÁ FALTANDO.

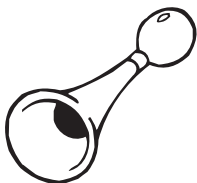

____ZINA

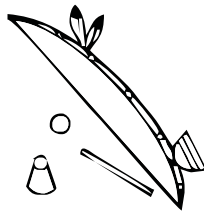

____RIMBAU

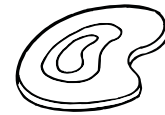

____FE



____LA

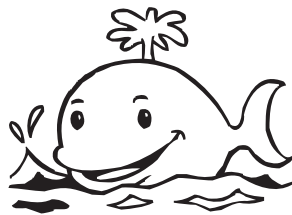

____LEIA

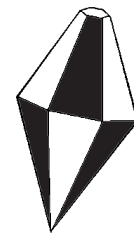

____LÃO



____LO



SA____

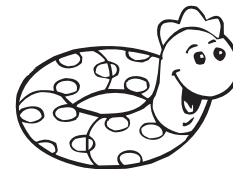

____IA

DESCUBRA AS PALAVRAS ESCONDIDAS
NO QUADRO, JUNTANDO AS SÍLABAS

A 1	BI 2	BO 3
BE 4	I 5	O 6
IA 7	BA 8	U 9
BÃO 10	BÊ 11	BÁ 12

- 1+8 _____ 3+1 _____
 2+1 _____ 3+5 _____
 3+4 _____ 3+7 _____
 3+8 _____ 4+3 _____
 4+2 _____ 4+11 _____
 9+12 _____ 6+8 _____
 8+10 _____ 4+2+1 _____
 8+12 _____ 3+10 _____

ESCREVA O NOME DOS DESENHOS.

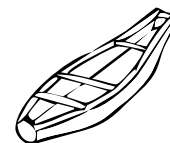
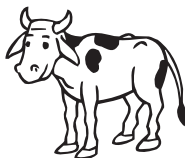
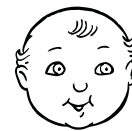
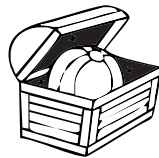
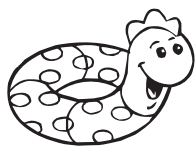

ADIVINHE.
QUAL É O BANHO QUE SE TOMA E NÃO FICA MOLHADO?
(BANHO DE SOL)

COMPLETE COM **b** OU **B**.

___ola ___ia ___oba ___aía
___runo ___óia ___omBril a___iu
___ebê ___eatriz ___ule a___acaxi
___alão ___aú u___á a___acate

COMPLETE O QUADRO COM
SÍLABAS DA FAMÍLIA DA LETRA **b-B**.

u___	o___	___a
___bão	ba___	a___
be___	bo___	___bi
___i	___beu	___bá
___bê	___le	___bá

AGORA, ESCREVA AS PALAVRAS QUE VOCÊ FORMOU.

DESENHE NA CESTA, FRUTAS CUJOS
NOMES TENHAM A LETRA **B**. ESCREVA AO
LADO O NOME DE CADA FRUTA DESENHADA.



LIGUE ABAIXO AS PALAVRAS E
SÍLABAS CORRESPONDENTES.

aba	bo	ba	ABA
bebê	u	bá	BEBÊ
boba	a	ba	BOBA
bebi	Bi	a	BEBI
ubá	be	bê	UBÁ
Bia	be	bi	BIA

a q u b A C S z m X N O p c G V

JUNTE AS SÍLABAS E FORME PALAVRAS.

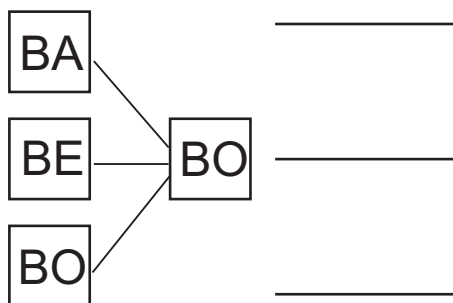
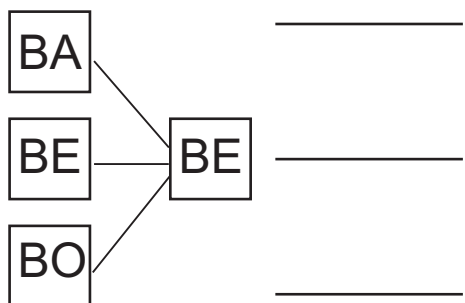
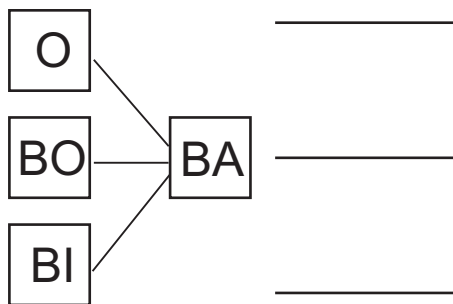
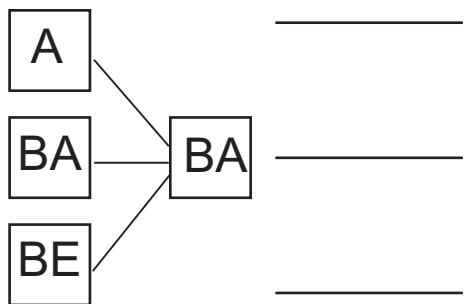

DESCUBRA AS PALAVRAS ESCONDIDAS JUNTANDO AS SÍLABAS DO DESENHO.

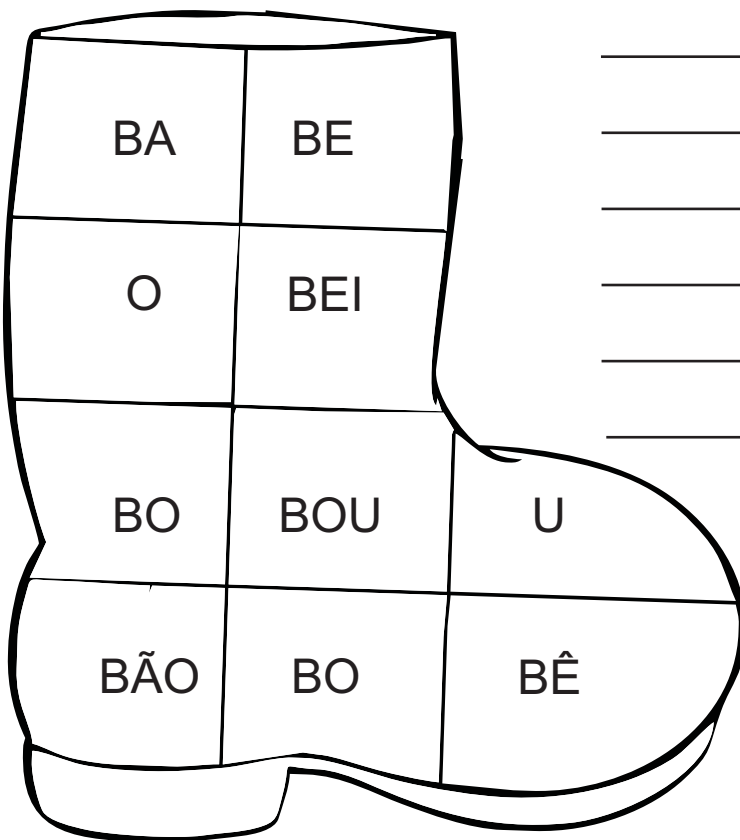

C b v H a B q A C u z m O X

JUNTE AS SÍLABAS DOS BALÕES E FORME PALAVRAS.

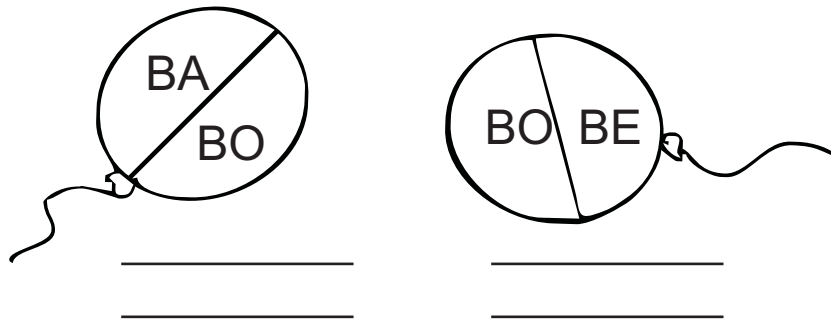
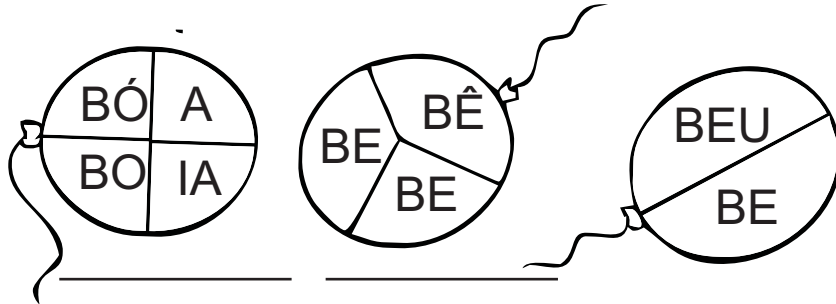

JUNTE AS SÍLABAS DE ACORDO COM AS FIGURAS E FORME PALAVRAS.

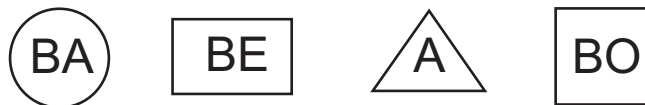

○ + □	_____	○ + □	_____
□ + ○	_____	□ + □	_____
△ + ○	_____	□ + ○	_____
□ + □	_____	□ + △	_____

SEPARE AS SÍLABAS DAS PALAVRAS.

BOBA	□	□	BABO	□	□
BOA	□	□	UBÁ	□	□
BOBÃO	□	□	BEBO	□	□
ABA	□	□	BEBEU	□	□

PINTE AS SÍLABAS QUE
CORRESPONDEM AOS NOMES DOS DESENHOS.

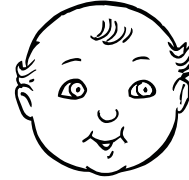
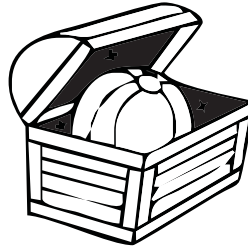

BA

BI

BE

BÁ

BE

BA

BU

Ú

BE

BO

BÊ

BU

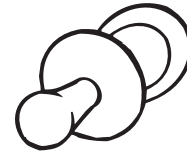

BO

BA

LA

BU

A

BU

BO

LE

BU

BI

CO

CA

PINTE AS SÍLABAS NAS PALAVRAS DO QUADRO
USANDO COR DIFERENTE PARA CADA SÍLABA.

BA	BE	BI	BO	BU
----	----	----	----	----

BALA	BEBIDA	BODE	BULE
BOLA	BANANA	BIFE	CABELO
BELO	BUZINA	BAÚ	CABIDE
BOCA	BICO	BÚZIO	BOBA
ABIU	ABACATE	BECA	BOTA

FORME PALAVRAS JUNTANDO AS SÍLABAS QUE ESTÃO EM DESTAQUE.

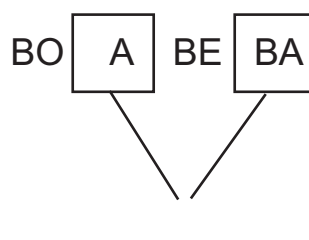
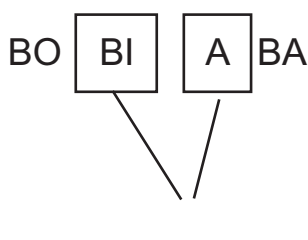
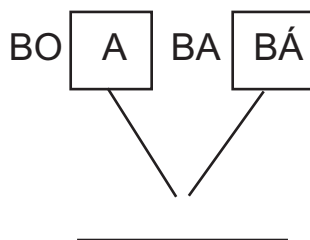
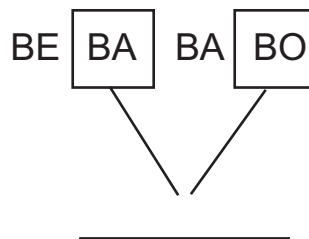
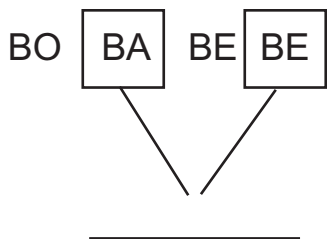

PINTE AS SÍLABAS INDICADAS NAS PALAVRAS ABAIXO.

BALA

BOBA BAÚ CABANA ABA BALÃO

BEBA

BELA CABELO BOBE BECO BEBO

BIA

BAMBI BEBIA CABIDE BIFE BICO

BOBA

CABO BONÉ BONECA BOLA LOBO







BULE

BUZINA BÚSSOLA BÚZIO ABUSO BAMBU

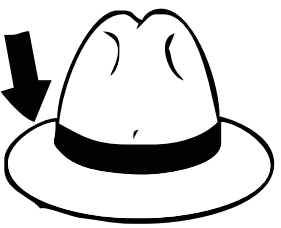
a q u b A C S Z m X N O P C G V

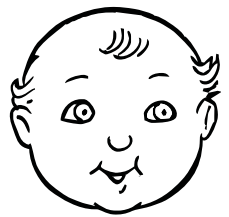
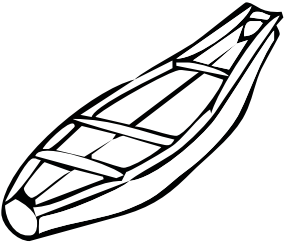
FORMANDO PALAVRAS

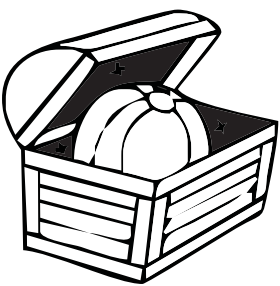
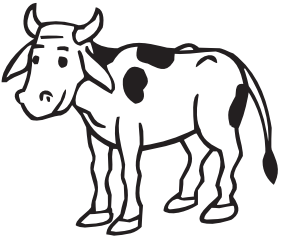
RECORTE AS SÍLABAS E COLE EMBAIXO DO DESENHO FORMANDO A PALAVRA CORRESPONDENTE.

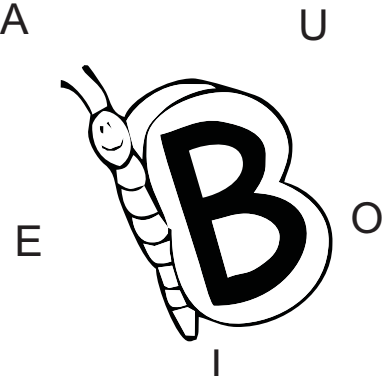
A	BI	BA	BA	BÊ	í
U	BA	BO	BE	BA	A
A	I	BÁ	BÁ	Ú	

C b v h a B q A C u z m O X

COMPLETE AS FRASES ESCRIVENDO AS PALAVRAS DO QUADRO NO LUGAR ADEQUADO.

BICO	BIA	BAÚ	BABOU	BÓIA
------	-----	-----	-------	------

O BEBÊ _____ NA BIA.

A BABÁ DO BEBÊ É A _____.

O _____ É DO BEBÊ.

BIA DEU A _____ AO BEBÊ.

NO _____ TEM BRINQUEDO.

SEPARE AS PALAVRAS EM LETRAS E SÍLABAS.



BALÃO				

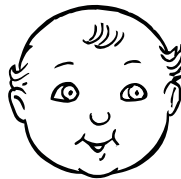

BEBÊ			

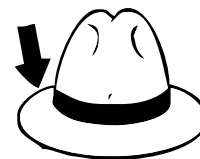

ABA		

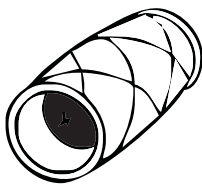

BOBE			

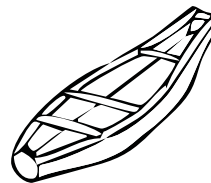

UBÁ		

LEIA AS FRASES E COPIE-AS FAZENDO
A CORRESPONDÊNCIA DE ACORDO COM O DESENHO.

O BOLO É DA BIA.

A BÓIA É DO BEBÊ.

A BOLA ESTÁ NO BAÚ.

A BALA É DE BANANA.

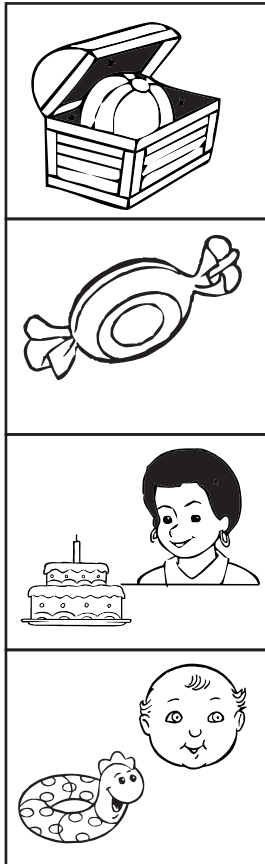

COMPLETE.

LÁ VAI A MINHA BARQUINHA CARREGADA
DE PALAVRAS COMEÇADAS COM A LETRA **B**.

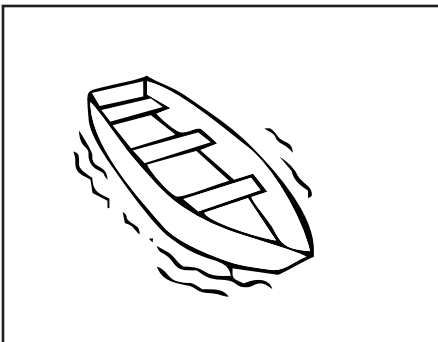

a q u b A C S Z m X N O P C G V

CAÇA - PALAVRAS

P	Q	S	T	B	O	B	E	Y
X	Z	C	F	K	L	B	M	Z
D	G	A	B	A	S	O	Z	X
B	A	I	J	B	Ó	I	A	B
A	N	R	T	O	B	A	X	I
E	O	U	Y	B	E	B	Ê	A
B	A	Ú	Z	Y	U	K	F	L
P	Q	V	W	C	B	D	J	K
W	X	B	A	B	Á	H	L	P

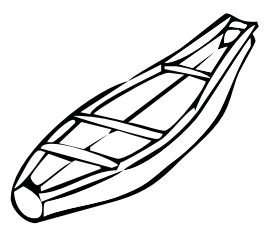
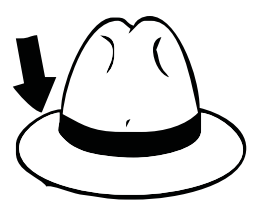
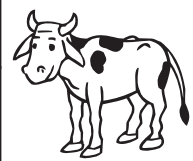
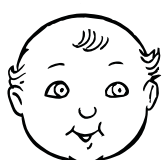
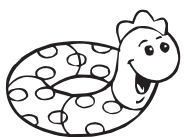

UBÁ	BEBÊ	BABÁ	BAÚ	BOBE
BOI	BÓIA	ABA	OBA	BIA

C b v H a B q A C u z m O X

a q u b A C S z m X N O p c G V

AUTODITADO

ESCREVA PALAVRAS QUE
TENHAM SÍLABAS DA FAMÍLIA DA LETRA **B**.

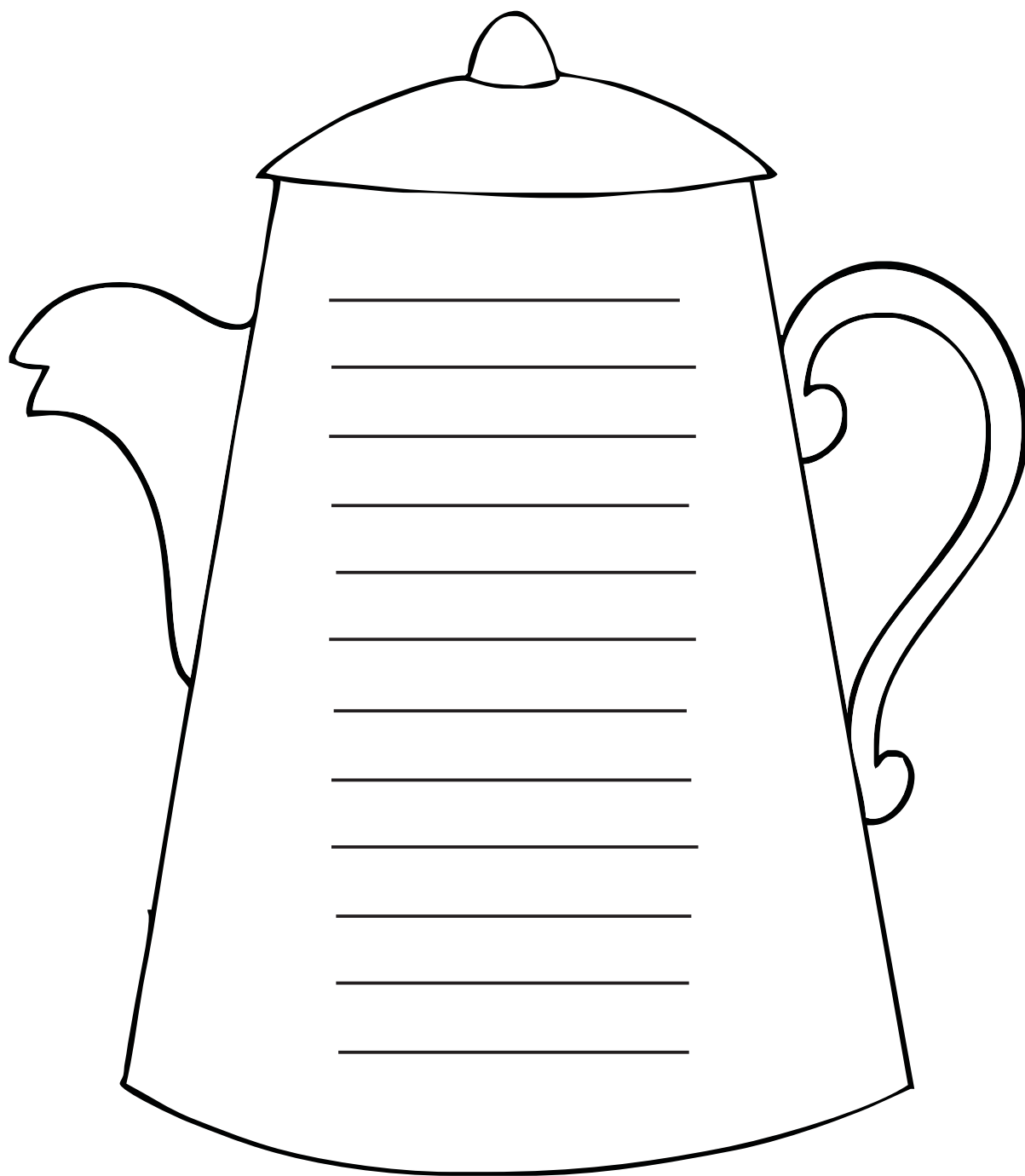

C b v H a B q A C u z m O X

a q u b A C S z m X N O p c G V

p
c
v
o
g
s
a
s
u
D
q
N
G
c
h

g
a
s
u
q
h
z
s
p
r
D
A
m
O
V
p
N

DITADO

ESCREVA COM ATENÇÃO AS PALAVRAS DO DITADO.

1 _____

2 _____

3 _____

4 _____

5 _____

6 _____

7 _____

8 _____

9 _____

10 _____

11 _____

12 _____

C b v H a B q A C u z m O X

PARLENDA

CORRE CUTIA
NA CASA DA TIA.
CORRE CIPÓ,
NA CASA DA VÓ.

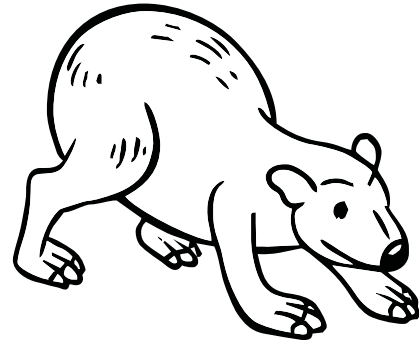

LENCINHO NA MÃO
CAIU NO CHÃO.
MOÇA BONITA
DO MEU CORAÇÃO.

Domínio Público

CIRCULE NO TEXTO ACIMA AS PALAVRAS QUE TÊM A LETRA **C**.

COPIE AS PALAVRAS.

CASA	CORAÇÃO	CUTIA
casa	coração	cutia
<i>casa</i>	<i>coração</i>	<i>cutia</i>

COPIE A LETRA **C-c**.

C - _____

C - _____

c - _____

c - _____

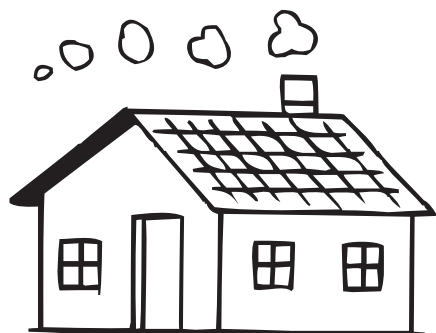

C	C
c	c



JUNTE A LETRA **C-c** COM AS VOGAIS
E FORME A FAMÍLIA SILÁBICA.

+	A	O	U
C			

COPIE AS SÍLABAS.

CA - CO - CU

--

Ca - Co - Cu

--

Ca-Co-Cu

--

+	a	o	u	ão
c				

COPIE A FAMÍLIA SILÁBICA DA LETRA **C-c**.

ca - co - cu - cão

--

Ca - Co - Cu - Cão

--

Ca-Co-Cu-Cão

--

Ca-Co-Cu

--

PINTE A LETRA **C-c** NAS PALAVRAS
 ESCRITAS NO DESENHO DA CASA.

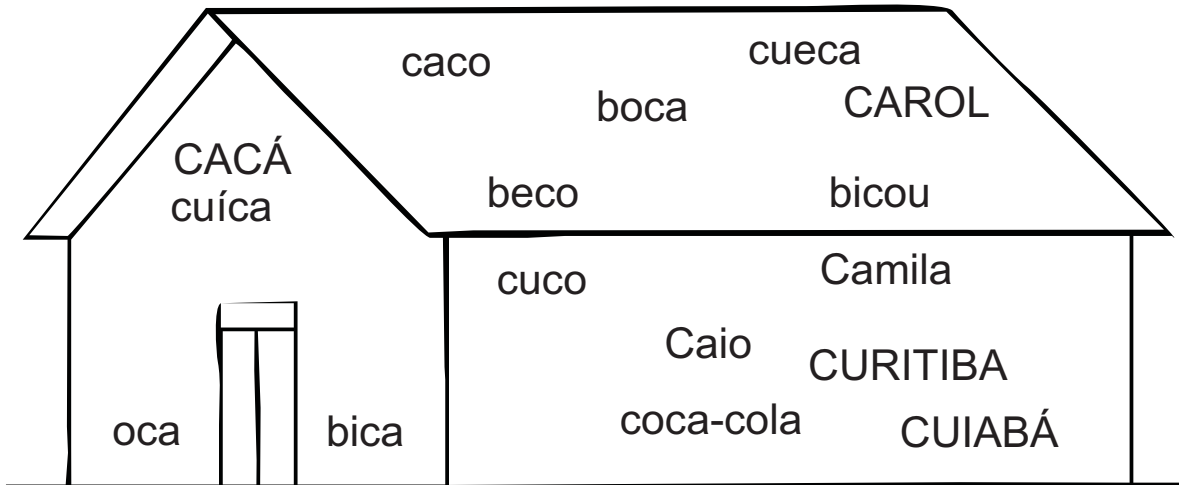

JUNTE A LETRA **C-c** COM AS
 VOGAIS E FORME A FAMÍLIA SILÁBICA.

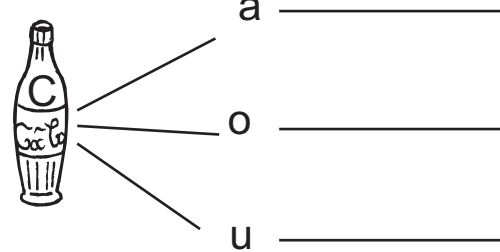
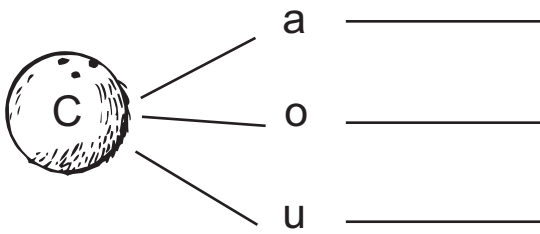

COPIE.

ca - ca

co - co

cu - cu

Ca

Co

Cu

a q u b A C S Z m X N O P C G V

PINTE SOMENTE OS DESENHOS
QUE TEM A SÍLABA **CA**.

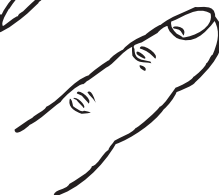
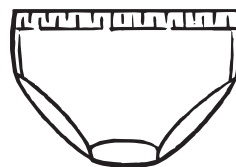
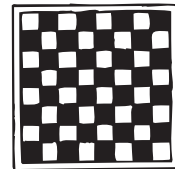
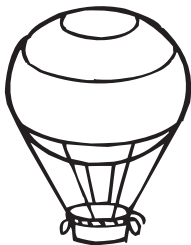
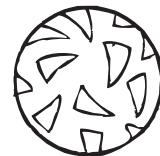
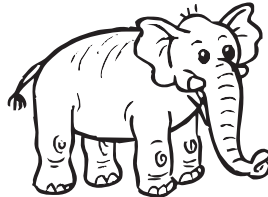
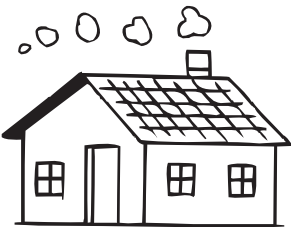
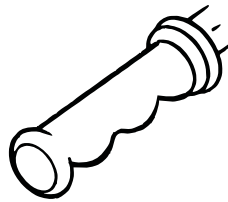
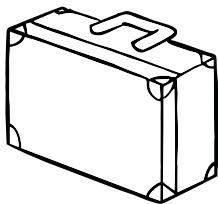
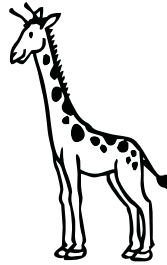
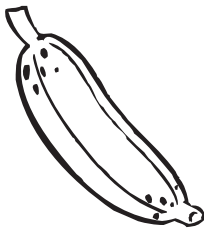
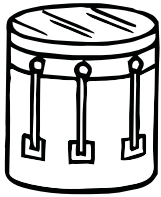
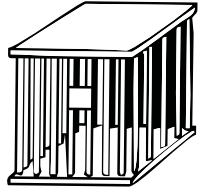

C b v H A B q A C u z m O X

PINTE OS DESENHOS QUE TENHAM NO NOME,
AS SÍLABAS **CA**, **CO**, **CU**.

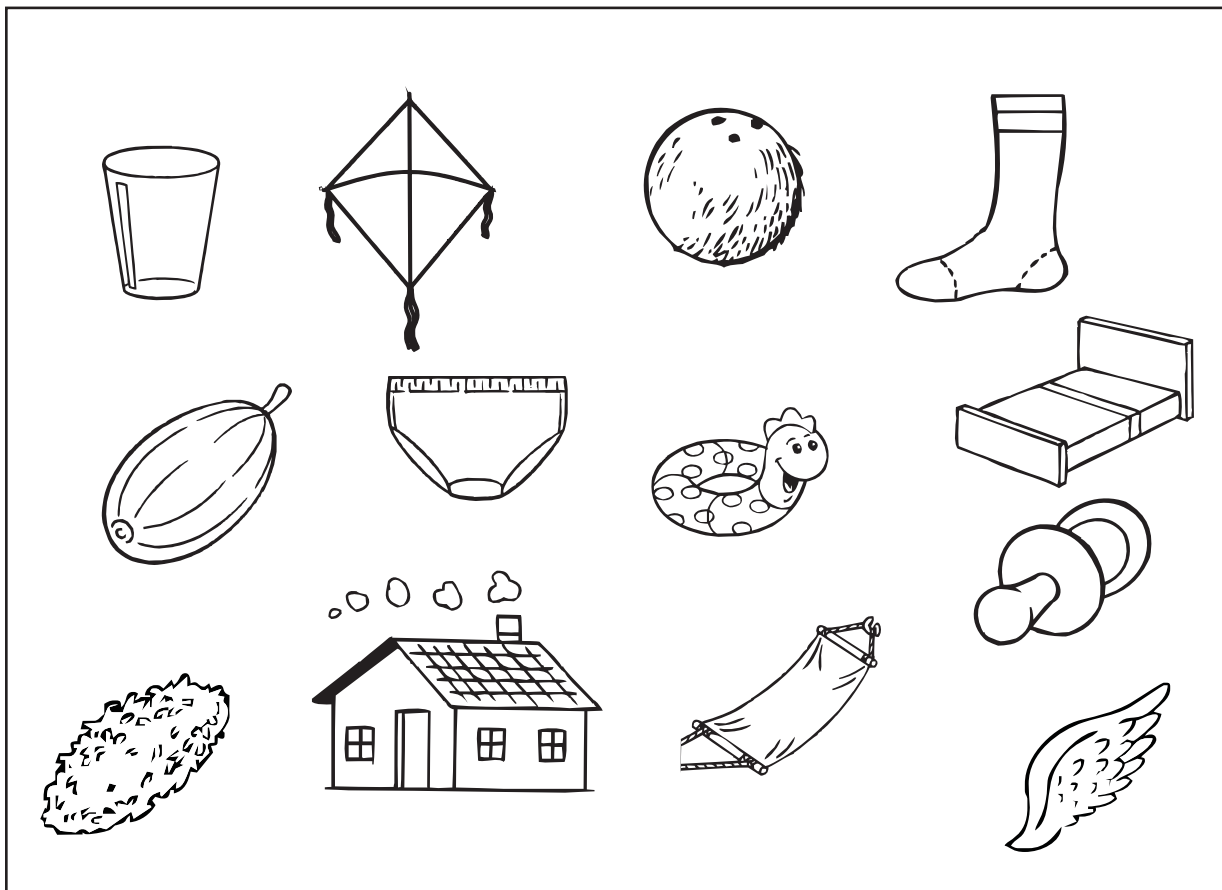

SEPARE AS PALAVRAS EM SÍLABAS.

COCA

CUECA

CUCO

CUÍCA

BICO

ACABA

ECO

COCADA





BECO



ACABOU



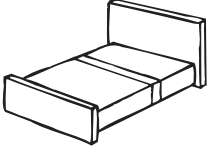
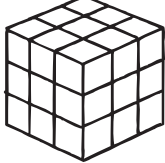

FORME PALAVRAS UNINDO AS SÍLABAS DO QUADRO.

+	CA	CO	CU	CÃO
CA				
CO				
CU				

ESCREVA AS SÍLABAS QUE FALTAM NOS NOMES DOS DESENHOS.

 __ SA	 __ PO	 O __	 __ CO
---	---	---	---

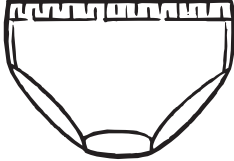
 __ MA	 __ BO	 CO __	 BI __
--	--	---	--

 CO __ DA	 CUÍ __	 __ ECA	 __ CAU
---	---	--	---

TROQUE A PRIMEIRA LETRA E
DESCUBRA OUTRAS PALAVRAS.

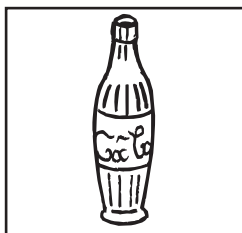

COCA
__ OCA
__ OCA
__ OCA
__ OCA

COLA
__ OLA
__ OLA
__ OLA
__ OLA

LIGUE AS PALAVRAS AO DESENHO CORRESPONDENTE.

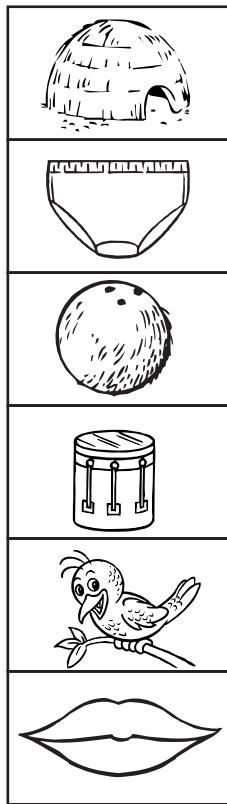

CUECA

oca

CUÍCA

cueca

OCA

cuíca

COCO

coco

BOCA

cuco

CUCO

boca

PINTE AS SÍLABAS QUE FORMAM OS NOMES DOS DESENHOS.

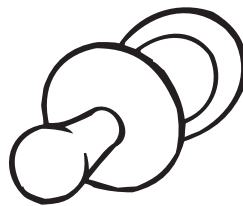

BO BE CA CU

CA BI CU CO

CO O CA CU

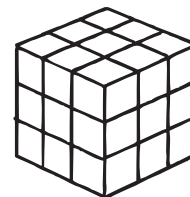
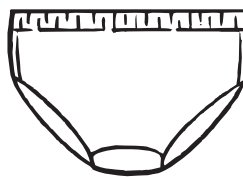

CA CU CO BO

BU CU E CA

CU CO BO CA

DESCUBRA O SEGREDO.

OCA	BULE	CUCO	COCA	BEBEU
BALA	BABÃO	BOI	CAIO	CUECA
BIA	COCADA	CABE	BOLO	CACAU

B

C

_____	_____
_____	_____
_____	_____
_____	_____

_____	_____
_____	_____
_____	_____
_____	_____

JUNTE AS SÍLABAS E FORME PALAVRAS.

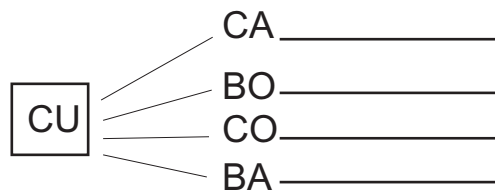
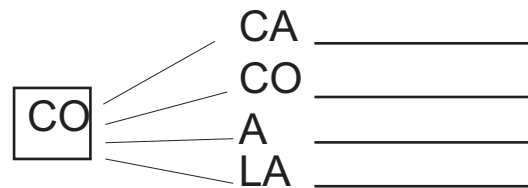
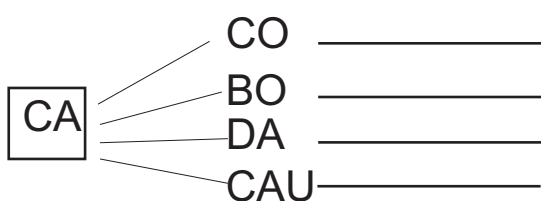

COMPLETE COM AS SÍLABAS CA, CO, CU, FORMANDO PALAVRAS.

BO _____	CUE _____	_____ CADA	_____ CA
BI _____	CU _____	_____ ÍCA	_____ BO
BE _____	CA _____	_____ CA	_____ ECA
BI _____ DO	O _____	_____ BIDE	CA _____

a q u b A C S z m X N O P C G V

FORME PALAVRAS.

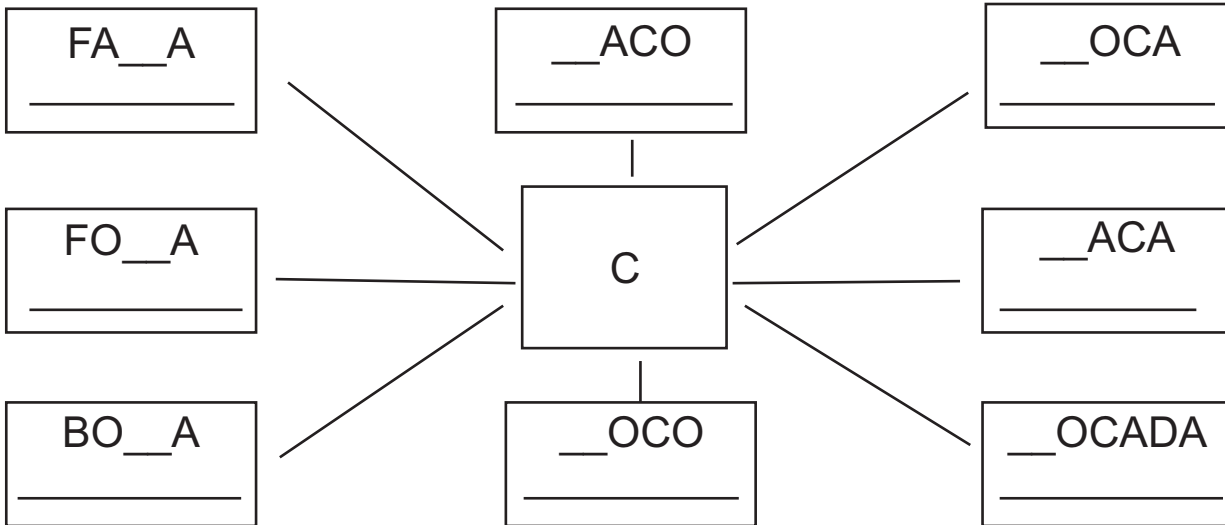

FAÇA UMA LISTA DE PALAVRAS QUE TENHAM AS SÍLABAS ABAIXO.











CA	CO	CU	CÃO
----	----	----	-----

ORDENE AS SÍLABAS E FORME AS PALAVRAS.

CA	E	CU	_____	CU	CA	Í	_____
A	BOU	CA	_____	CA	A	BEI	_____
CO	DA	CA	_____	BO	DA	CA	_____
O	CA	_____	CA	BI	_____		
CA	CU	_____	BO	CU	_____		
CAU	CA	_____	CA	BO	_____		

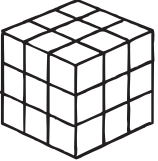
C b v H A B q A C u z m O X

EM CADA QUADRO CIRCULE A PALAVRA QUE CORRESPONDE AO DESENHO.

	CUÍCA CUECA COCO		COCA CABO COCADA		OCA COCA BOCA
	OCA CABO CÃO		CACO BOCA BICO		COCA COCO OCA
	BOCA BOBA CABO		CUBO CUÍCA COCA		CUCA CUCO CUBO
	CACO CUCA CACAU		CACO CAIO COCA		COCA COLA CUCA

OBSERVE OS DESENHOS E COMPLETE AS PALAVRAS COM AS SÍLABAS QUE FALTAM.



CO DA

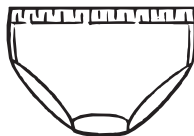

 E CA

CU Í



 TI A

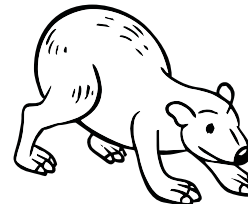

CO

 LA

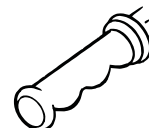

 BO

LEIA AS PALAVRAS DO QUADRO E
DEPOIS ESCREVA-AS NO LUGAR INDICADO.

CABO	CUCO	CUIA
CUBO	CACÁ	CÃO
CUTIA	CUÍCA	CAIO

NOME DE PESSOAS	NOME DE ANIMAIS	NOME DE OBJETOS

MARQUE AS SÍLABAS COM OS
SÍMBOLOS QUE APARECEM NO MODELO.

CA	-	CO	-	CU
x		■		*

A	CA	BA
---	----	----

CU	E	CA
----	---	----

CO	CA	DA
----	----	----

CO	CA
----	----

CU	Í	CA
----	---	----

BI	CA	DA
----	----	----

LIGUE AS PALAVRAS QUE
COMEÇAM COM A MESMA SÍLABA.

CACO	CUECA
COPO	CABO
CUCA	COCADA

BOCA	BEBIDA
BICOU	BÓIA
BECO	BICADA

COPIE AS FRASES SUBSTITUINDO OS DESENHOS PELAS PALAVRAS CORRESPONDENTES.

CAIO BEBEU



NO COPO.

A BALA É DE



O



É DO



CÃO



BEBE ÁGUA NA



QUAL É A PALAVRA? PINTE AS SÍLABAS QUE FORMAM OS NOMES DOS DESENHOS.

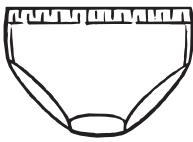

CU	CO
BO	E
CA	BA



BU	CO
BO	CU
BA	CA

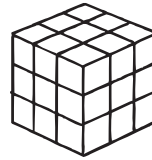

BA	CA
CU	BE
CO	BO

O	CO
BO	CA
BA	CU



BI	CA
CA	CU
BA	CO



CA	CU
BA	BO
CO	BU



CU	CO
CA	BE
BI	BU



CU	Í
BE	CO
CA	BO



CA	CO
BO	BA
CU	BI

COMPLETE AS FRASES COM
UMA DAS PALAVRAS DO QUADRO.

CUBO - COCO - COCADA

CAIO COMEU A _____.

CAIO - CABO - CUÍÁ

BIA VIU O _____.

CUCO - CAMA - COLA

O _____ BICOU O COCO.

CABO - COCA - BOCA

A _____ ESTÁ NO COPO.

CUÍCA - CUECA - CUCA

A _____ DE CAIO CAIU.

FORME PALAVRAS COM AS
SÍLABAS QUE ESTÃO NO DESENHO.

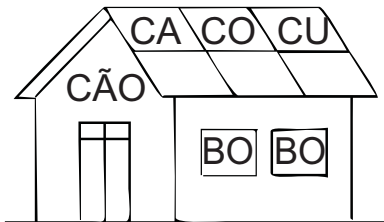

JUNTE AS SÍLABAS E FORME PALAVRAS.

CU CO _____	CA CO _____	O CA _____
CU E CA _____	CO CA _____	O CO _____
CU BO _____	CU Í CA _____	CO CO _____

LEIA AS PALAVRAS DO QUADRO
E RESPONDA O QUE SE PEDE.

CUECA – CAIO – BIA
COCO – COCA

QUAL É O NOME DO MENINO? _____

QUAL É O NOME DA MENINA? _____

DE QUE É A BALA? _____

É UMA PEÇA DE ROUPA. _____

O QUE ESTÁ NO COPO? _____

JUNTE OS NUMERAIS E FORME
PALAVRAS. DESENHE-AS AO LADO.

CO 1	CU 2
BI 4	O 5
E 3	CO 1
BO 2	CO 6
CO 4	CA 3
CA 5	CA 2
CA 6	DA 6

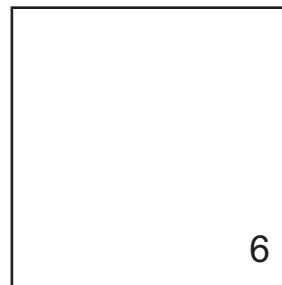
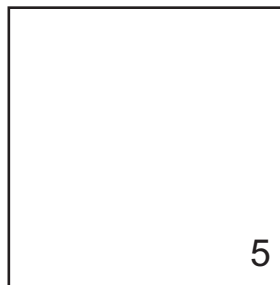
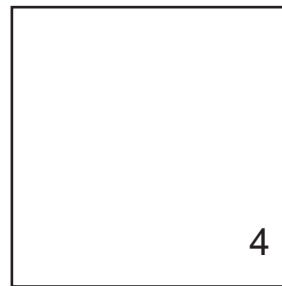
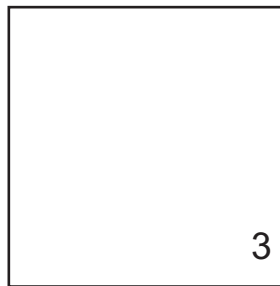
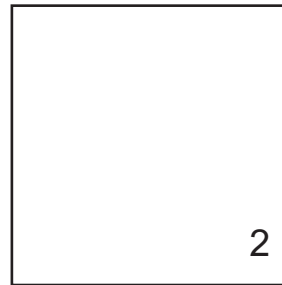

ORDENE AS PALAVRAS E FORME FRASES.

CUCO

O

COCO

BICOU

O

BALA

CACAU

A

É

DE

TOCA

CUÍCA

CAIO

A

PINTE NA MESMA COR CADA FIGURA IGUAL E ESCREVA AS PALAVRAS FORMADAS.

CU



CA



CO



BI









COMPLETE AS FICHAS FORMANDO PALAVRAS.

A		
	CA	
		BA

BI		
	BO	
		CA

		U
	CA	
CA		

	E	
CU		
		CA

		CA
	í	
CU		

BO		
	CA	
		DO

a q u b A C S Z m X N O P C G V

CAÇA-PALAVRAS

PARA CADA PALAVRA, USE UMA COR (CAÇA X BANCO PALAVRAS).

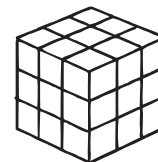
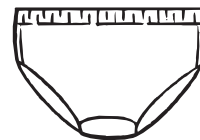
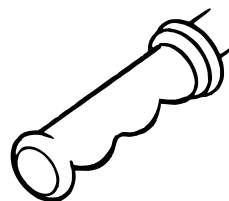
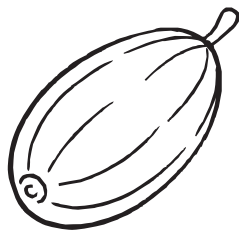

X	C	A	C	A	U	H	I
Z	U	E	F	G	B	J	C
C	Í	O	C	A	E	K	U
U	C	C	B	O	C	A	B
E	A	A	L	C	A	B	O
C	M	I	N	O	P	S	T
A	Q	O	R	C	O	C	A
U	B	I	C	O	V	A	X

BECA	CUÍCA	CUBO	BICO
COCO	CACAU	CABO	BOCA
CUECA	COCA	CAIO	OCA

C b v H a B q A C u z m O X

a q u b A C S Z m X N O P C G V

AUTODITADO

ESCREVA PALAVRAS QUE TENHAM
SÍLABAS DA FAMÍLIA DA LETRA **C**.

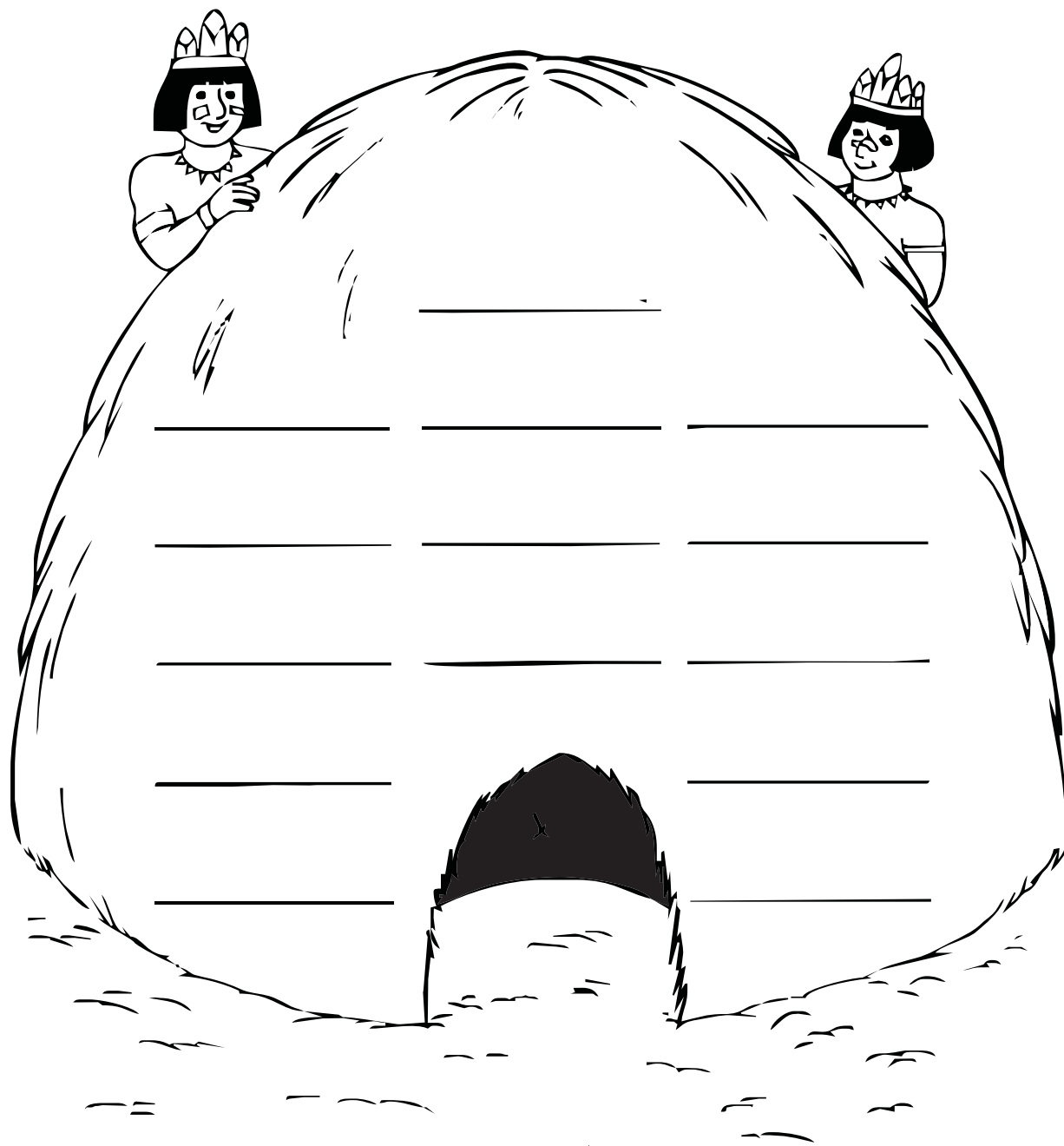

C b v h a B q A C u z m O X

a q u b A C S Z m X N O P C G V

DITADO

ESCREVA COM ATENÇÃO AS PALAVRAS QUE VOU DITAR.

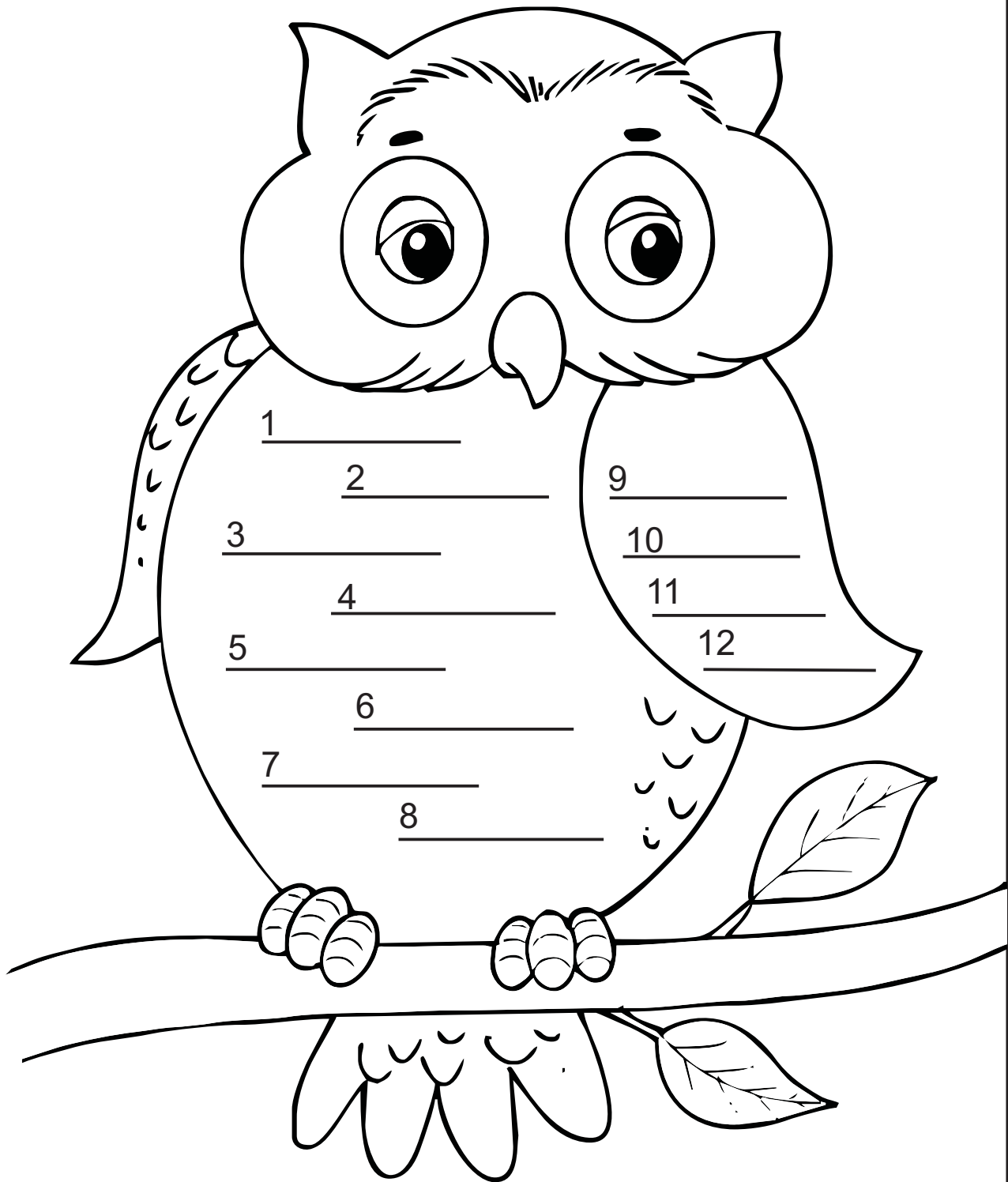

C b v H A B q A C u z m O X

PARLENDA

O DOCE PERGUNTOU PRO DOCE

QUAL É O DOCE MAIS DOCE.

O DOCE RESPONDEU PRO DOCE,

QUE O DOCE MAIS DOCE

É O DOCE DE BATATA-DOCE.

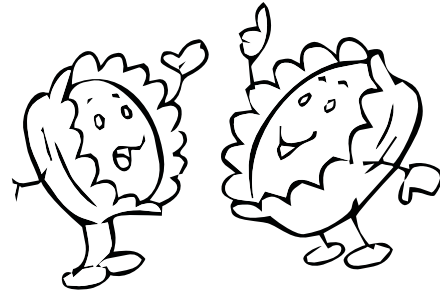

Domínio Público

CIRCULE NO TEXTO A PALAVRA DOCE.

COPIE A PALAVRA.

DOCE

doce

doce

COPIE A LETRA D-d.

D

D

d

d

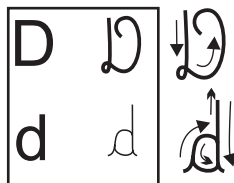
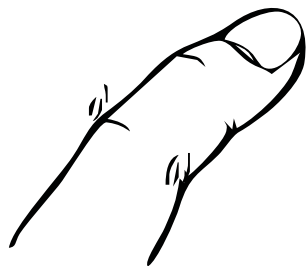

JUNTE A LETRA **D-d** COM AS VOGAIS
E FORME A FAMÍLIA SILÁBICA.

+	A	E	I	O	U
D					

COPIE.

DA - DE - DI - DO - DU

Da - De - Di - Do - Du

+	a	e	i	o	u	dão
d						

da - de - di - do - du - dão

da - de - di - do - du - dão

d

D

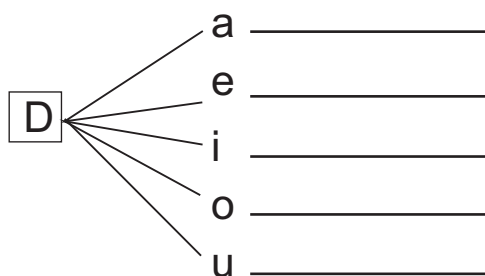
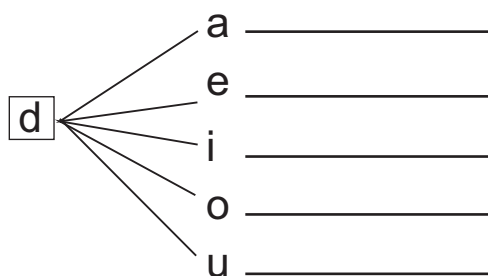

PINTE A LETRA **D-d** NAS PALAVRAS DO DADO.

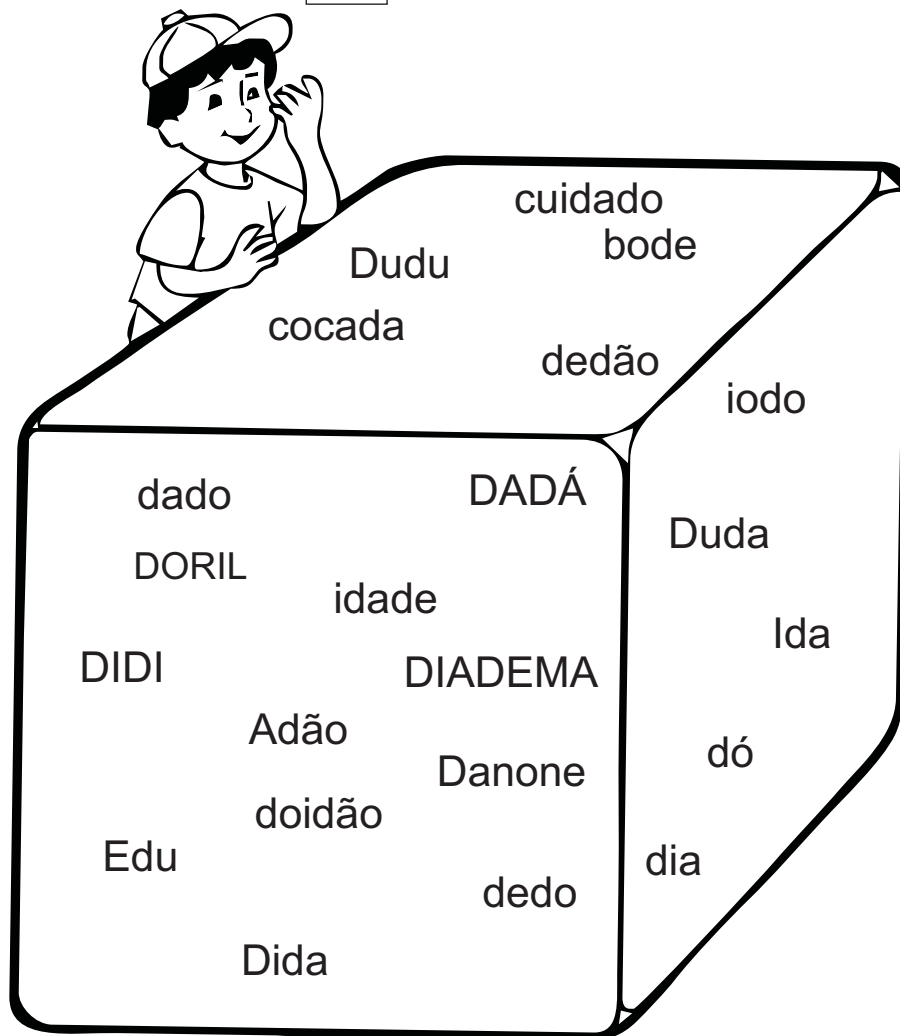

JUNTE AS SÍLABAS E FORME AS PALAVRAS.

DA DO _____ I DA DE _____

DE DO _____ CA DU CO _____

DI A _____ BI CA DA _____

DE DÃO _____ CA DE A DO _____

BO DE _____ CA BI DE _____

JUNTE AS SÍLABAS DE ACORDO COM OS NÚMEROS CORRESPONDENTES E FORME PALAVRAS.

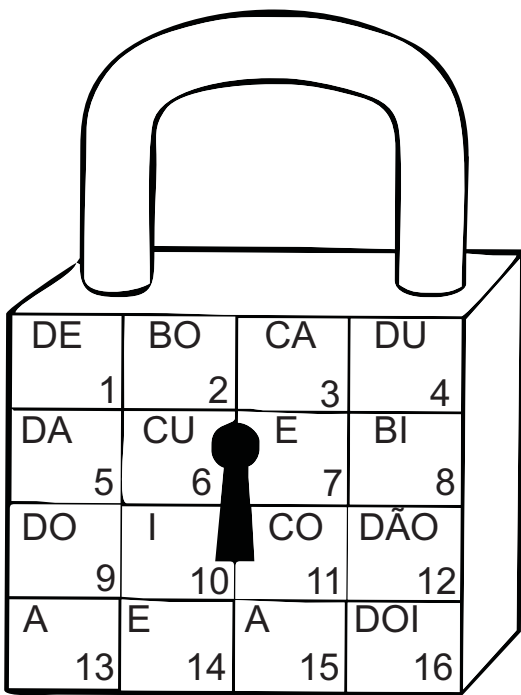

- 1-12 _____ 2-1 _____
- 3-8-1 _____ 1-9 _____
- 8-6-9 _____ 11-3-5 _____
- 7-4-3 _____ 13-12 _____
- 3-4-11 _____ 14-4 _____
- 10-5-1 _____ 15-4-2 _____
- 2-3-9 _____ 16-12 _____

FORME PALAVRAS UNINDO AS SÍLABAS.

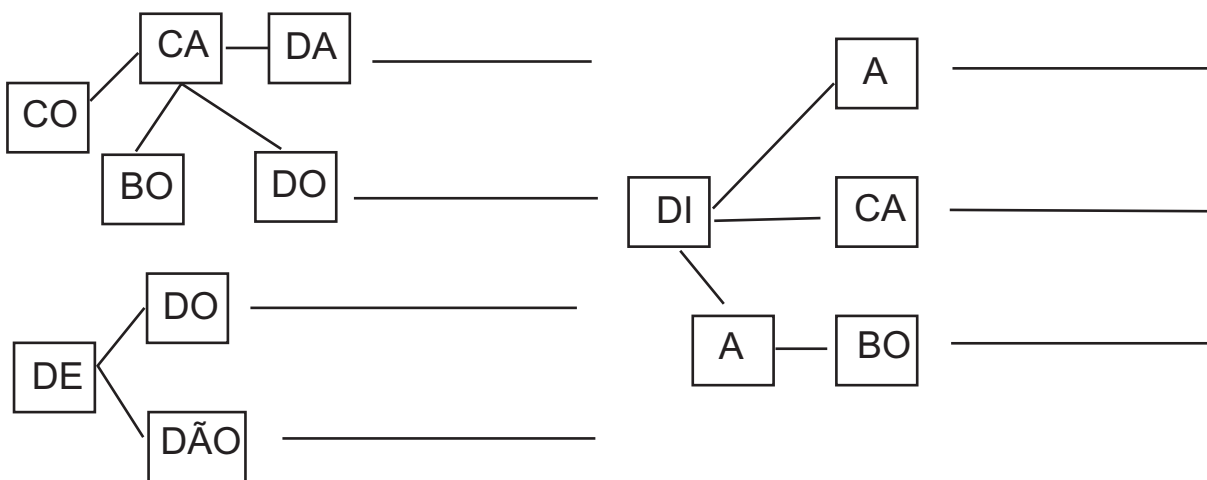

LIGUE AS PALAVRAS IGUAIS.

EDU	<i>Cda</i>	idade	<i>adubo</i>
IDA	<i>Edu</i>	adubo	<i>educa</i>
ADA	<i>Ida</i>	educa	<i>idade</i>

LIGUE OS DESENHOS AOS NOMES CORRESPONDENTES.



dado



bode



cabide



cadeado

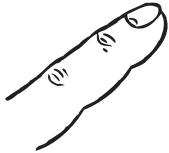

cocada

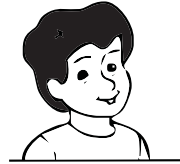

dado

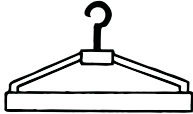

doce



Edu

OBSERVE OS DESENHOS E COMPLETE COM **B** OU **D**.

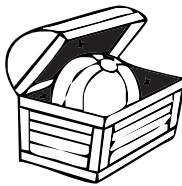

___ AÚ

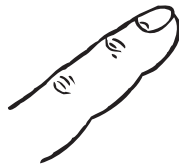

___ E ___ O

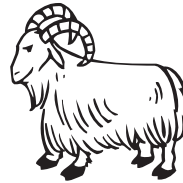

___ O ___ E



___ OCE

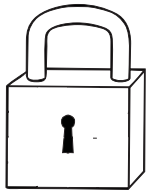

CA ___ EA ___ O



___ ICO



___ A ___ O

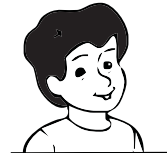

E ___ U

COPIE.

ba – be – bi – bo – bu

da – de – di – do – du

ORDENE AS SÍLABAS E FORME PALAVRAS.

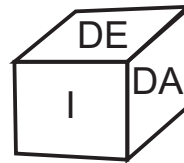
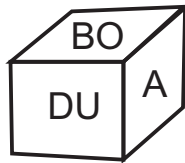
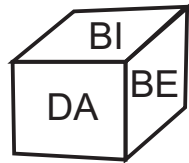
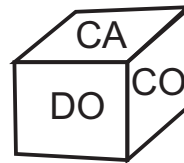
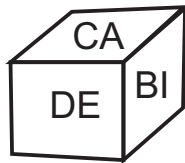
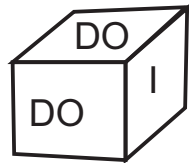

LEIA AS PALAVRAS DO QUADRO E DEPOIS
ESCREVA-AS ONDE É INDICADO.

ADÃO	CABIDE	BODE	IDA
COCO	EDU	CADEADO	CACAU
CUÍCA	BOI	DUDA	BÓIA

NOME DE PESSOAS

NOME DE OBJETOS

NOME DE ANIMAIS

NOME DE FRUTAS

COMPLETE AS PALAVRAS COM SÍLABAS
DA FAMÍLIA DA LETRA **D-d**.

___DO

BO___

E___

DE___

E___CA

A___

___ABO

BICA___

DU___

CA___CO

CUIDA___

DO___

BOIA___

DOÍ___

I___

LEIA AS PALAVRAS DO QUADRO E
COPIE ABAIXO SEPARANDO-AS DE
ACORDO COM A SÍLABA EM DESTAQUE.

EDUCA	DEDÃO	DOIDA	CADUCO
DEDO	ADUBO	DOEU	DIA
DIABO	ADIA	DADO	EDE
IDA	BEBIDA	DUDA	ADÃO
DIDA	BODE	CABIDE	DICA

DA

DE

DI

DO

DU

DÃO

LIGUE AS PALAVRAS QUE COMEÇAM
COM A MESMA SÍLABA.

DADO

DIA

BOCA

BICADA

DOIDO

DUDA

BECO

BANANA

DICA

DEU

BICO

BUZINA

DUDU

DOEU

BALA

BOLA

DEDO

DAMA

BULE





BECA

PINTE AS FICHAS DAS PALAVRAS DE ACORDO COM A SÍLABA INICIAL. USE AMARELO PARA A LETRA **B** E VERMELHO PARA A LETRA **D**.

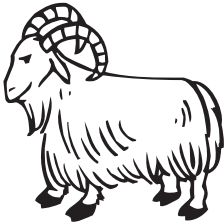
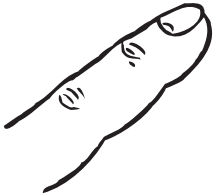
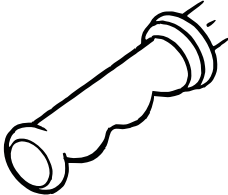
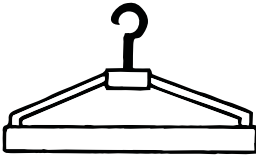
BODE	DEDO	DADO	BANANA
DOCE	BOBA	BALA	DAMA
DOEU	DEDÃO	BOBÃO	BECA
BECO	DIA	DIABO	BOCA
BICA	BULE	BICADA	BUZINA

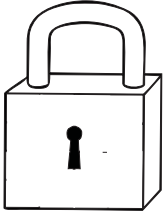
PINTE AS FICHAS DAS PALAVRAS QUE INDICAM OS NOMES DOS DESENHOS.

			
BOCA	DEDO	CABO	DICA
DOCE	EDUCA	CADEADO	CABIDE
BODE	DADÃO	DAMA	DIABO

			
EDU	COCADA	EDU	DIA
CADEADO	COCA-COLA	DOCE	IDA
DOIDO	CUIDADO	DADO	DADO

ORDENE AS PALAVRAS E FORME FRASES.

COCADA.
4

IDA
1

A
3

COMEU
2

NO
4

BEBIDA
2

A
1

COPO.
5

ESTÁ
3

EDU
3

BIA
1

COCADA.
6

COMERAM
4

E
2

TODA
5

CUCO
2

O
4

EDU.
7

O
1

BICOU
3

DEDO
5

DO
6

JUNTE AS SÍLABAS DE ACORDO
COM AS FIGURAS E FORME PALAVRAS.

CO

E

DA

CA

DU

DO



a q u b A C S Z m X N O P C G V

CAÇA-PALAVRAS

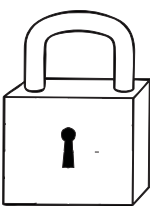
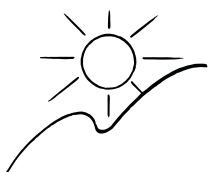

W	C	O	C	A	D	A	B
D	I	A	J	B	O	D	E
A	D	I	K	N	C	P	I
D	F	M	Q	X	A	H	D
O	G	D	I	A	B	O	A
H	L	E	R	V	I	Y	D
C	A	D	E	A	D	O	E
S	T	O	Z	W	E	X	Z

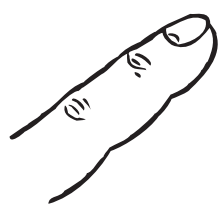
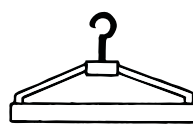

7 ANOS



DIA	IDADE	BODE
DEDO	COCADA	DADO
CADEADO	DIABO	CABIDE

C b v H a B q A C u z m O X

a q u b A C S z m X N O p c G V

AUTODITADO

ESCREVA PALAVRAS QUE TENHAM
SÍLABAS DA FAMÍLIA DA LETRA **D**.

The image shows a 3D cube-shaped writing template. The top face has three horizontal lines and a central oval marker with a plus sign. The front face has four horizontal lines and two circular markers with plus signs. The right face has three horizontal lines and three oval markers with plus signs.

C b v H a B q A C u z m O X

DITADO
CAPRICHE NA ESCRITA.

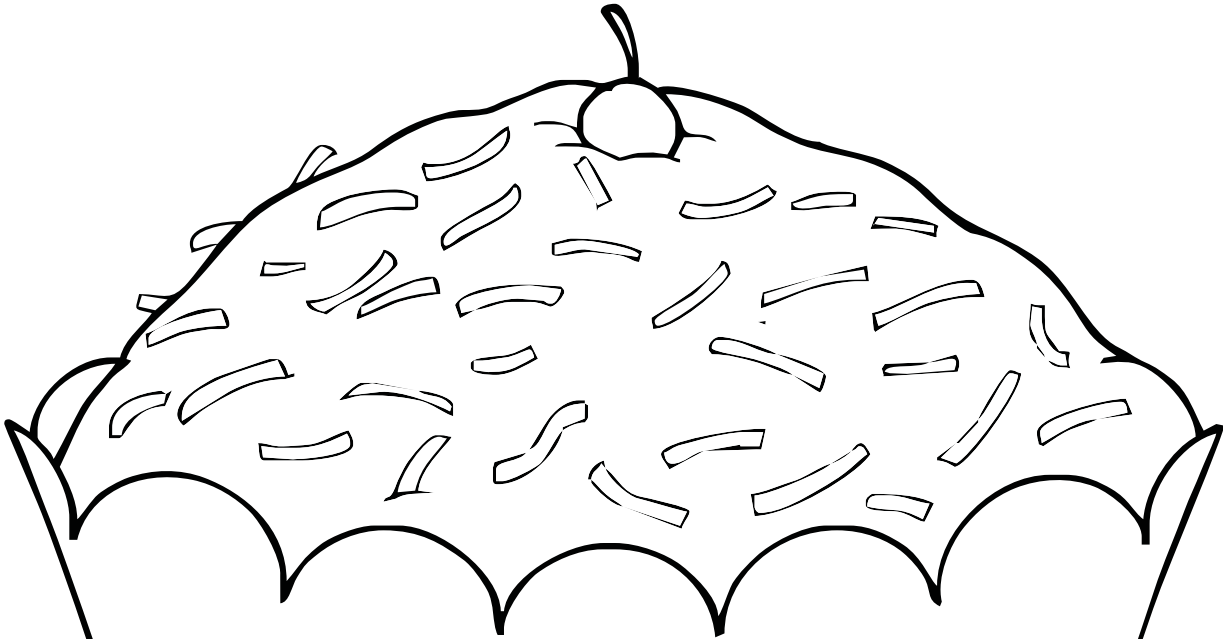

1 _____	6 _____
2 _____	7 _____
3 _____	8 _____
4 _____	9 _____
5 _____	10 _____

FACA E FACÃO

COM UMA FACA
MAMÃE CORTOU O PÃO.
FÁBIO PEGOU A FACA
E DERRUBOU NO CHÃO.

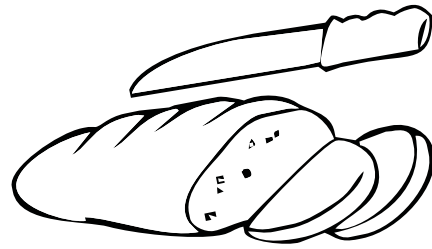

FACA E FACÃO
NÃO BRINQUE COM ISSO NÃO.
FA-FE-FI-FO-FU
VOCÊ PODE CORTAR A MÃO.

CIRCULE NO TEXTO AS PALAVRAS QUE TÊM A LETRA F-f.
DEPOIS, COPIE AS PALAVRAS.

COPIE AS LETRAS.

faca-	Fábio-
faca-	Fábio-

COPIE AS LETRAS.

f	
F	

COPIE A FAMÍLIA SILÁBICA.

fa - fe - fi - fo - fu - fã
Fa - Fe - Fi - Fo - Fu

PINTE A LETRA **F-f** NAS PALAVRAS ESCRITAS NO DESENHO.

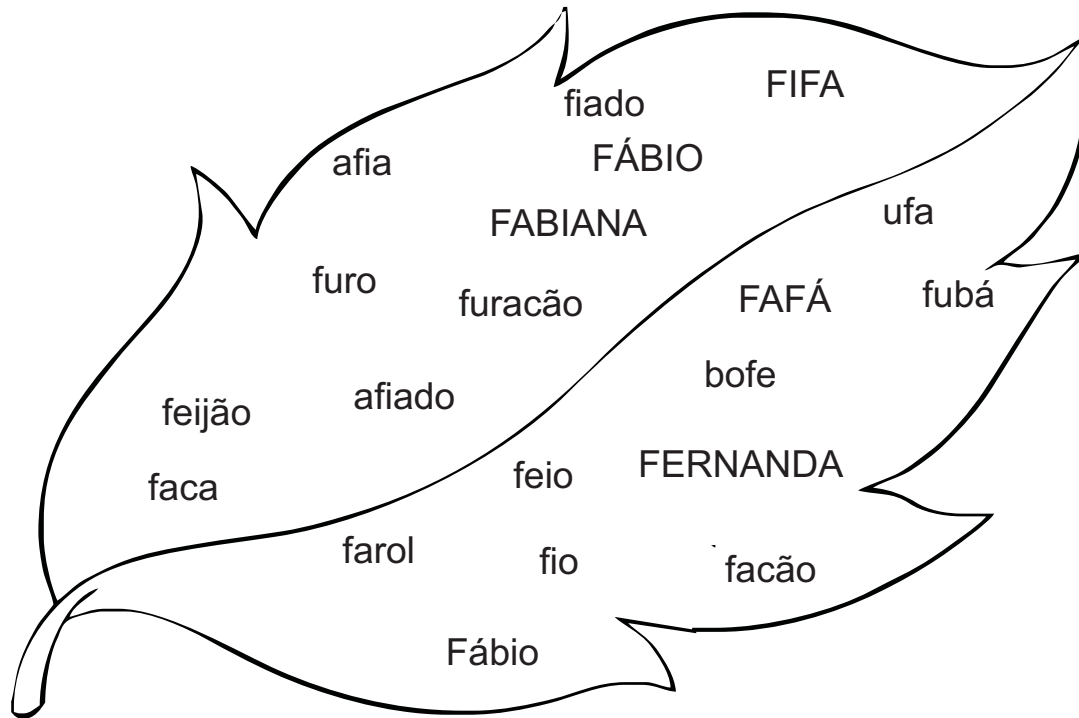

JUNTE A LETRA **F-f** COM AS VOGAIS E FORME A FAMÍLIA SILÁBICA.







f a _____
e _____
i _____
o _____
u _____

F a _____
e _____
i _____
o _____
u _____









fa - fe - fi - fo - fu - fã

fa - fe - fi - fo - fu - fã

CIRCULE AS PALAVRAS QUE INDICAM OS NOMES DOS DESENHOS.

	BOFE FEIJÃO FADA		FIO FUBÁ FACÃO		FOCA FEIJÃO CAFÉ
	CAFÉ UFA FAMA		FOI BAFO FADA		FADA FOGO FITA

LIGUE OS DESENHOS AO SEU NOME.

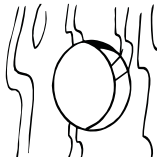
	FACA	FITA	
	FEIJÃO	FURO	
	FOCA	FOGO	
	FERRO	CAFÉ	
	FUBÁ	FADA	

LIGUE AS PALAVRAS IGUAIS.

fita	Fábio	FABIANA	foca
fogo	feijão	FIO	Fabiana
Fábio	fubá	FOCA	fio
fubá	fogo	FERRO	furo
feijão	fita	FURO	ferro

ESCREVA PALAVRAS ORDENANDO AS SÍLABAS.

A	BA	FO	DA
1	3	2	4

CÃO	FA
2	1

DA	CA	FA
3	2	1

DO	FI	A	A
4	2	1	3

FO	FO	CA
2	1	3

DA	FA	BA	A
4	3	2	1

FÃO	BI
2	1

GA	A	FO
3	1	2

ESCREVA AS SÍLABAS DAS PALAVRAS
NO QUADRO ABAIXO FORMANDO PALAVRAS.



	A			
	FI			
	A			
	DA			

- CAFÉ
- ABAFADA
- AFOGA
- FADA
- ABAFÁ
- FACADA
- AFIADA**
- FACA

COPIE.

Fa - Fe - Fi - Fo - Fu -

Ja - Je - Ji - Jo - Ju -

ESCOLHA UMA DAS PALAVRAS, FAÇA O DESENHO E ESCREVA-AS ABAIXO DE CADA QUADRO.

BIFE CAFÉ HOJE	
----------------------	--

FADA FACA FÁBIO	
-----------------------	--





FOGO FOGÃO FOFOCA	
-------------------------	--

FURO FUBÁ FUI	
---------------------	--

FIO FIVELA FILÉ	
-----------------------	--

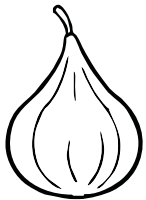
FABIANA FEIJÃO FOCA	
---------------------------	--

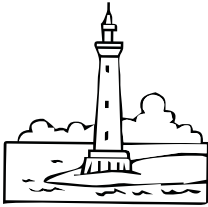
COMPLETE AS SÍLABAS QUE FALTAM NAS PALAVRAS.

			
__GO	CA__	__ROL	__CA

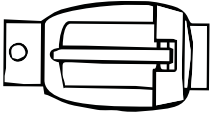
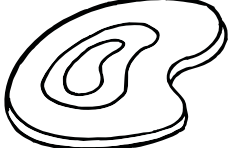
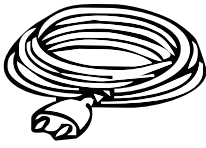
			
__GO	__VELA	BI__	__O

ESCREVA AS PALAVRAS JUNTANDO AS SÍLABAS.

A 1	FU 2	FA 3	CA 4
CÃO 5	FI 6	FÉ 7	DO 8
FO 9	BÁ 10	BO 11	DA 12

1+6+1 _____

3+4 _____

2+10 _____

3+5 _____

3+4+12 _____

4+7 _____

10+9 _____

11+7 _____

6+4 _____

9+3 _____

9+9+4 _____

6+1+8 _____

ESCREVA OS NOMES DOS DESENHOS.

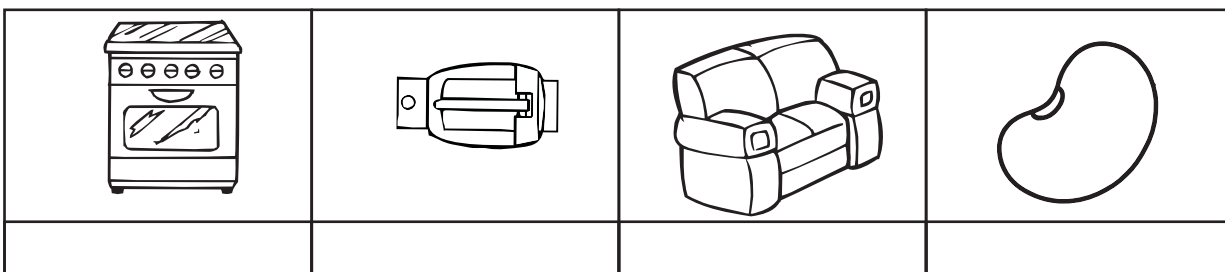
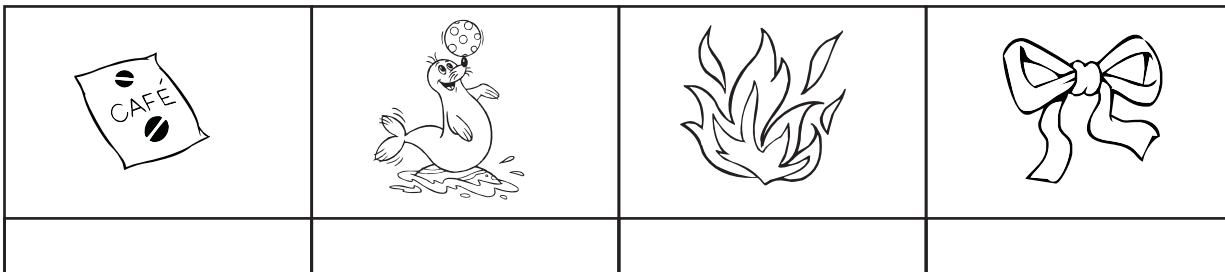
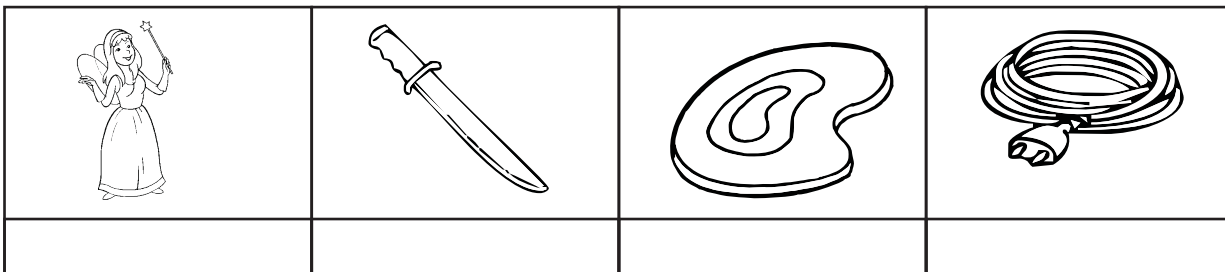

RECORTE AS SÍLABAS DO QUADRO E COLE-AS
 ABAIXO DOS DESENHOS FORMANDO AS
 PALAVRAS CORRESPONDENTES.

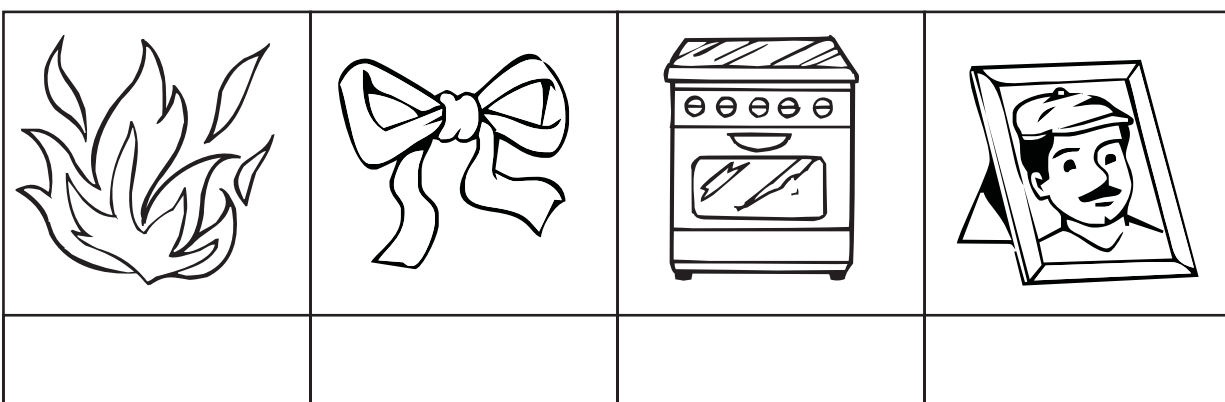
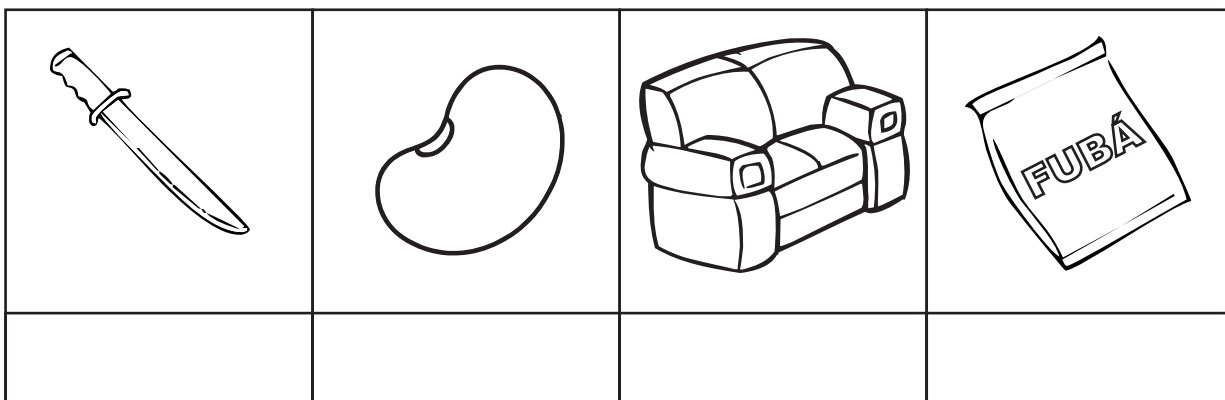
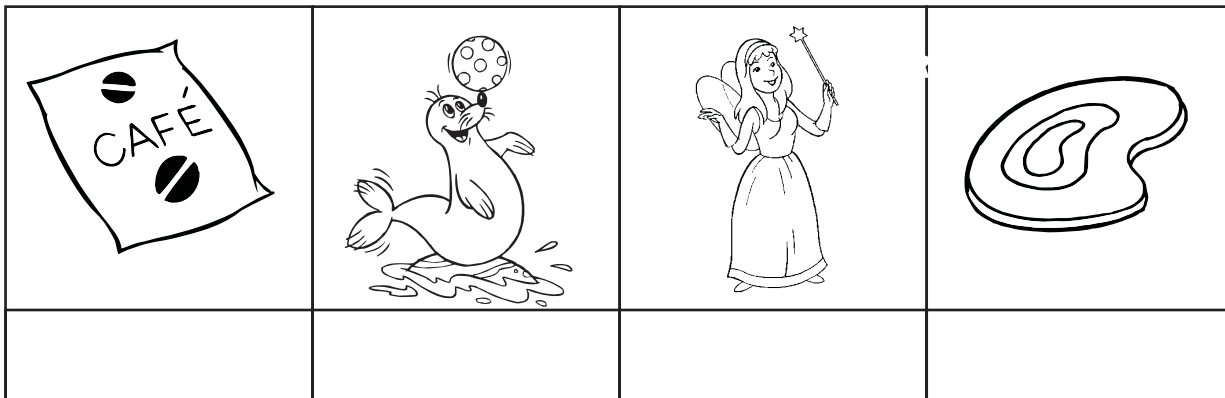

CA	DA	FO	FE	FEI	BÁ	GO	TA
FA	FÉ	BI	FA	JÃO	FO	FO	FO
FÁ	SO	CA	CA	FU	GÃO	FI	TO

COMPLETE AS FRASES COM
UMA PALAVRA DO QUADRO.

FADA - FUBÁ - UFA

BIA FEZ UMA FAROFA DE _____.

CAFÉ - FOCA - ABAFOU - FITA

MAMÃE _____ O CAFÉ NO BULE.

FEIO - BOFE - FOFO - FADA

O CÃO COMEU TODO O _____.

FAFÁ - FOFA - AFIADO - FOGO

O FACÃO ESTÁ MUITO _____.

CAFÉ - FÁBIO - FOCA - FUBÁ

_____ AFIOU A FACA.

COPIE DOS VERSINHOS AS
PALAVRAS QUE TÊM A LETRA **F**.

O "F" É DE FAROFA,
FITA, FACA E FUBÁ.
FÁBIO FAZ FOLIA
COM A FOCA NO SOFÁ

F	

SEPARE AS PALAVRAS EM LETRAS E SÍLABAS.

FAROFA				

FUBÁ			

SOFÁ			

FOLIA				

ASSINALE AS FRASES QUE
CORRESPONDEM AOS DESENHOS.



A FITA CAIU DO CABELO.
A FITA ESTÁ NA GAVETA.
A FITA ESTÁ NO CABELO.

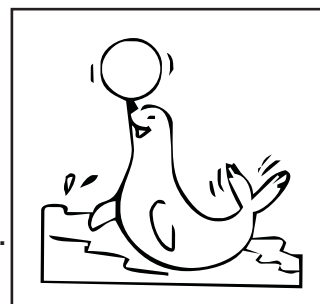

A FOCA JOGA BOLA.
A BOLA É DE BIA.
A BOLA DE FÁBIO FUROU.

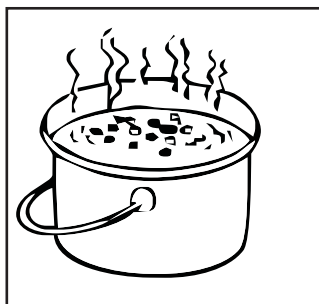

O FEIJÃO ESTÁ NO JACÁ.
O FEIJÃO ESTÁ NA PANELA.
O FEIJÃO CAIU NO CHÃO.

ORDENE E COPIE AS FRASES.

















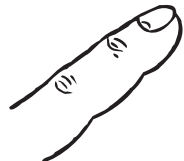
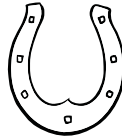





FIVELA. FABIANA UMA TEM

A COMEU FÁBIO FEIJOADA DA PANELA.

O MAMÃE BIFE. FRITOU A

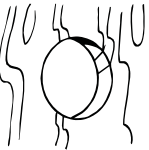
FOFINHO. FEZ VOVÓ UM BOLO A

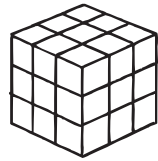
PINTE OS DESENHOS CUJAS PALAVRAS
TÊM A SÍLABA EM DESTAQUE.

FA					
FE					
FI					
FO					
FU					

LEIA AS PALAVRAS E DEPOIS COPIE-AS
SEPARANDO DE ACORDO COM AS SÍLABAS.

FUBÁ	AFIA	FOGO	CAFÉ	FUI
FACADA	FUÁ	FÁBIO	FIADO	FEIA
FOFO	BOFE	FOCA	FAFÁ	FIO
BIFE	FURO	FIGA	AFOGA	UFA

FA	FE	FI	FO	FU
_____	_____	_____	_____	_____
_____	_____	_____	_____	_____
_____	_____	_____	_____	_____
_____	_____	_____	_____	_____

CAÇA-PALAVRAS

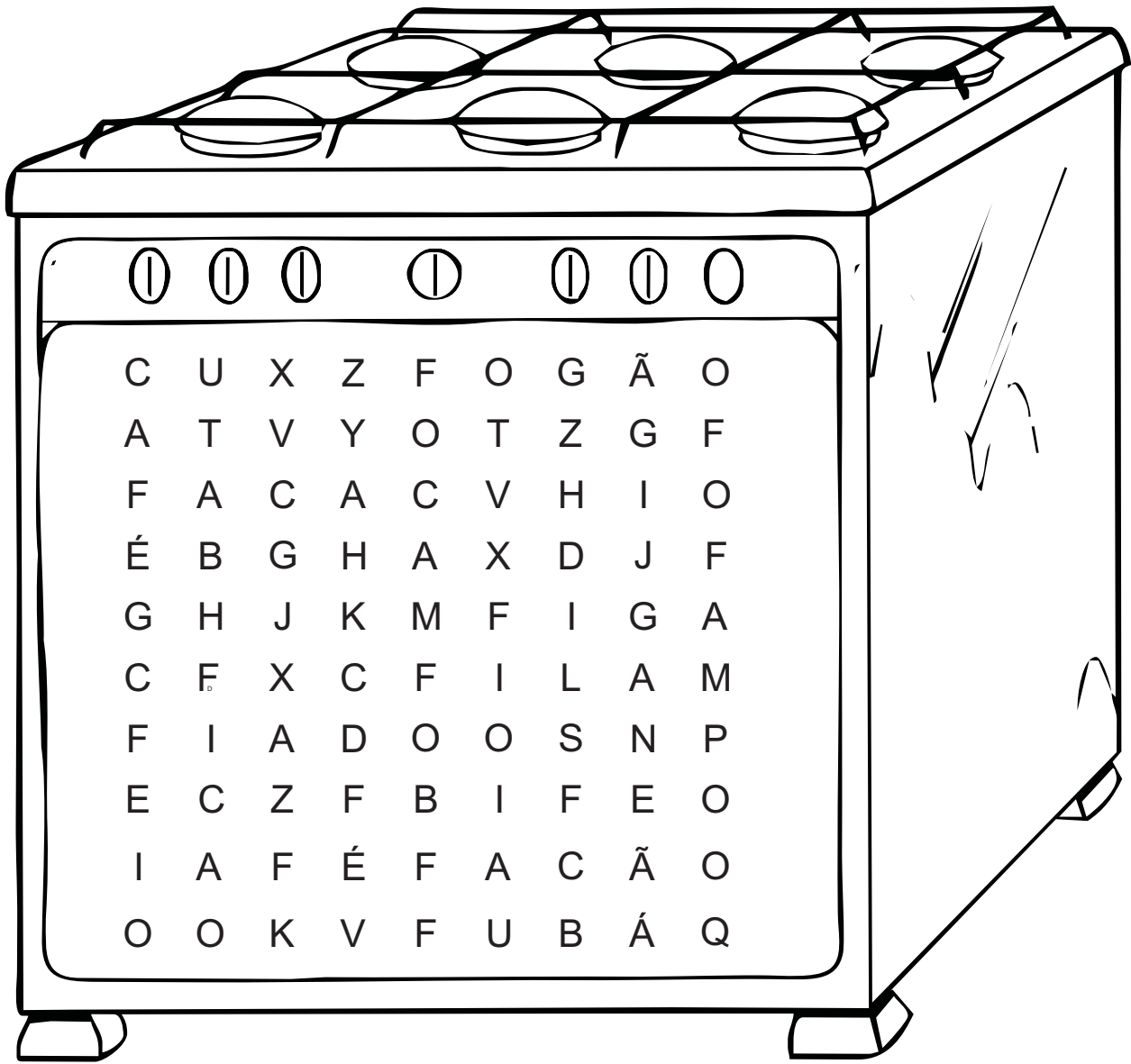

FOGÃO	FACÃO	FICA	CAFÉ	FIGA
FOCA	FACA	FEIO	FUBÁ	FIO
FIADO	FOFA	BIFE	FÉ	FILA

a q u b A c s z m x N O p c g v

p

c

z

v

o

g

s

a

s

u

d

q

n

g

s

h

h

c

b

AUTODITADO

ESCREVA PALAVRAS COM SÍLABAS DA FAMÍLIA DA LETRA F.

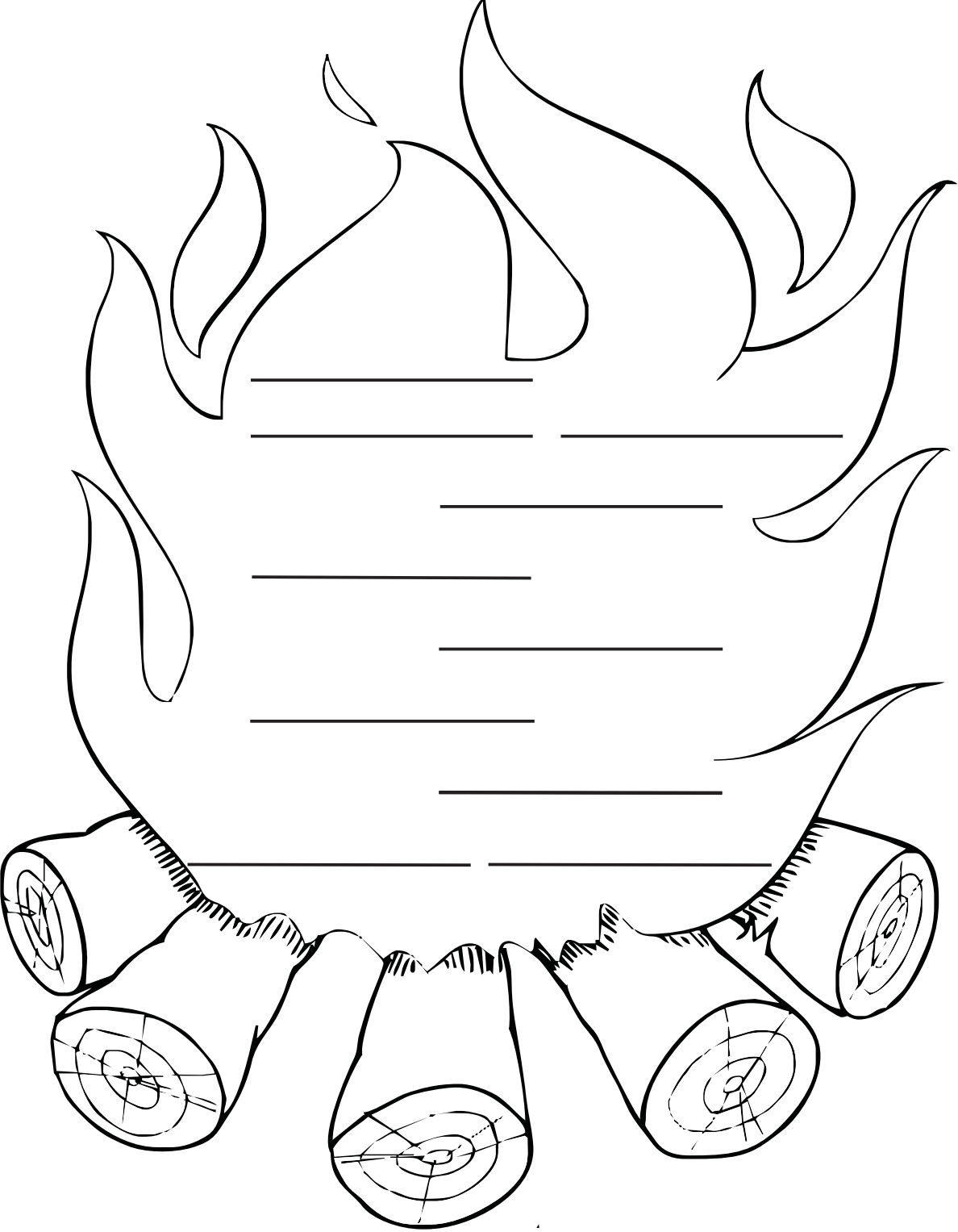

c b v h a B q A C u z m o x

DITADO
CAPRICHE NA ESCRITA.

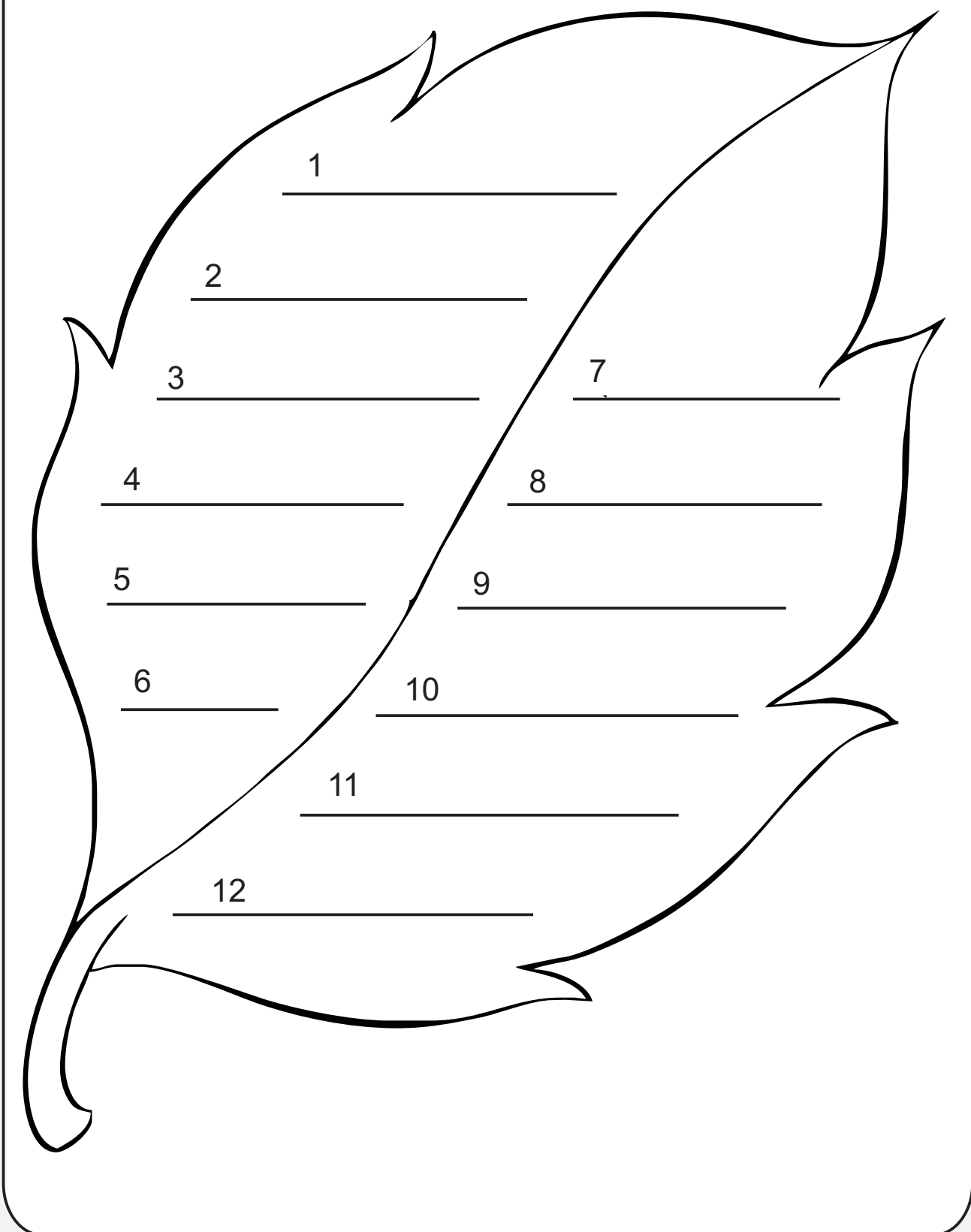

O GALO E A GALINHA

O GALO E A GALINHA
FORAM À FESTA EM PORTUGAL.
O GALO FOI DE SAIA
E A GALINHA DE AVENTAL. } BIS
ERA DE FRENTE PRA FRENTE.
ERA DE TRÁS PRA TRÁS.



Cantigas Infantis, Ciranda Cultural, pág. 59

CIRCULE NO TEXTO AS PALAVRAS QUE
TÊM A LETRA **G-g**.

COPIE AS PALAVRAS QUE VOCÊ CIRCULOU.

COPIE A PALAVRA.

GALO -

galo -

galo

COPIE A LETRA **G-g**.

g

g

G

G

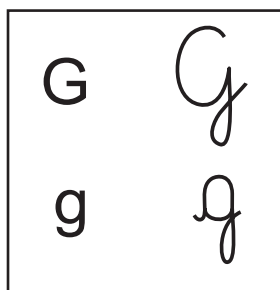

JUNTE A LETRA **G-g** COM AS VOGAIS
E FORME A FAMÍLIA SILÁBICA.

+	A	O	U
G			

COPIE.

GA - GO - GU

Ga Go Gu

+	a	o	u	ão
g				

ga - go - gu - gão

ga - go - gu - gão

ga - go - gu - gão

Ga - Go - Gu

a q u b A C S Z m X N O P C G V

LEIA AS PALAVRAS E DEPOIS ESCREVA-AS,
SEPARANDO NA COLUNA ADEQUADA DE
ACORDO COM A SÍLABA INDICADA.

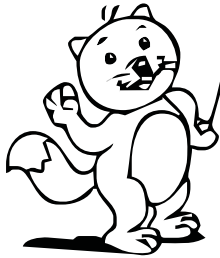

figo

gato

Gugu

fogão

goiaba

bigodão

água

gude

ADEGA

GUGA

dogão

fogão

gato

GOIABA



GA	GO	GU	GÃO
_____	_____	_____	_____
_____	_____	_____	_____
_____	_____	_____	_____
_____	_____	_____	_____

ORDENE AS SÍLABAS E ESCREVA AS PALAVRAS

A GA FO DO

DO FÍ GA

DO BI GO DU

DA GOI A BA

DE A GA

BI DÃO GO

GA RO BI BA

TA GAI

GO GA LE

C b v H a B q A C u z m O X

a q u b A C S Z m X N O P C G V

LIGUE CADA DESENHO AO SEU NOME.

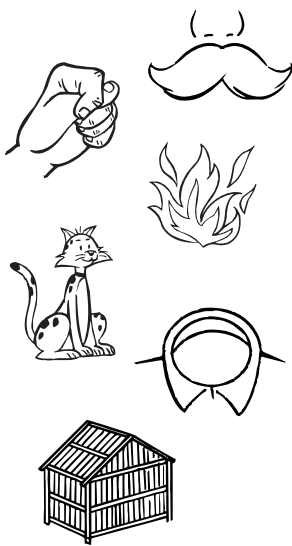

FOGO	ÁGUA
BIGODE	GOIABA
FIGA	FOGÃO
GAIOLA	ÉGUA
GATO	FIGO
GOLA	GALO

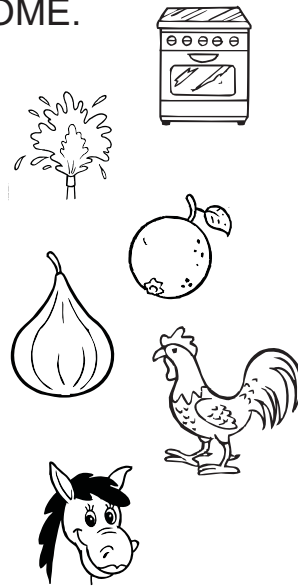

LEIA AS SÍLABAS NOS GATINHOS E PINTE-AS NAS PALAVRAS ABAIXO. PARA CADA SÍLABA USE COR DIFERENTE.

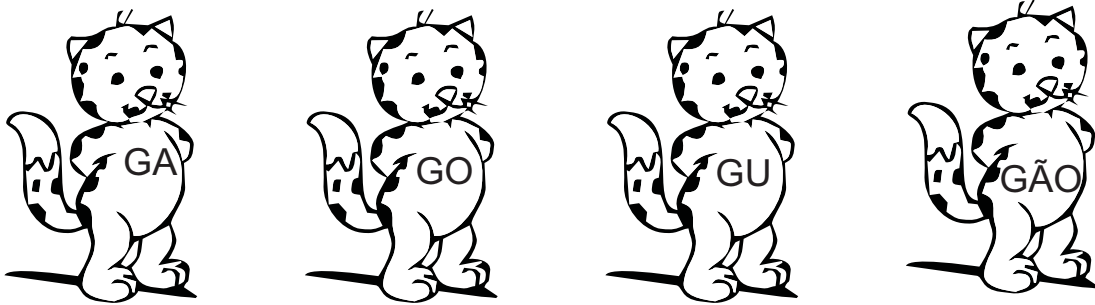

GAGO	FIGO	DOGÃO	FUGA
FOGO	GALO	BIGODE	GAIOLA
ADEGA	ÁGUA	ÉGUA	GOIABA
GUDE	FÍGADO	GADO	GABIROBA
GOLA	FOGÃO	FIGA	AGUDO

JUNTE E FORME PALAVRAS.

GA	GO	_____	GO	IABA	_____
	IOLA	_____		IABADA	_____
	TO	_____		MA	_____
	ITA	_____		TA	_____
	LO	_____		LA	_____

C b v H a B q A C u z m O X

NUMERE AS PALAVRAS DE ACORDO COM OS DESENHOS.

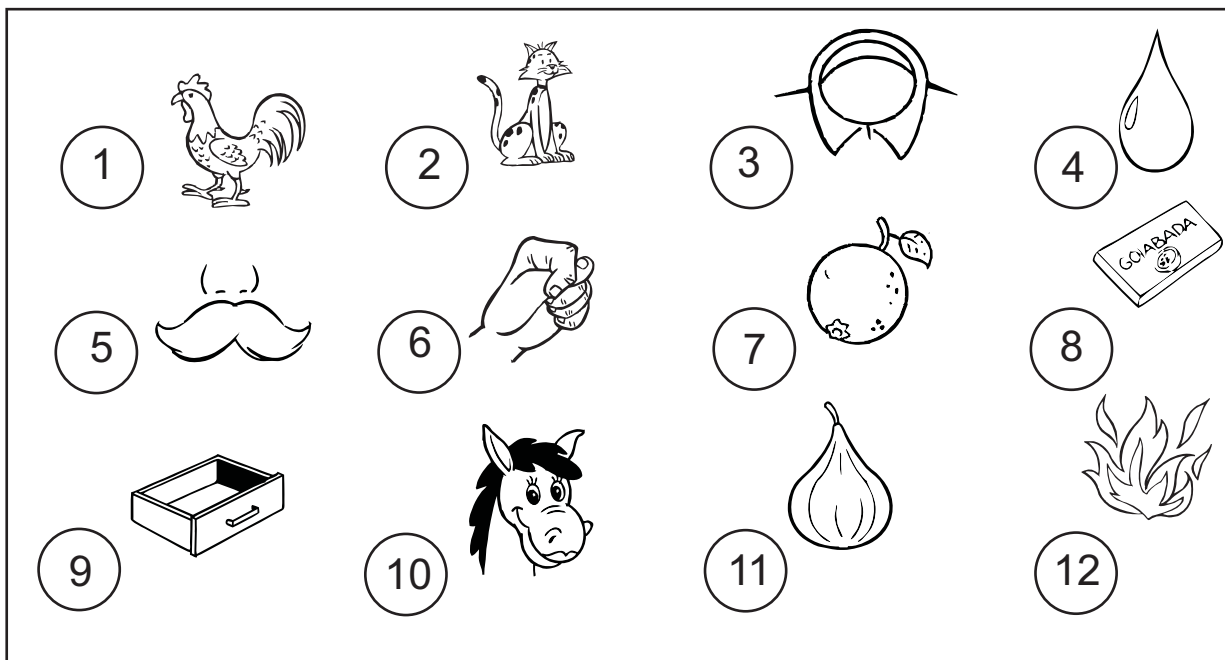

- | | | | | | |
|-----------------------|--------|-----------------------|--------|-----------------------|----------|
| <input type="radio"/> | GOIABA | <input type="radio"/> | ÉGUA | <input type="radio"/> | FOGO |
| <input type="radio"/> | GOTA | <input type="radio"/> | GOLA | <input type="radio"/> | GOIABADA |
| <input type="radio"/> | GALO | <input type="radio"/> | GAVETA | <input type="radio"/> | GATO |
| <input type="radio"/> | FIGO | <input type="radio"/> | FIGA | <input type="radio"/> | BIGODE |

FORME PALAVRAS.

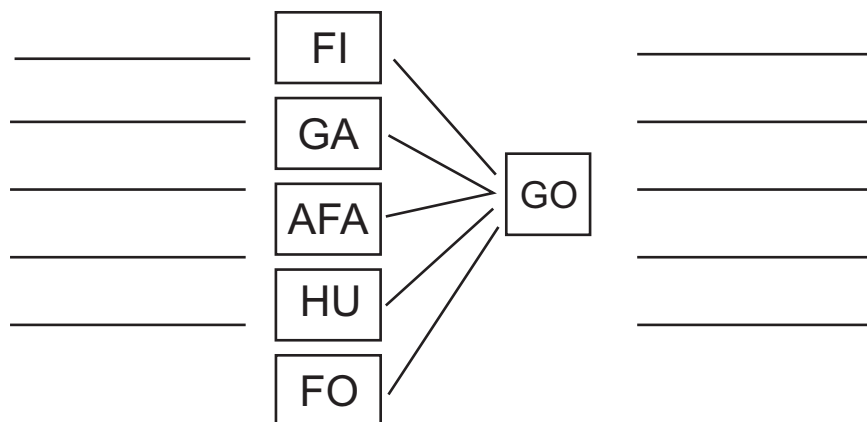
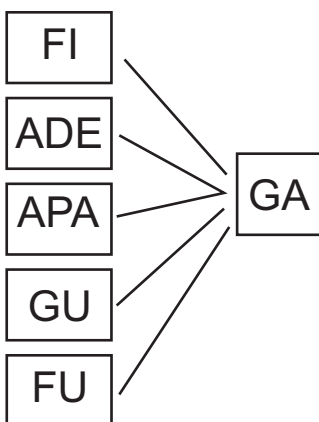

COMPLETE AS PALAVRAS COM UMA DAS SÍLABAS E COPIE-AS.

AFA _____ GO
FO _____ GA

____ GO GO
FI _____ GA













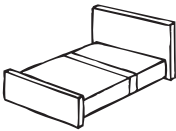

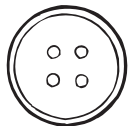

FÍ _____ DO GO
____ IABA GA

____ IABADA GA
____ IOLA GO

____ DE GA
____ TO GU

FO _____ GUA
É _____ GÃO

PINTE OS DESENHOS CUJOS
NOMES TÊM A SÍLABA INDICADA

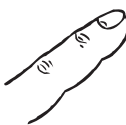
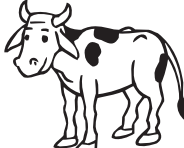
GA					
GO					
GU					
GÃO					

OBSERVE OS DESENHOS, ESCREVA OS NOMES E DEPOIS COPIE-OS, DE ACORDO COM O NÚMERO DE SÍLABAS.

			
			
2 SÍLABAS		3 SÍLABAS	
_____		_____	
_____		_____	

VEJA OS DESENHOS, LEIA AS PALAVRAS E ESCREVA OUTRAS QUE TENHAM A SÍLABA EM DESTAQUE.

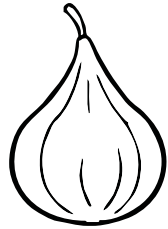
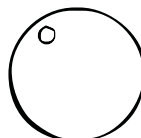
		
FI(GA)	FI(GO)	(GU)DE
_____	_____	_____
_____	_____	_____
_____	_____	_____

DESCUBRA O SEGREDO E COMPLETE.

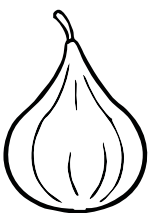
	FIGO			

	BIGODE			

	GOTA			

	GATO			

	FIGA			

	FOGO			

COMPLETE AS PALAVRAS ABAIXO COM AS SÍLABAS.

ga - go - gu - gão GA - GO - GU

___go	___ga	fo___
___iaba	fo___	___to
afo___	bi___de	fi___
a___do	Gu___	___iabada
___la	___iola	___la

ESCREVA OUTRAS PALAVRAS INICIADAS COM A SÍLABA EM DESTAQUE.

GA	TO	_____	A	GU	DO	_____
BI	GO	DE	_____	FO	GO	_____
A	DE	GA	_____	GO	LA	_____

DESCUBRA O SEGREDO E CONTINUE.



	DE
FO	
	DO
	LA

FÍ		DO
	VE	TA
BI		DE
A	DE	

BI		DU	DO
A	FO		DO
	BI	RO	BA
	IA	BA	DA

ENCONTRE AS SÍLABAS QUE FORMAM OS NOMES DAS FIGURAS E CIRCULE-AS.



GA	CA
BO	GO
TO	



CA	IO
GA	DO
LA	

GA	GU
GO	LA
LO	



GA	GU
GO	LA
LO	





BA	GO
BI	GA
DE	DA



GA	BI
FI	CA
GO	

COMPLETE AS FRASES COM PALAVRAS DAS FICHAS.

FIGO **GOIABA** **GAVETA**
 PAPAÍ COLOCOU A MEIA NA _____.

BIGODE **FOGÃO** **GAIOLA**
 MAMÃE PÕE A PANELA NO _____.

GAITA **ÉGUA** **GALO.**
 GUGA PEGOU A _____ DO GUGU.

ÁGUA **GOIABA** **ADEGA**
 A _____ ESTÁ MADURA.

BIGODÃO **GALO** **FOGÃO**
 MIMI TEM UM _____.

COMPLETE AS PALAVRAS COM SÍLABAS DA LETRA **G**.
 DEPOIS COPIE E SEPRE-AS EM SÍLABAS.

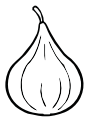

FI _____

--	--



____TO

--	--

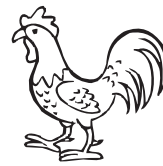

____LO

--	--



FO _____

--	--



BI _____DE

--	--	--

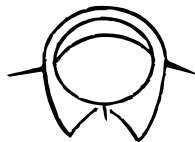

____LA

--	--



FI _____

--	--



FO _____

--	--

TROQUE OS NUMERAIS POR SÍLABAS
CORRESPONDENTES E FORME AS PALAVRAS.

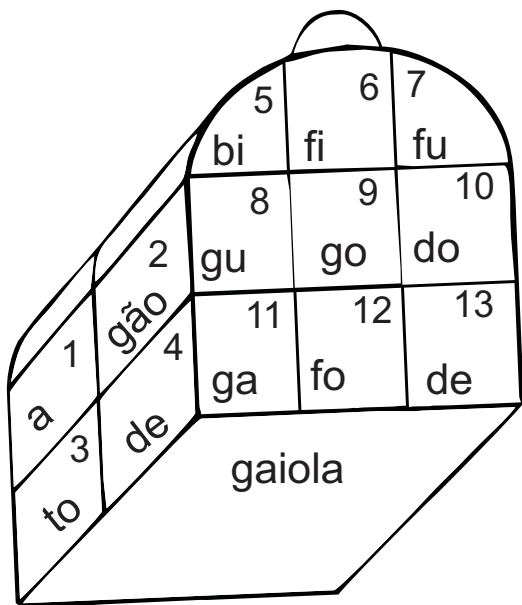

5-9-13 _____ 8-4 _____

11-10 _____ 7-11 _____

11-9 _____ 1-8-10 _____

6-9 _____ 12-2 _____

12-9 _____ 1-12-11 _____

1-4-11 _____ 11-3 _____

COPIE AS FRASES SUBSTITUINDO
OS DESENHOS POR PALAVRAS.

O  DO  DE GUGU É GRANDE.

MAMÃE FEZ DOCE DE .

O  É DE FÍGADO DE BOI.

GUGU FEZ  E GANHOU O JOGO.

CAÇA-PALAVRAS

ENCONTRE AS PALAVRAS, PROCURE-AS
NA VERTICAL E NA DIAGONAL.

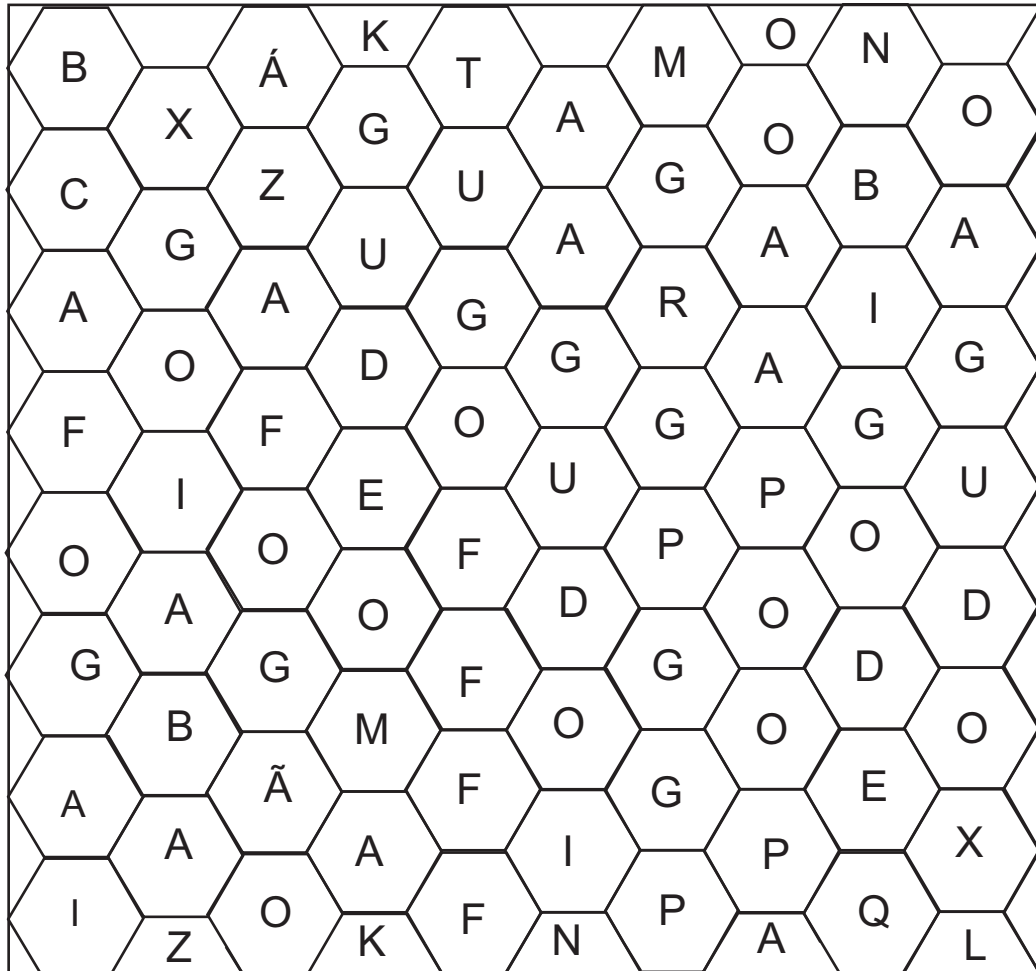

GUDE	FIGO	GOIABA	FOGO
BIGODE	AGUDO	GAGO	AFOGA
GADO	FOGÃO	FUGA	ÁGUA

AUTODITADO
OLHO VIVO! ESCREVA PALAVRAS QUE TENHAM
SÍLABAS DA FAMÍLIA DA LETRA **G**.

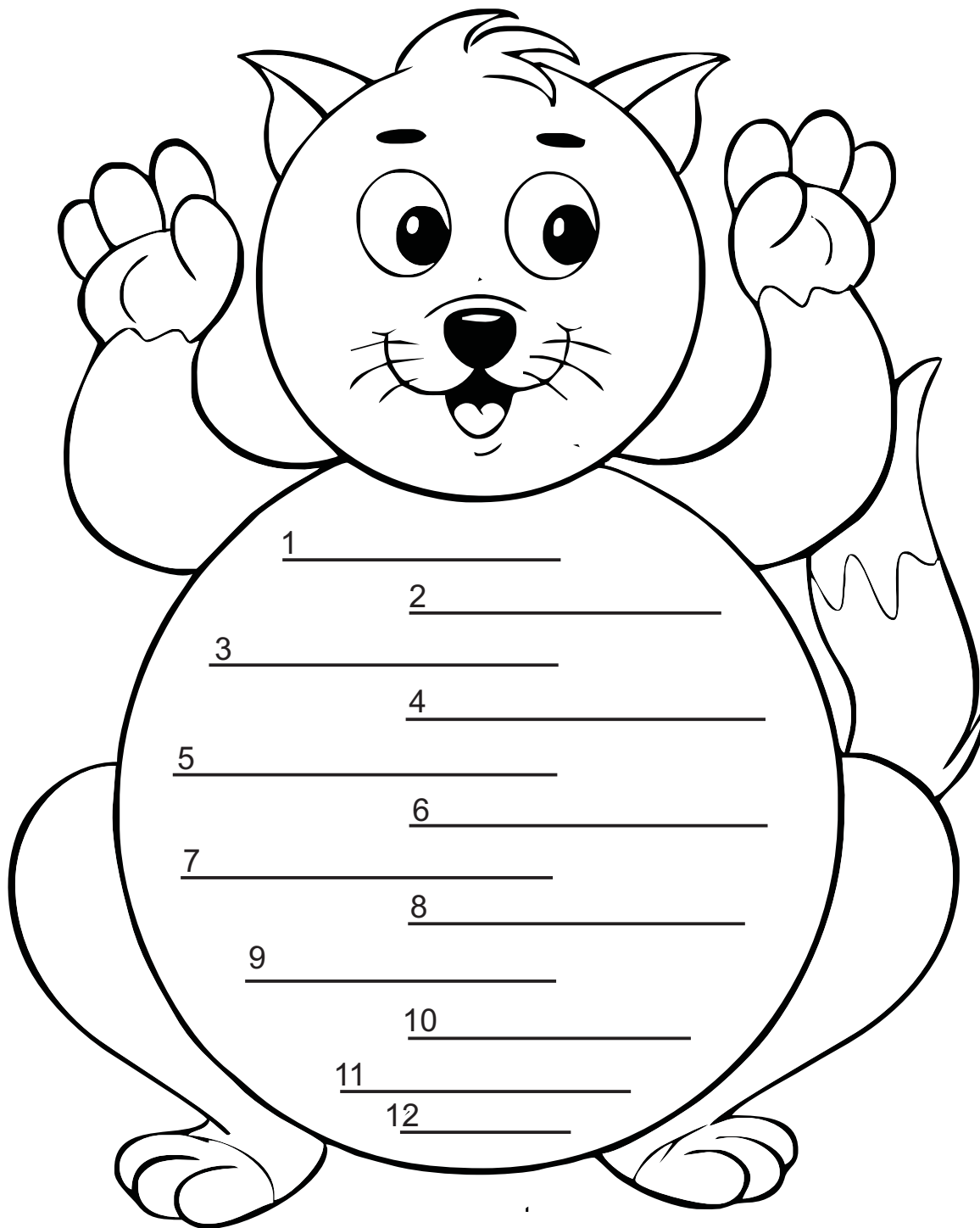

DITADO
ESCREVA AS PALAVRAS COM ATENÇÃO.

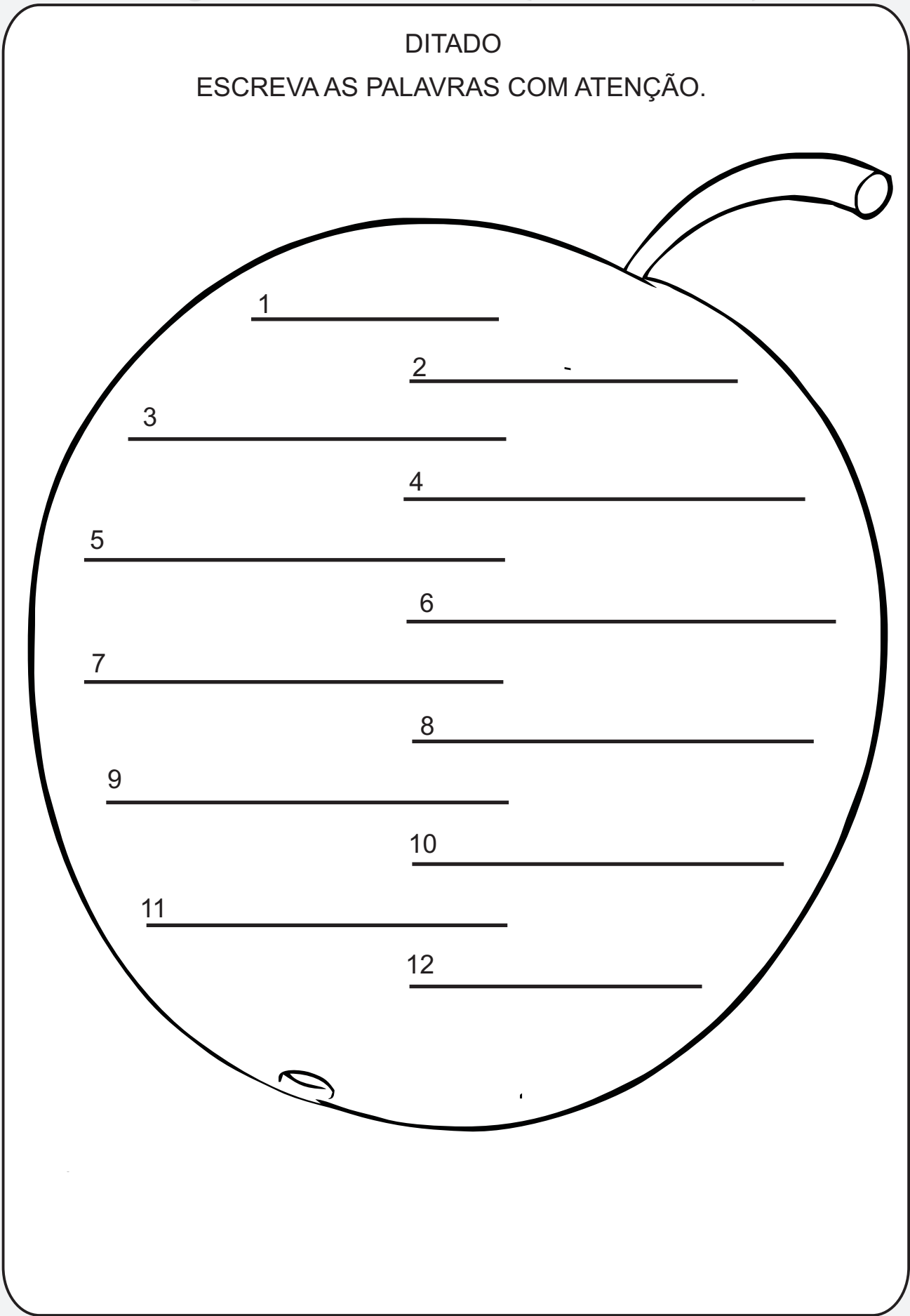

a q u b A C S z m X N O p c g V
p
c
v
o
g
s
a
s
u
D
q
N
G
h
c
b v h a B q A C u z m o X

JACARÉ NA LAGOA

JACARÉ PESCANDO NA LAGOA } 2X

VIU UM PEIXINHO

ABRIU A BOCA.

NHOC, NHOC, NHOC!



Cantigas Infantis, Ed. Ciranda Cultural, Pág. 99

CIRCULE NO TEXTO A PALAVRA **JACARÉ**.

COPIE A PALAVRA JACARÉ.

jacaré -

jacaré -

COPIE A LETRA **j-J**.

j - j - j - j - j - j -

j - j - j - j - j - j -

J - J - J - J - J - J

J - J - J - J - J - J -

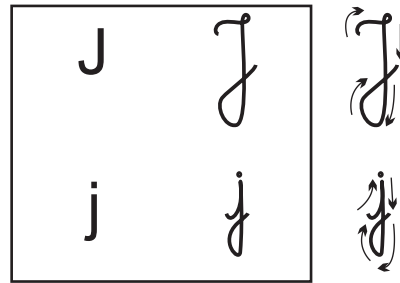
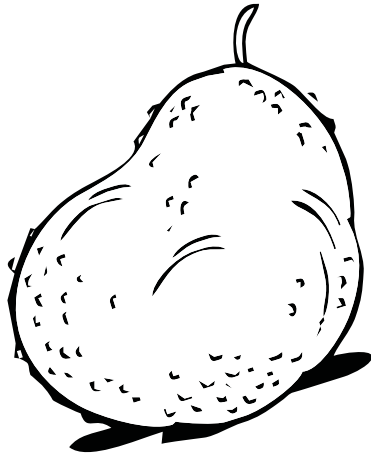

JUNTE A LETRA **J-j** COM AS VOGAIS E FORME A FAMÍLIA SILÁBICA.

+	A	E	I	O	U
J					

COPIE.

JA - JE - JI - JO - JU -

ja - je - ji - jo - ju -

+	a	e	i	o	u	ão
j						

ja - je - ji - jo - jão

ja - je - ji - jo - ju - jão

j - J - j - J

ja - Ja - je - Je - ji - Ji - jo - Jo - ju - Ju - jão

LEIA AS PALAVRAS QUE JOÃO PENSOU EM ESCREVER. DEPOIS, COPIE-AS SEPARANDO NOS QUADROS DE ACORDO COM A SÍLABA INDICADA.



JA	JE	JI	JO
	JU	JÃO	

COPIE AS PALAVRAS E ESCREVA O NÚMERO DE SÍLABAS CORRESPONDENTES.

JENIPAPO

JIPE

JACA

JUJUBA

BOTIJÃO

BEIJU

AJUDE O JUCAA COMPLETAR AS FICHAS.

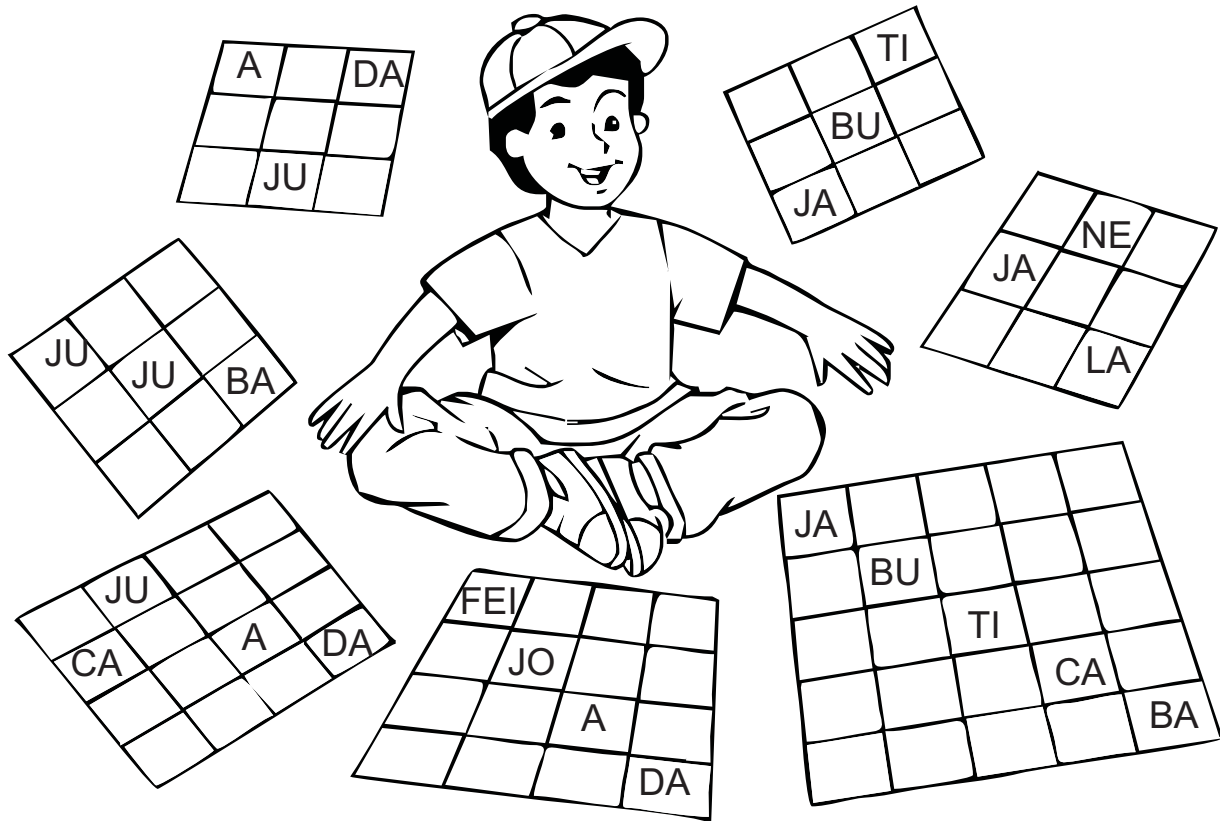

COMPLETE AS PALAVRAS COM AS SÍLABAS:
JA, JE, JI, JO, JU, JÃO. DEPOIS
COPIE E SEPRE AS SÍLABAS.



___ CA

--	--



FEI ___

--	--

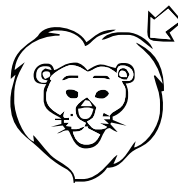

___ BA

--	--



CA ___

--	--



JU ___ BA

--	--	--



___ PE

--	--



___ CA

--	--



___ CARÉ

--	--	--

COMPLETE AS PALAVRAS COM
UMA DAS SÍLABAS E DEPOIS COPIE-AS.

__CA JA
__BÁ JU

BEI__ JO
BEI__ JU











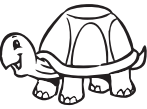
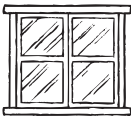

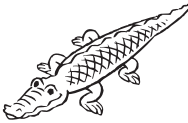







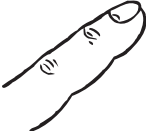



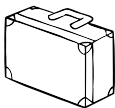

__BÓIA JO
__ÃO JI

CA__ JA
__NELA JU

__BUTI JA
__CA JO









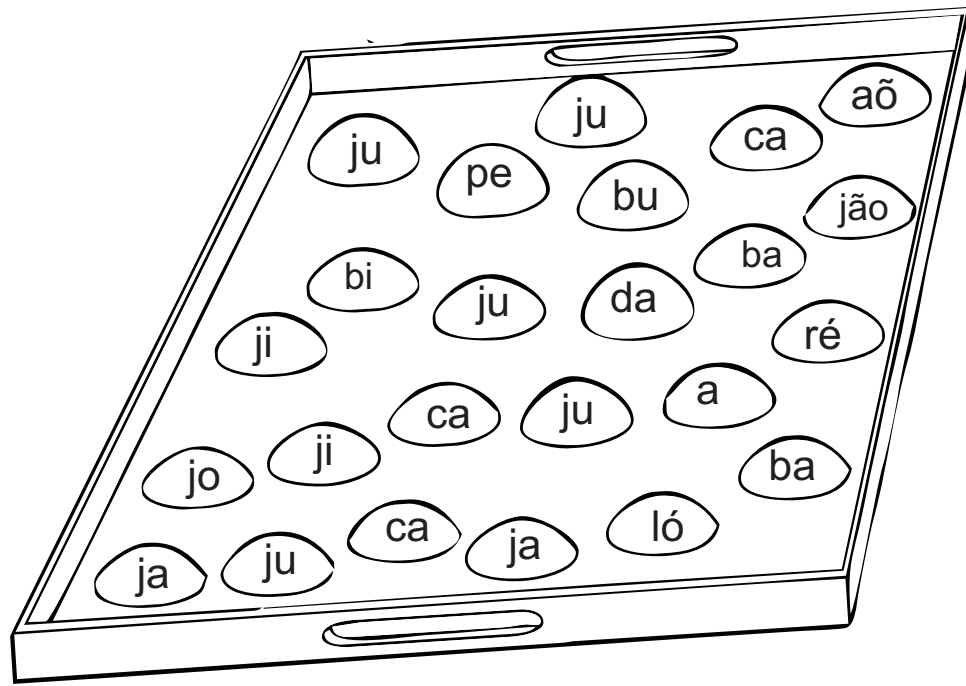

FEI__ JÃO
__BA JU

PINTE OS DESENHOS CUJOS
NOMES TÊM A SÍLABA INDICADA.

JA					
JE					
JI					
JO					
JU					
JÃO					

LEIA AS SÍLABAS DAS JUJUBAS E PINTE-AS FORMANDO PALAVRAS. COPIE-AS ABAIXO DE ACORDO COM AS CORES QUE VOCÊ PINTOU.





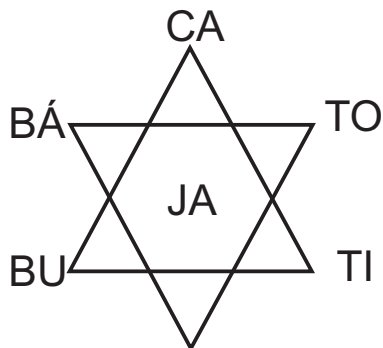

	_____		_____
	_____		_____
	_____		_____
	_____		_____
	_____		_____

FORME PALAVRAS COMEÇADAS COM A SÍLABA **JA**.



_____	_____
_____	_____
_____	_____

ESCREVA O TRAVA-LÍNGUA SUBSTITUINDO OS DESENHOS PELAS PALAVRAS.

O		DO JUCA E A		DO CAJÁ.
O		DO JUJU E O		DO CACÁ.

LEIA AS SÍLABAS, DEPOIS ESCREVA AS PALAVRAS DE ACORDO COM OS NÚMEROS.

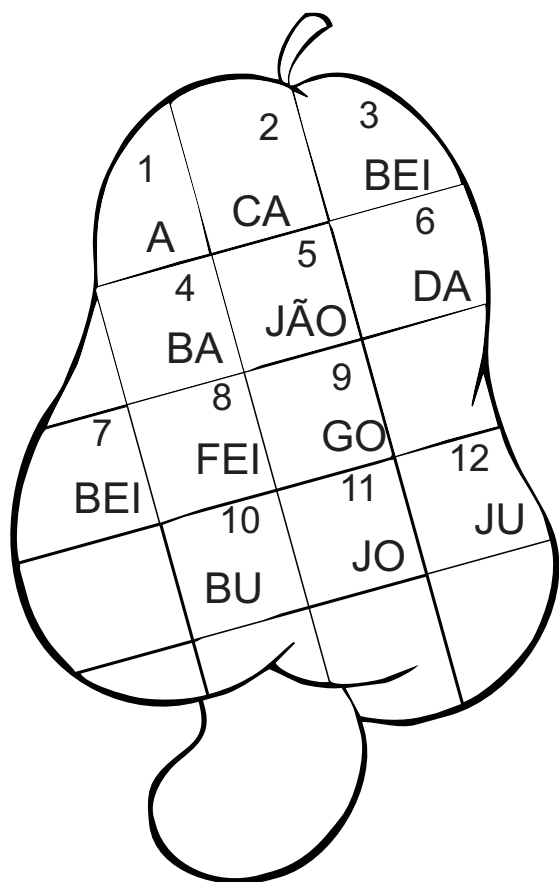

12-12-4	7-11
10-5	8-5
8-11-1-6	1-12-6
11-9	3-12
12-4	12-2
2-12	2-12-1-6

ADIVINHE:
VERDE NASCI, BRANCO É MEU ESTADO, VISTO-ME DE LUTO PARA MORRER ARREBENTADA. QUEM SOU?

(JABUTICABA)

COMPLETE AS FRASES COM AS PALAVRAS ADEQUADAS.

JEITO

JUJUBA

PIJAMA

O _____ DE JÚLIO É NOVO.

CAJADO

LOJA

BEIJO

JUCA AJUDA O PAPAÍ NA _____.

JOGO

JUBA

JABUTICABA

VOVÓ FEZ DOCE DE _____.

CAJUADA

JOGO

JUJUBA

JÚLIA COMEU TODA A _____ DO PACOTE.

MAMÃE FOI AO MERCADO E COMPROU SOMENTE
PRODUTOS COM JA, JE, JI, JO, JU, JÃO.
PINTE-OS E DEPOIS ESCREVA OS NOMES.

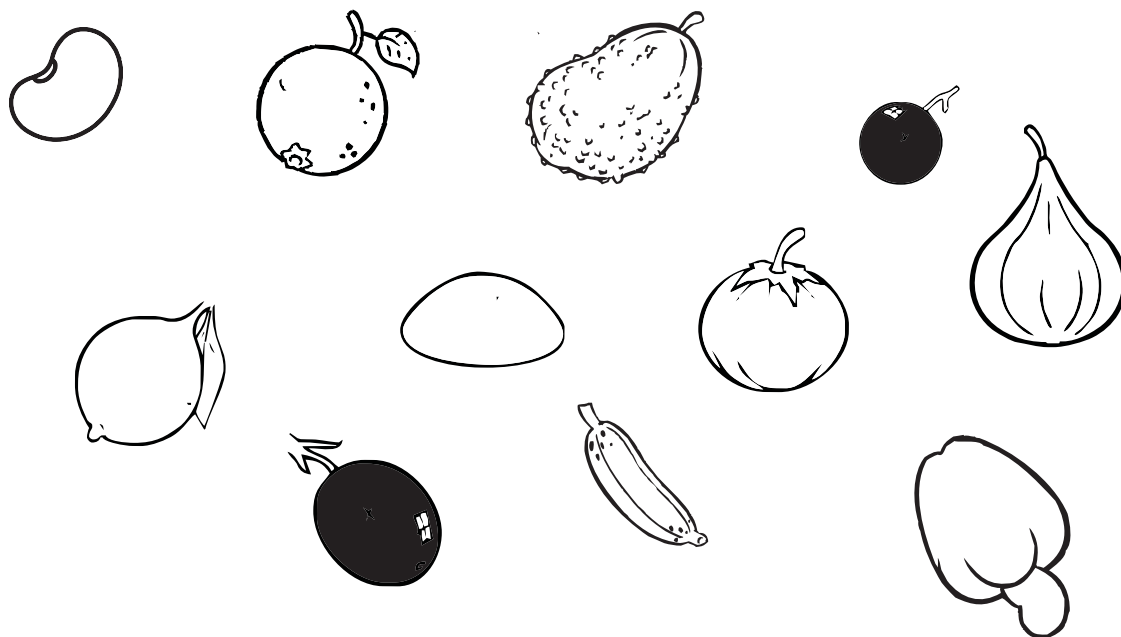

DESCUBRA O SEGREDO E CONTINUE.

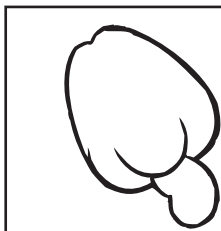

CAJU



CAJUADA

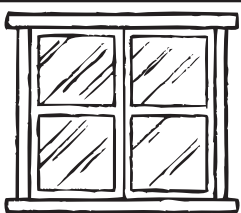

JANELA

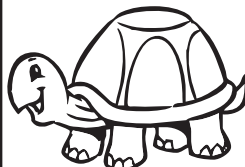

JABUTI

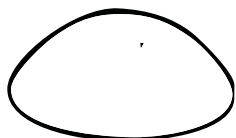

JUJUBA



JIPE

COMPLETE AS PALAVRAS ABAIXO COM AS SÍLABAS.

ja - je - ji - jo - ju - jão

_____ ULA _____ CA _____ BÓIA
 _____ GO JU _____ BA FU _____
 _____ PE _____ BUTI CA _____
 FEI _____ CA _____ ADA FEI _____ ADA
 A _____ DA BEI _____ BEI _____

ESCREVA O NOME DAS FRUTAS NA CRUZADINHA E ESCREVA AS PALAVRAS.

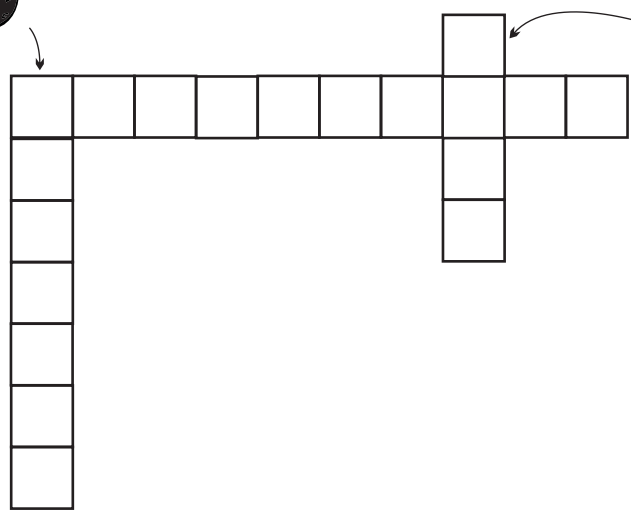

a q u b A C S Z m X N O P C G V

CIRCULE AS SÍLABAS QUE FORMAM OS NOMES DOS DESENHOS E DEPOIS ESCREVA AS PALAVRAS.



O JA
CA
JU DE

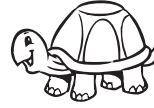

FA DO
BU JA
TI CO

BA BU
JA BI
TI CA



RÉ DA
CA
FA JA
BA



BÃO
FEI JÃO
DÃO SÃO



JU CA
FA BO
JA DO

NUMERE AS PALAVRAS DE ACORDO COM O NÚMERO DOS DESENHOS.

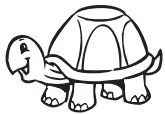

1

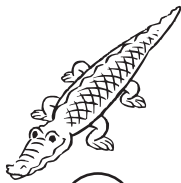

2



3



4



5



7



6



9



8



10

- JABUTI
- JACÁ
- JIPE
- BEIJO
- JACA
- CAJU
- JACARÉ
- JIBÓIA
- FEIJÃO
- JAMELÃO

C b v H a B q A C u z m O X

COMPLETE COM **G** OU **J** AS
PALAVRAS DO DESENHO. DEPOIS
COPIE-AS SEPARANDO EM SÍLABAS.

___ALO	___ACA	___OLA
___EITO	___UCA	___ATO
___ANELA	CA___U	___IPE
FO___ÃO	___BUTICABA	___ACÁ
___ABUTI	FÍ___ADO	FI___O

□	□	□	□	□	□	□	□	□
□	□	□	□		□	□	□	□
□	□	□	□		□	□	□	□
□	□	□	□	□	□	□	□	□

LEIA AS PALAVRAS E CIRCULE
A SÍLABA REPETIDA EM CADA QUADRO.

CAJADO JAMELÃO CORUJA JABUTI	JEOVÁ JENIPAPO JECA JEITO	JIBÓIA JIPE JILÓ JIA
---------------------------------------	------------------------------------	-------------------------------

JÓIA JOÃO	JOGO FEIJODA	JUJUBA CAJU	JUCA CAJUADA
--------------	-----------------	----------------	-----------------

ADIVINHE.
TEM LOMBO DE PORCO, TEM ORELHA DE PORCO,
TEM COSTELA DE PORCO, MESMO ASSIM NÃO É PORCO.

(FEIJOADA)

DESCUBRA O SEGREDO ESCRREVENDO
AS PALAVRAS NOS QUADROS.

GATO	GAMELA
JIBÓIA	JAMELÃO
GULA	BEIJU
BEIJO	GUGA
GOIABA	JUJUBA
JOGO	GAGO
JUJU	GUDE
GOTA	JABUTI

G

_____	_____
_____	_____
_____	_____
_____	_____

J

_____	_____
_____	_____
_____	_____
_____	_____

LEIA AS PALAVRAS ABAIXO E DEPOIS
COPIE-AS ESCRREVENDO DE ACORDO
COM O NÚMERO DE SÍLABAS.

<i>cajado</i>	<i>juba</i>	beijo	janela	jabuti	<i>caju</i>	
JUCA		feijoada	<i>cajuada</i>	jenipapo	jiló	
		jabuticaba	<i>jaleco</i>	jacaré		

2 SÍLABAS

3 SÍLABAS

4 SÍLABAS

5 SÍLABAS

CAÇA-PALAVRAS

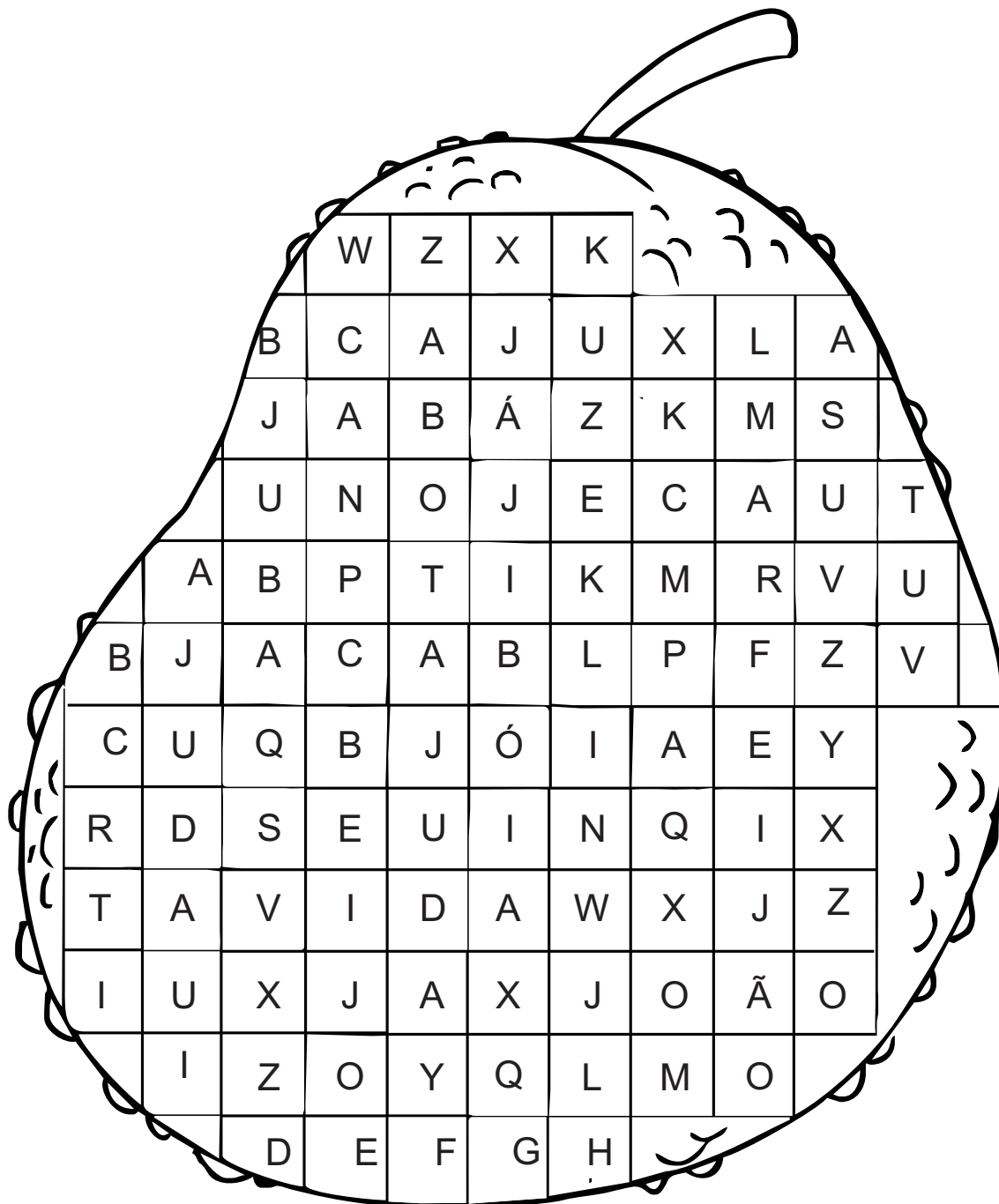

AJUDA	JABÁ	JIBÓIA	JECA
JÓIA	JUBA	JACA	CAJU
FEIJÃO	JOÃO	JUDA	BEIJO

AUTODITADO

ESCREVA PALAVRAS QUE TENHAM
SÍLABAS DA FAMÍLIA DA LETRA **J**.

1-	7-
2-	8-
3-	9-
4-	10-
5-	11-
6-	12-

HORA DO DITADO
ATENÇÃO É HORA DE ESCREVER CORRETAMENTE.

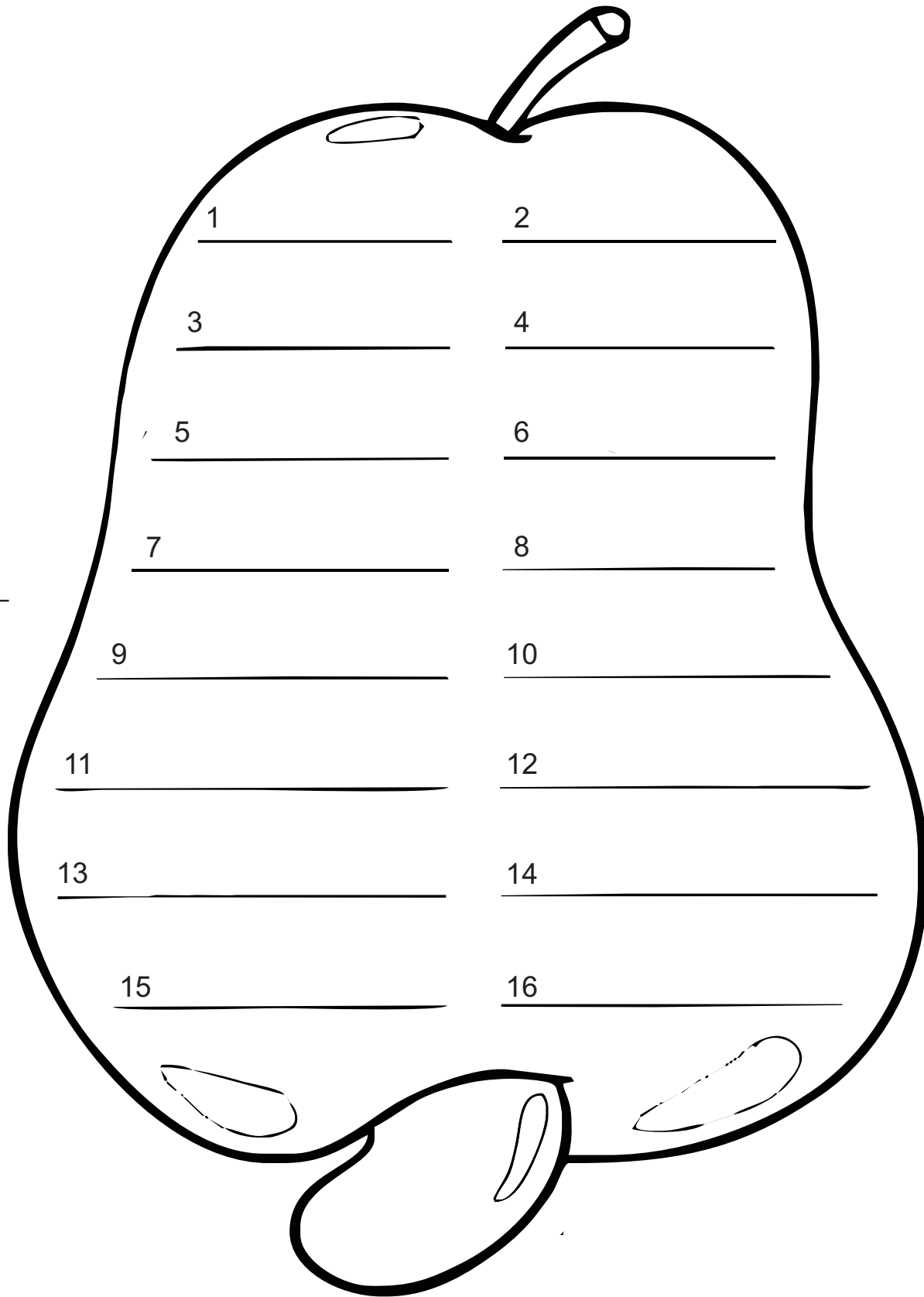

MEU LIMÃO, MEU LIMOEIRO

MEU LIMÃO, MEU LIMOEIRO
MEU PÉ DE JACARANDÁ.
UMA VEZ TINDOLELÊ
OUTRA VEZ TINDOLALÁ.

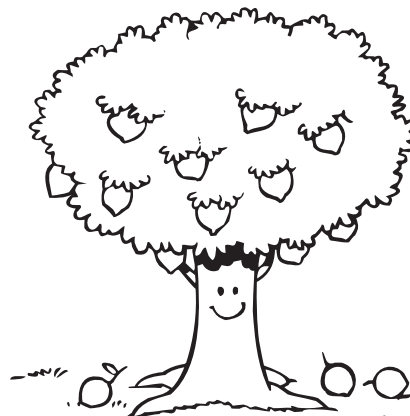

As Mais Belas Cantigas de Roda,
Ciranda Cultural, pág. 40.

CIRCULE NO TEXTO AS
PALAVRAS QUE TÊM A LETRA **L**.

COPIE.

limão

limão

COPIE A LETRA **L**.

L

L

la - le - li - lo - lu - lã

la - le - li - lo - lu - lã

la - le - li - lo - lu

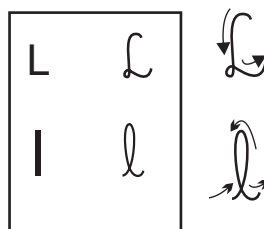
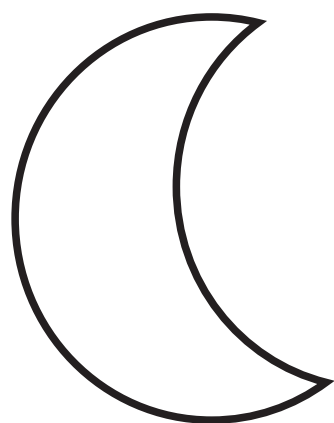

JUNTE A LETRA **L-I** COM AS VOGAIS
E FORME A FAMÍLIA SILÁBICA.

+	A	E	I	O	U
L					

COPIE.

LA - LE - LI - LO - LU

La - le - li - lo - lu

+	a	e	i	o	u	ão
l						

la - le - li - lo - lu - lã

la - le - li - lo - lu - lã

a q u b A C S Z m X N O P C G V

PINTE A LETRA **L-I** NAS PALAVRAS ABAIXO.

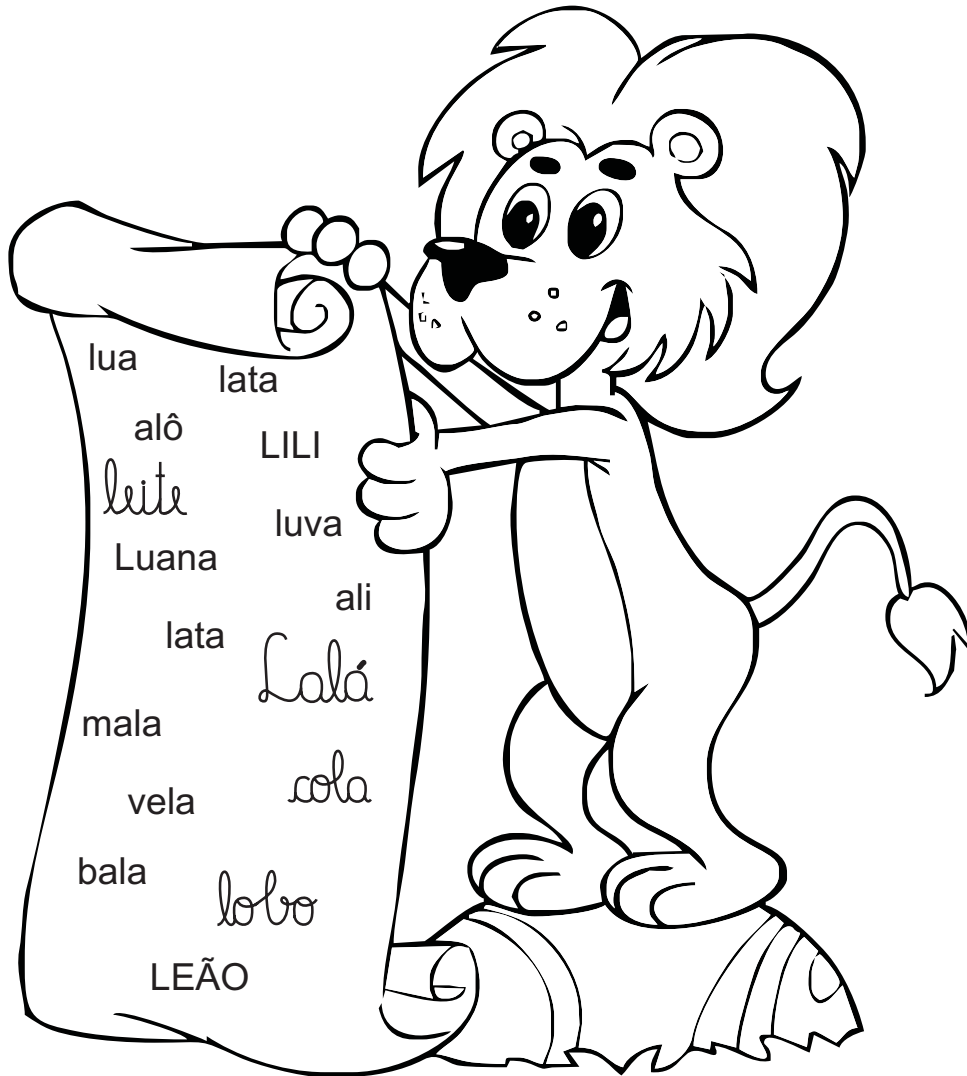

JUNTE A LETRA **L-I** ÀS VOGAIS E FORME A FAMÍLIA SILÁBICA.

C b v h A B q A C u z m O X

OBSERVE OS DESENHOS E COMPLETE AS SÍLABAS QUE FALTAM NAS PALAVRAS.

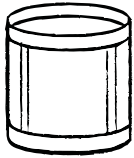

	TA
--	----

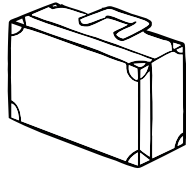

MA	
----	--



	GO
--	----

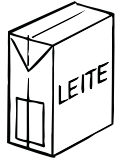

	TE
--	----



	ÃO
--	----



	BO
--	----



	A
--	---

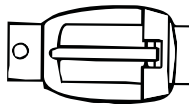

FI	VE	
----	----	--

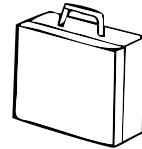

MA		TA
----	--	----

TROQUE AS SÍLABAS DE LUGAR E FORME OUTRAS PALAVRAS.

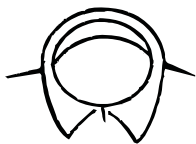

GO	LA

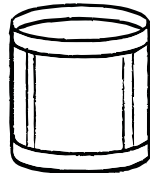

LA	TA

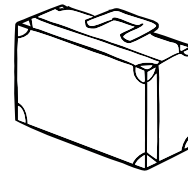

MA	LA



LO	BO

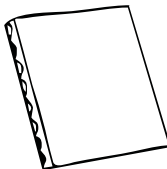

TE	LA



VE	LA

JUNTE AS FIGURAS IGUAIS E FORME PALAVRAS.

CO LU LO LU LA LI

MÃO LA PA JA A GO

FAÇA UM X NO NOME QUE CORRESPONDE AO DESENHO.



- LUVA
- LUPA
- LUA



- LEÃO
- LEITE
- LEVE



- LIMÃO
- LIGA
- LILI



- LOJA
- LOBO
- LOUCO

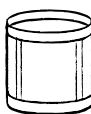

- LAMA
- LAVA
- LATA



- FACÃO
- LOBÃO
- BALÃO































- LEITE
- CALA
- LUVA



- NOVELO
- BULE
- FILA

SUBSTITUA OS SÍMBOLOS PELAS SÍLABAS E FORME PALAVRAS.

								
LU	LI	LO	MÃO	GO	A	MA	LA	BO

		_____			_____
		_____			_____
		_____			_____
		_____			_____
		_____			_____

CIRCULE AS PALAVRAS QUE TÊM A SÍLABA INDICADA NA PRIMEIRA COLUNA.

LA	LAMA	PANELA	BALÉ	LATA	BOLA
LE	LEITE	LARANJA	MALETA	VELA	LEÃO
LI	LIMÃO	LIGA	LAÇO	LIBÉLULA	LUVA
LO	LOTO	LIXO	BULE	NOVELO	LOJA
LU	LUA	FALA	LUVA	LIA	LUTA
LÃO	BALÃO	DEDÃO	SALÃO	FOGÃO	SALÃO

LEIA, COMPLETE A PALAVRA E
LIGUE O NOME AO DESENHO.

LAGOA

CABE__



CABELO

BA__IA



BALEIA

__GOA



LOBO

GAIO__



LUA

__BO



GAIOLA

__A



JUNTE AS SÍLABAS E FORME PALAVRAS
ESCREVENDO-AS NO QUADRO.

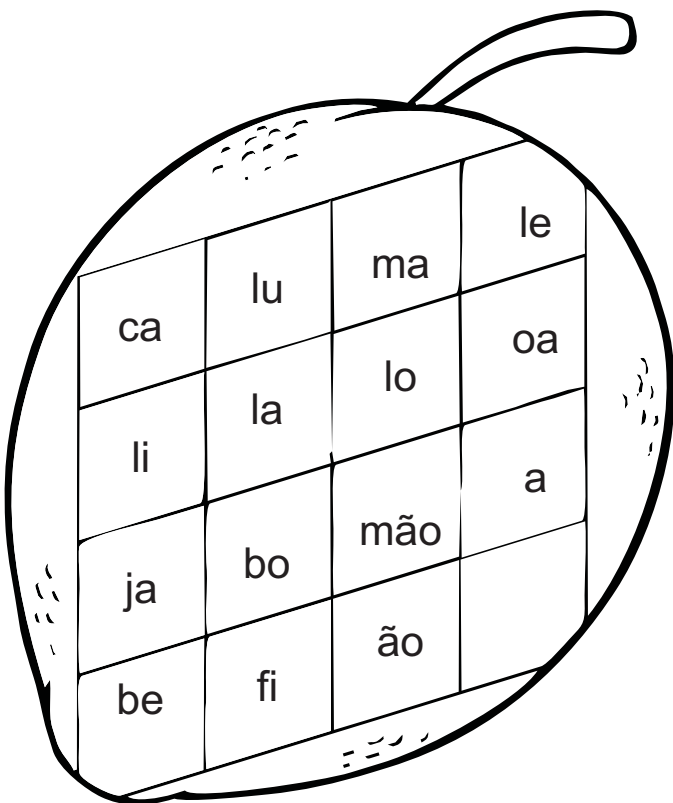

a q u b A C S z m X N O p c G V

LEIA AS PALAVRAS E DEPOIS
ESCREVA-AS NO DOMINOX.

PANELA
MALA
LÃ
LUPA
LEÃO
LUA
LOBO
ALÔ

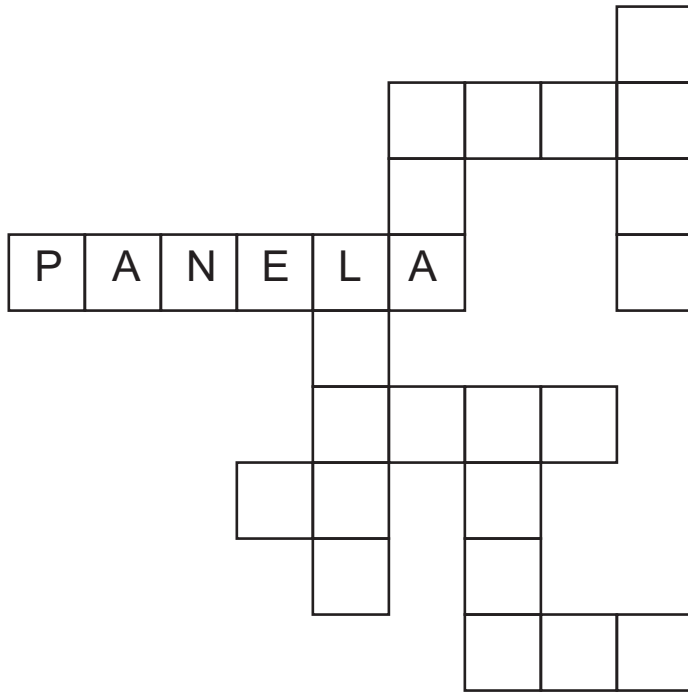

PINTE AS SÍLABAS QUE FORMAM OS NOMES
DOS DESENHOS E DEPOIS COPIE AS PALAVRAS.

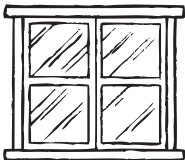

JA PA NE PO LA



A FA LU JA



BO GO CO LA

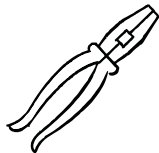

ME A LI CA TE



FO CO LO LA



BU DU LE FU



LU BA PA TA

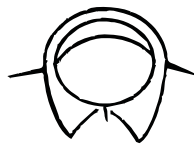

CO GO DO LA



LE CÃO ÃO BO

C b v H a B q A C u z m O X

LIGUE AS FIGURAS AO NOME CORRESPONDENTE.

LUA

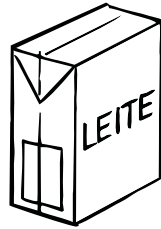

PANELA

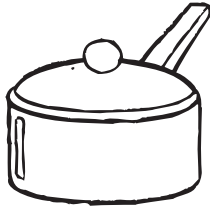

LAGO

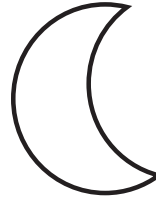

LEITE

MALA



LUPA

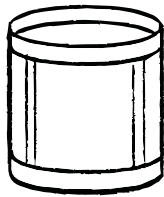
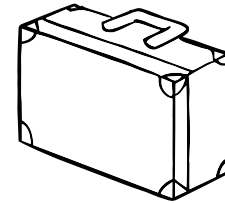

LUVA



LOBO

LEÃO



LATA

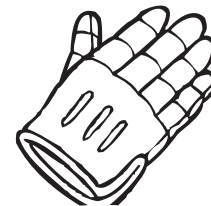

COPIE AS PALAVRAS REFERENTES AOS DESENHOS.

COMPLETE AS PALAVRAS COM AS SÍLABAS QUE FALTAM. ELAS PERTENCEM À FAMÍLIA SILÁBICA DA LETRA **L**.

__A	__TA	MA__
__PA	__ÃO	__VA
__BO	PANE__	__JA
__GO	FO__A	PE__
PU__	__MA	FI__

SEPARE AS SÍLABAS DAS PALAVRAS E DEPOIS COPIE-AS.

PANELA		

GADO	

LEITE	

CABELO		

BALÃO	

BOLADA		

COMPLETE AS FRASES COM AS PALAVRAS QUE VOCÊ ESCREVEU.

NÃO DEVEMOS SOLTAR _____.

MAMÃE FEZ DOCE DE _____.

NA _____ TEM FEIJOADA.

O _____ BICOU O DEDO DE JUJU.

O MENINO LEVOU UMA _____ NO JOELHO.

LUANA CORTOU O _____.

LIGUE AS SÍLABAS FORMANDO PALAVRAS.

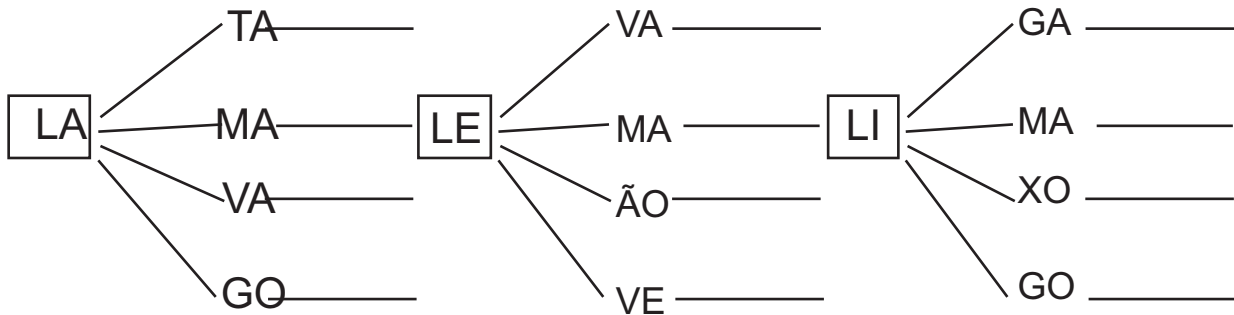

ADIVINHE.

MESMO PERTINHO DO CÉU, EM CASA MORA TRANCADA. QUER
CHOVA, QUER FAÇA SOL VIVE SOZINHA E MOLHADA.

(A LÍNGUA)

CAÇA-PALAVRAS

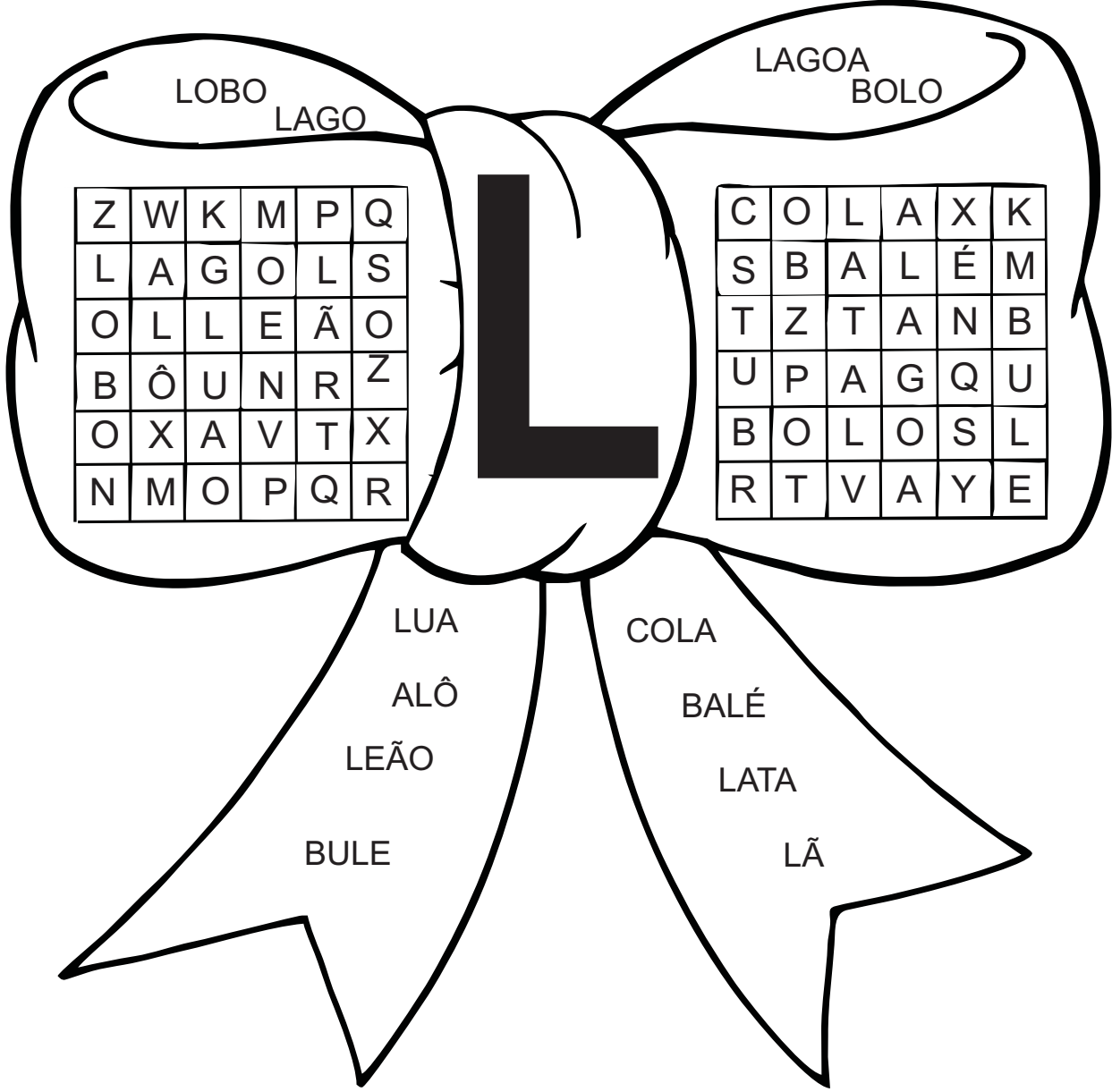

HORA DO DITADO

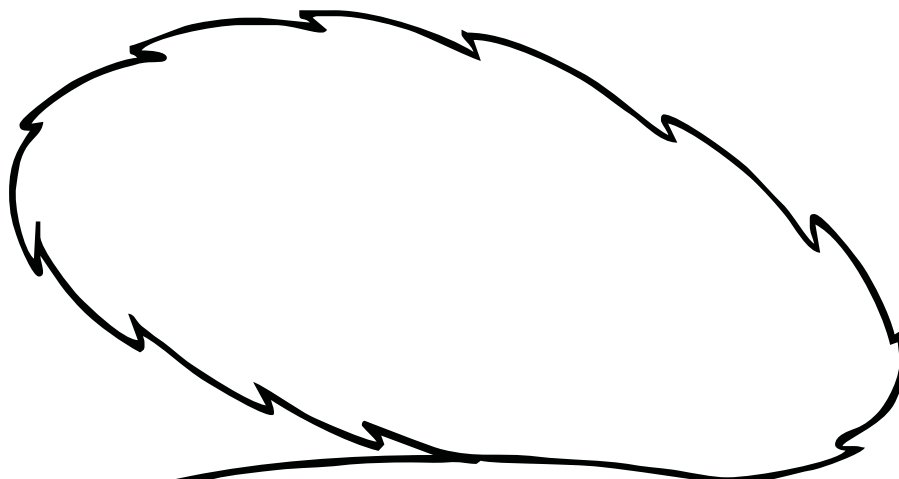

1	2
3	4
5	6
7	8
9	10
11	12

AUTODITADO
ESCREVA PALAVRAS COM
SÍLABAS DA FAMÍLIA DA LETRA **L**.



a q u b A C S Z m X N O P C G V
p
c
v
o
g
s
a
s
u
D
q
N
G
C
h
C b v H a B q A C u z m O X

ANQUINHAS

A MODA DAS TAIS ANQUINHAS,
É UMA MODA ENGRAÇADA.
DEPOIS DE JOELHOS EM TERRA,
FAZ A GENTE FICAR PASMADA

MARIA, SACODE A SAIA,
MARIA, LEVANTA OS BRAÇOS.
MARIA, TEM DÓ DE MIM,
MARIA, ME DÁ UM ABRAÇO.



Cantigas Infantis, Ed. Ciranda Cultural, pág. 25.

ASSINALE NO TEXTO AS
PALAVRAS QUE TÊM A LETRA **M-m**.

COPIE.

moda

moda

Maria

Maria

m -

m -

PINTE A LETRA **M-m** NAS PALAVRAS DO DESENHO.

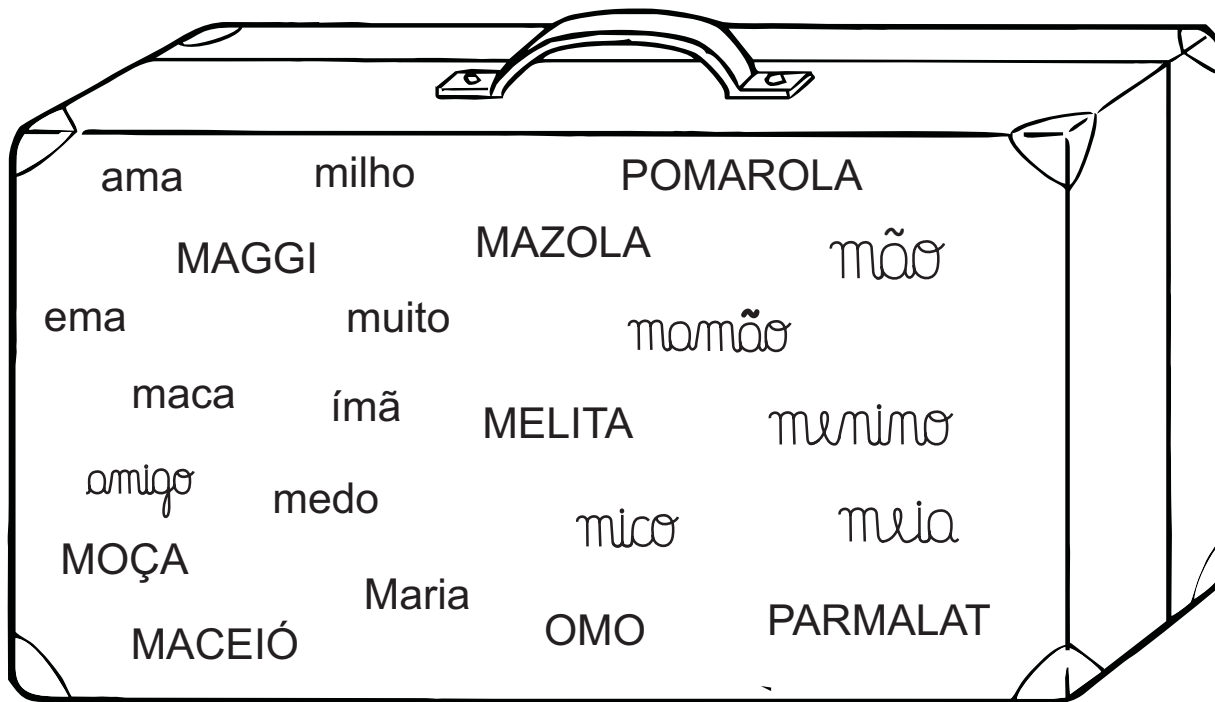

JUNTE A LETRA **M-m** COM AS VOGAIS, FORME A FAMÍLIA SILÁBICA E COPIE-AS.

m

a _____

e _____

i _____

o _____

u _____

M

a _____

e _____

i _____

o _____

u _____

COPIE.

ma-me-mi-mo-mu-mão

Ma-Me-Mi-Mo-Mu

JUNTE A LETRA **M-m** E FORME PALAVRAS,
ESCREVA-AS EMBAIXO DA FICHA.

__ofo

__ara

__aria

li__ão

m-M

__ãe

Ca__ila

__oeda

co__e

PINTE AS SÍLABAS QUE FORMAM OS NOMES DOS
DESENHOS, DEPOIS COPIE A PALAVRA FORMADA.

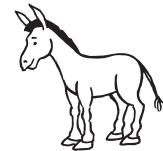
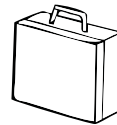

MO	LE	E	BO	DA
----	----	---	----	----

BU	MA	CA	LE	TA
----	----	----	----	----

MU	FA
DU	LA

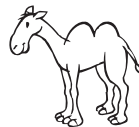

CA	MO
LA	BA

CA	DA	ME
BE	LO	DO

MA	BO	CO
DU	CA	LA

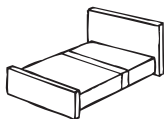

CA	BA	FA
BO	MA	DO

BÃO	MÃO
MA	CA

LI	CÃO
DA	MÃO

COPIE AS PALAVRAS NO QUADRO DE ACORDO COM A SÍLABA INDICADA.

MALA	MEDO	MIADO	COMIDA	FOME
MOLA	MATA	MENINA	MODA	MAGO
MULA	MICO	MACA	MUDO	MIAU
MOEDA	MULATO	MOTO	MESA	MUDA

MA	ME	MI	MO	MU
_____	_____	_____	_____	_____
_____	_____	_____	_____	_____
_____	_____	_____	_____	_____
_____	_____	_____	_____	_____

ESCREVA O NOME DOS DESENHOS.

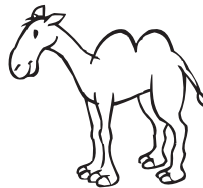
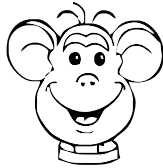
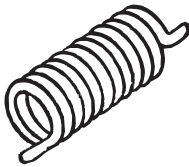

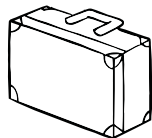

ORDENE AS SÍLABAS E FORME PALAVRAS.

4	2	1	3
DA	MO	LI	NA

2	3	1
TO	CA	MO

2	1	3
ME	CA	LO

3	1	2
DO	MI	A

1	3	2
MO	DA	E

3	2	1
TE	MA	TO

2	1	3
NI	ME	NO

3	1	2
TA	MA	LE

3	2	1
JO	O	MI

a q u b A C S z m X N O p c G V

LIGUE A FIGURA AO NOME.

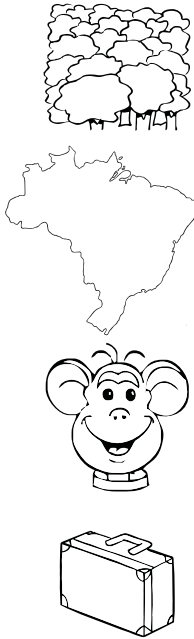

MAPA

MULA

MALA

MEIA

MATA

MAMÃO

MICO

MOEDA



COPIE AS PALAVRAS.

FORME PALAVRAS, JUNTANDO AS SÍLABAS DE ACORDO COM OS NÚMEROS.

1 CA	5 MA	9 LA
2 MO	6 ME	10 MU
3 ME	7 MI	11 LO
4 SA	8 DO	12 TA

1-6-11	6-9-8
_____	_____
6-8	1-3-9
_____	_____
10-9-12	10-8
_____	_____
10-9	1-7-4
_____	_____
2-9	9-5
_____	_____

C b v h A B q A C u z m O X

PINTE A PRIMEIRA SÍLABA, CONTE CINCO QUADRADINHOS E PINTE DA MESMA COR. DEPOIS, CONTE OUTROS CINCO E PINTE NOVAMENTE. VOCÊ FORMOU UMA PALAVRA COPIE-A NA LINHA. DESCUBRA AS OUTRAS PALAVRAS.

MA	MO	CA	TO	MA							
				CA	CO	ME	ME	MI	ME	MI	
_____				E	_____				NI		
_____				ME	_____				LA		
_____				MA	_____				O		
_____	LE	CO	DA	LO	TE	TA			NI		
								DA			
								NO	JO	DO	NA

COMPLETE AS PALAVRAS COM SÍLABAS DA FAMÍLIA DA LETRA **m-M**.

CA__	CA__DA	CA__LEÃO
__LA	__LADO	__TADE
__A	__ADO	__AU
__LA	__DA	__FO
__DO	__LATO	__LA

SEPRE AS SÍLABAS.

MALETA	<input type="text"/>	<input type="text"/>	<input type="text"/>	MULATA	<input type="text"/>	<input type="text"/>	<input type="text"/>	
CAMELO	<input type="text"/>	<input type="text"/>	<input type="text"/>	MULETA	<input type="text"/>	<input type="text"/>	<input type="text"/>	
POMADA	<input type="text"/>	<input type="text"/>	<input type="text"/>	LIMONADA	<input type="text"/>	<input type="text"/>	<input type="text"/>	<input type="text"/>
MELÃO	<input type="text"/>	<input type="text"/>	MAMÃO	<input type="text"/>	<input type="text"/>			
MOLA	<input type="text"/>	<input type="text"/>	CAMA	<input type="text"/>	<input type="text"/>			

FORME PALAVRAS COLORINDO AS SÍLABAS.
 PARA CADA PALAVRA FORMADA USE UMA COR.
 DEPOIS, COPIE AS PALAVRAS QUE VOCÊ FORMOU.

FORME PALAVRAS.

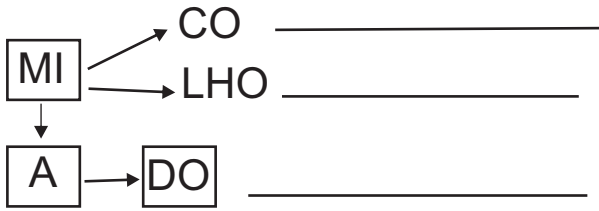
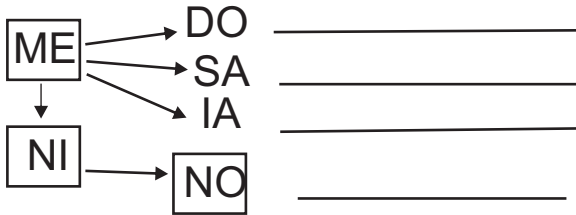
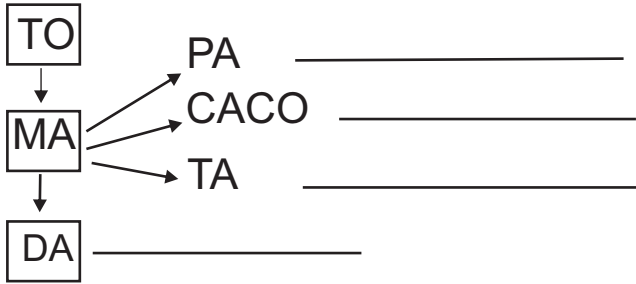

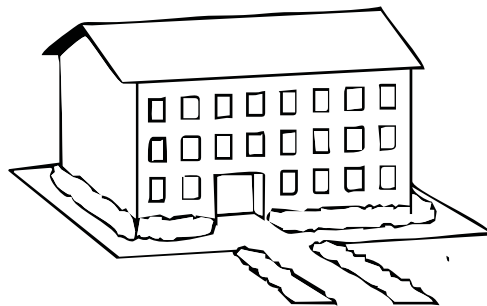
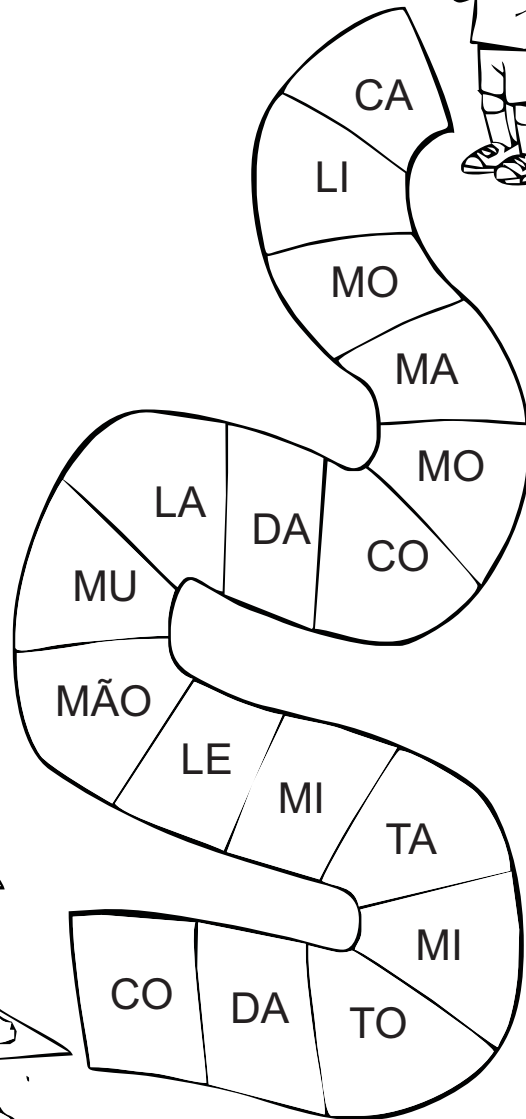

PINTE OS DESENHOS QUE INICIAM COM A MESMA SÍLABA.

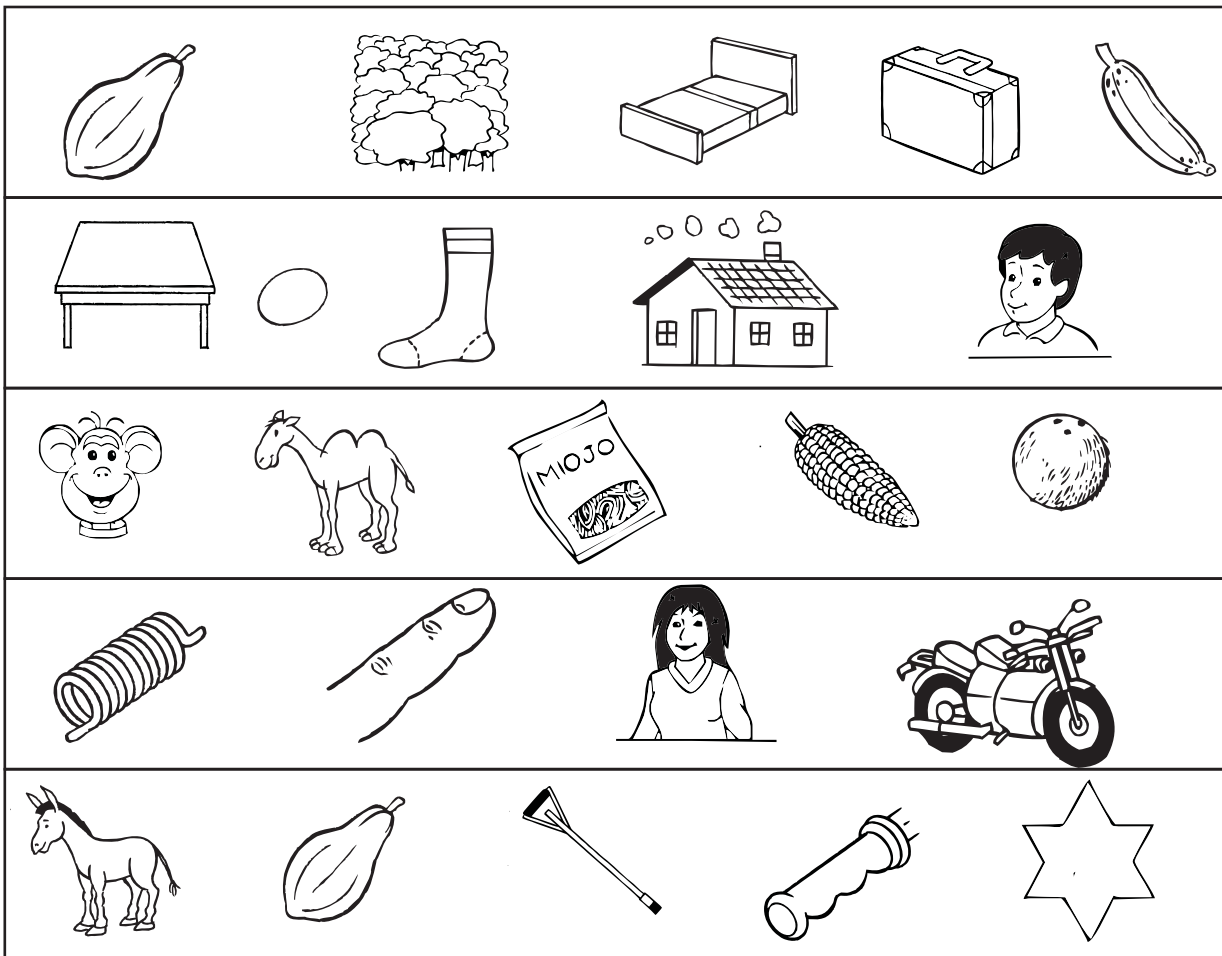

LEIA AS PALAVRAS E ESCREVA OUTRAS INICIADAS COM AS SÍLABAS CIRCULADAS.

(MU) LETA

(MO) DA

(MA) MÃO

(CO) MIDA

LI (MO) NADA

(ME) NINO

(MI) OJO

(ME) DO

LEIA AS PALAVRAS DO QUADRO. ESCREVA-AS SEPARANDO DE ACORDO COM O NÚMERO DE SÍLABAS.

MAMÃO	CAMA	CAMALEÃO	MALUCO
LIMONADA	AMIZADE	LIMÃO	MIOJO
MOLA	MOTUCA	CAMADA	MENINADA

2 SÍLABAS	3 SÍLABAS	4 SÍLABAS

JUNTE AS SÍLABAS EM DESTAQUE E FORME OUTRA PALAVRA. DESENHE A PALAVRA QUE VOCÊ FORMOU.

MO LA TO MA

GO MA CA MA

CO MA CO LA

MA LA LI MÃO

CA MELO MA TA

NUMERE OS DESENHOS DE ACORDO COM AS PALAVRAS.

- 1-MEIA
- 2-MIOJO
- 3-MACA
- 4-MICO
- 5-MOTO
- 6-MOLA
- 7-MESA
- 8-MALETA
- 9-MENINA

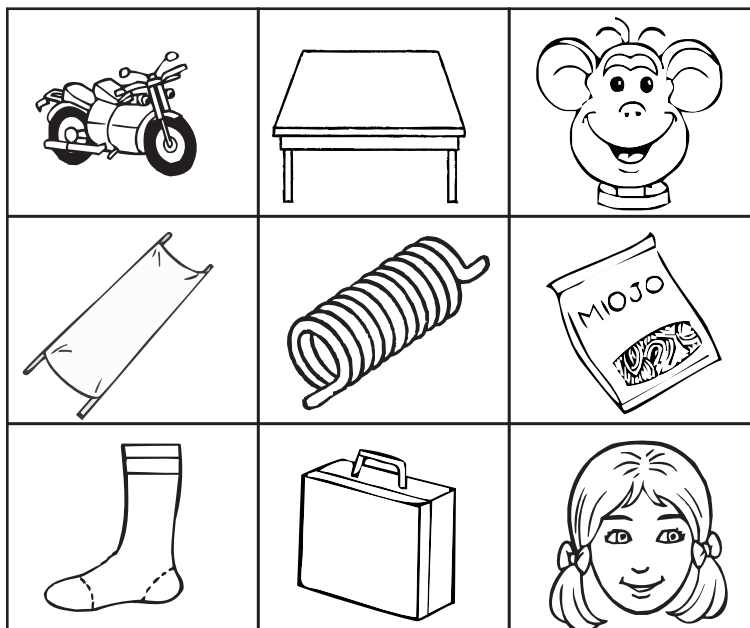

LIGUE OS DESENHOS QUE COMPLETAM AS FRASES.

A MACACA COME



O MENINO GOSTA DE COMER



PAPAI COMPROU UMA BONITA



O MICO PULA NA



JOÃO AMOLAA

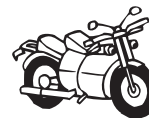

MARIA DÁ BANANA AO



LIGUE O DESENHO AO NOME CORRESPONDENTE.

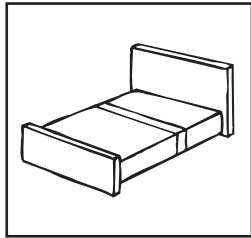

CASA
BANANA
CAMA

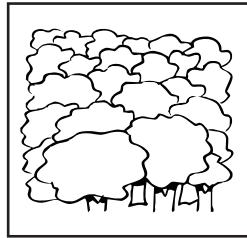

MALA
MATA
MACACO

MICO
MOLA
MEDO

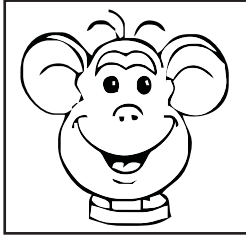

MACA
MIADO
MALETA

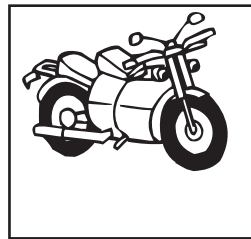
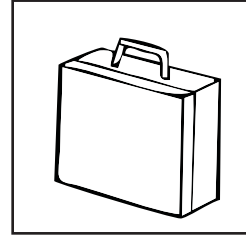

MOÇA
MOTO
MIAU

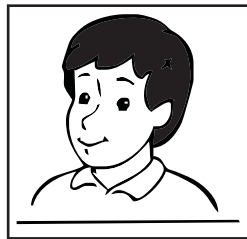

MESA
MENINO
MEIA

COPIE AS PALAVRAS NA SEGUNDA COLUNA E DEPOIS
ESCREVA OS NOMES DOS DESENHOS CORRESPONDENTES.

1ª

2ª

MEIA	
MENINO	
MALA	
MOTO	
MULA	
MATA	
MOLA	
MICO	
MIOJO	

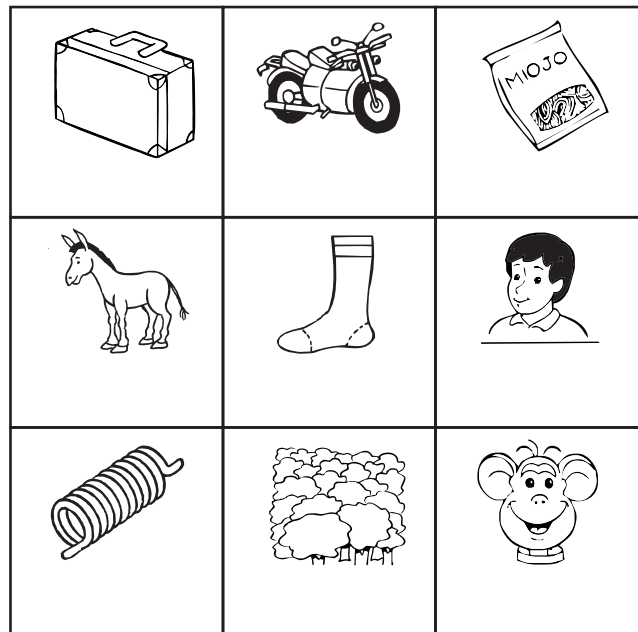



ADIVINHE.

ESTÁ NO MEIO DO COMEÇO, ESTÁ NO COMEÇO DO MEIO.
ESTANDO EM AMBOS, ESTÁ NA PONTA DO FIM?

(A LETRA M)

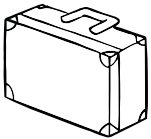
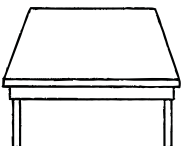
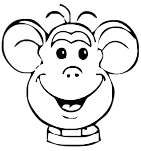
CIRCULE A PALAVRAS QUE INDICAM OS NOMES DOS DESENHOS.

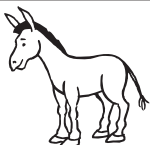
	MATO MALA MATE MACA
	MEDO MEIA MENINO MESA
	MICO MILHO MIAU MIOJO
	MOÇA MODA MOLA MOTO
	MUDA MULA MUVUCA MUDO

SUBSTITUA OS DESENHOS PELAS PALAVRAS E COPIE AS FRASES.

O  SAIU DA .

PAPAI VIAJOU E LEVOU A .

A  DO JUCA ESTÁ FURADA.

O  COMEU A BANANA DO .

ADIVINHE:

PODE SER GROSSA OU BEM FINA, ANDA SEMPRE PASSO-A-PASSO. EXISTE DE CORPO INTEIRO, MAS TEM NOME DE PEDAÇO.
(A MEIA)

CAÇA-PALAVRAS

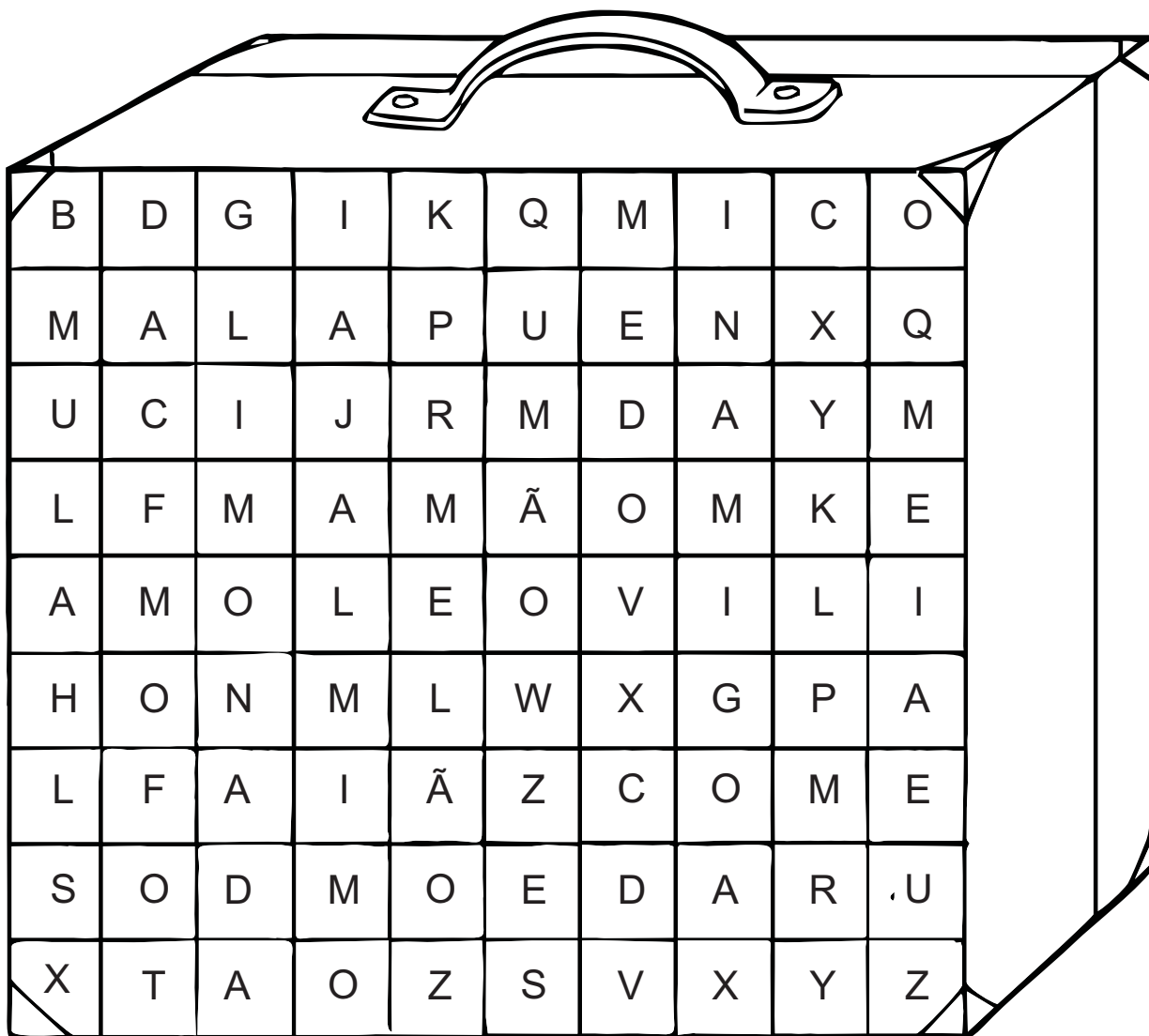

LIMONADA	MOEDA	MAMÃO	MULA	AMIGO
MÃO	MIMO	MALA	MICO	MEIA
MOLE	MELÃO	MEDO	MOFO	COME

a q u b A C S Z m X N O P C G V

AUTODITADO

VOCÊ JÁ SABE, É HORA DE ESCREVER PALAVRAS QUE TENHAM SÍLABAS DA FAMÍLIA DA LETRA **M**.

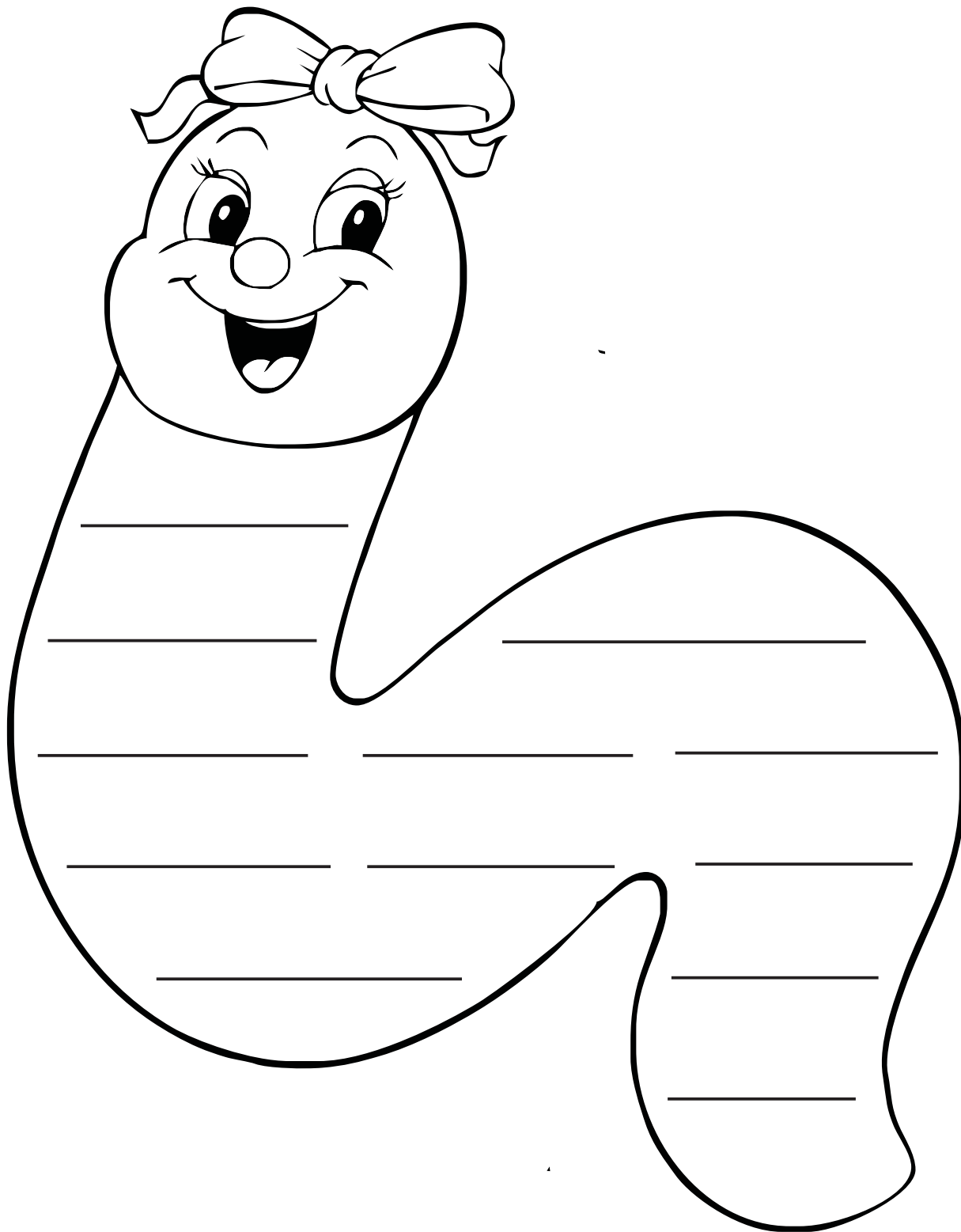

C b v H a B q A C u z m O X

a q u b A C S z m X N O p c G V

p
c
c
v
o
g
s
w
s
u
D
q
N
G
C
h

g
a
s
u
q
h
z
s
p
r
D
A
m
O
V
P
N

HORA DO DITADO

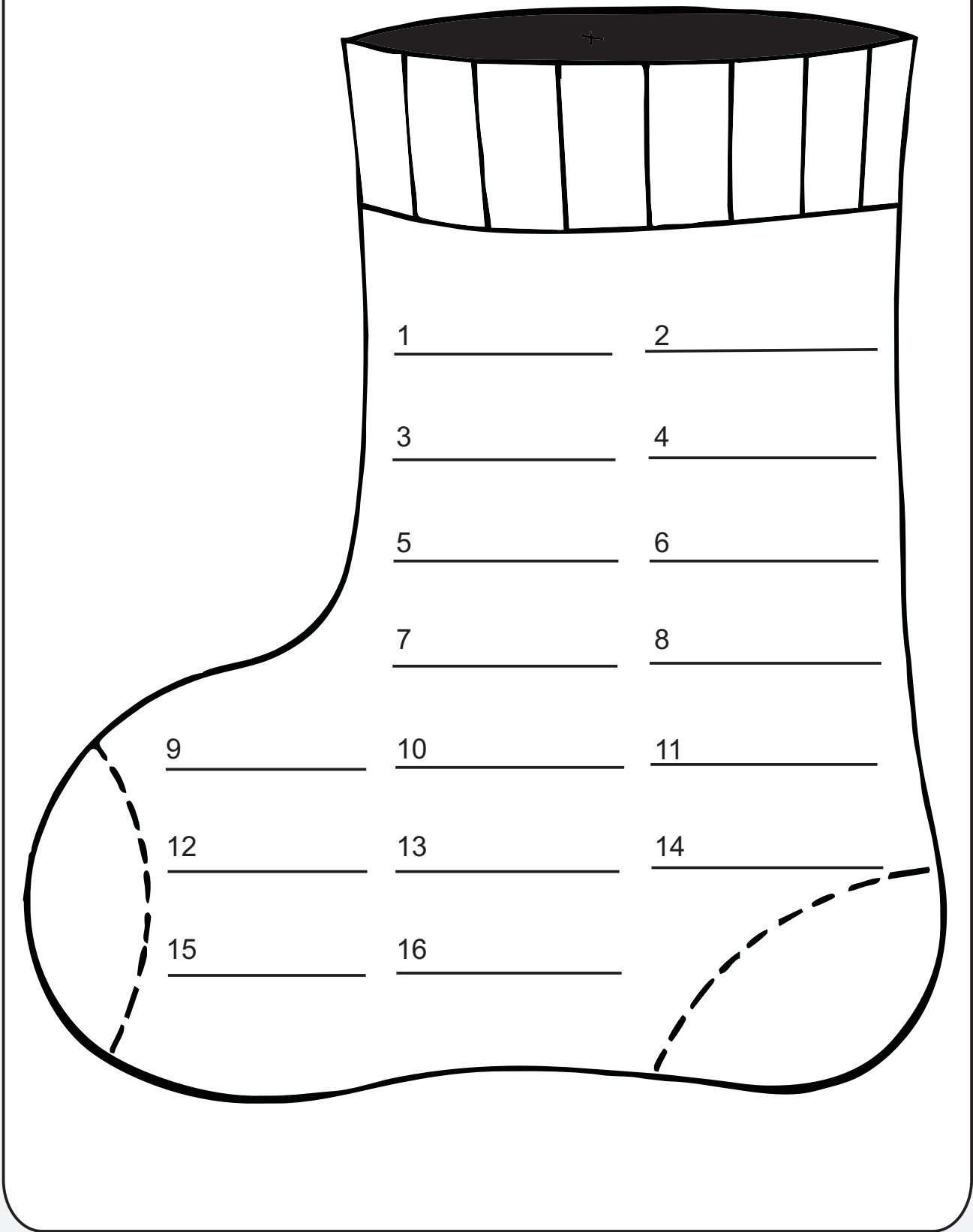

C b v H a B q A C u z m O X











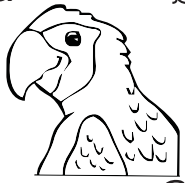



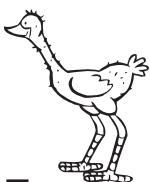

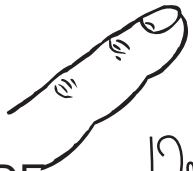









FICHAS PARA RECORTAR E FORMAR PALAVRAS

A	BA	CA	DA	FA
E	BE	/	DE	FE
I	BI	/	DI	FI
O	BO	CO	DO	FO
U	BU	CU	DU	FU
ÃO	BÃO	CÃO	DÃO	FÃO
A	BA	CA	DA	FA
E	BE	/	DE	FE
I	BI	/	DI	FI
O	BO	CO	DO	FO
U	BU	CU	DU	FU
ÃO	BÃO	CÃO	DÃO	FÃO

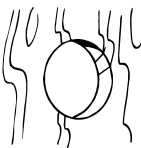











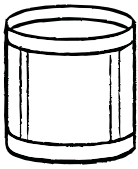
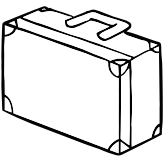

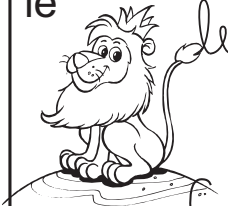

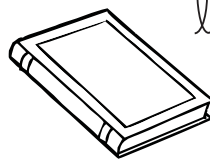
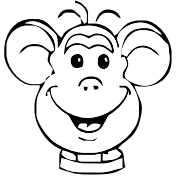
RECORTAR FICHAS PARA FORMAR PALAVRAS

GA	JA	LA	MA	A
/	JE	LE	ME	E
/	JI	LI	MI	I
GO	JO	LO	MO	O
GU	JU	LU	MU	U
GÃO	JÃO	LÃO	MÃO	ÃO
GA	JA	LA	MA	A
/	JE	LE	ME	E
/	JI	LI	MI	I
GO	JO	LO	MO	O
GU	JU	LU	MU	U
GÃO	JÃO	LÃO	MÃO	ÃO

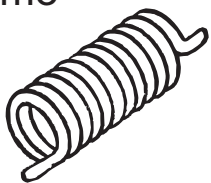
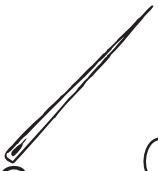
SILABÁRIO

<p>a a</p>  <p>A A</p>	<p>ba ba</p>  <p>BA Ba</p>	<p>ca ca</p>  <p>CA Ca</p>	<p>da da</p>  <p>DA Da</p>	<p>fa fa</p>  <p>FA Fa</p>
<p>e e</p>  <p>E E</p>	<p>be be</p>  <p>BE Be</p>	<p>/</p>	<p>de de</p>  <p>DE De</p>	<p>fe fe</p>  <p>FE Fe</p>
<p>i i</p>  <p>I I</p>	<p>bi bi</p>  <p>BI Bi</p>	<p>/</p>	<p>di di</p>  <p>DI Di</p>	<p>fi fi</p>  <p>FI Fi</p>
<p>o o</p>  <p>O O</p>	<p>bo bo</p>  <p>BO Bo</p>	<p>co co</p>  <p>CO Co</p>	<p>do do</p>  <p>DO Do</p>	<p>fo fo</p>  <p>FO Fo</p>
<p>u u</p>  <p>U U</p>	<p>bu bu</p>  <p>BU Bu</p>	<p>cu cu</p>  <p>CU Cu</p>	<p>du du</p>  <p>DU Du</p>	<p>fu fu</p>  <p>FU Fu</p>
<p>ão ão</p>  <p>ÃO ão</p>	<p>bão bão</p>  <p>BÃO bão</p>	<p>cão cão</p>  <p>CÃO cão</p>	<p>dão dão</p>  <p>DÃO dão</p>	<p>fão fão</p>  <p>FÃO fão</p>

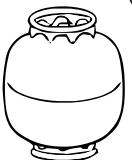
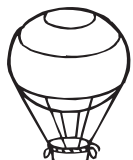
SILABÁRIO

<p>ga ga</p>  <p>Ga Ga</p>	<p>ja ja</p>  <p>Ja Ja</p>	<p>K</p>	<p>la la</p>  <p>La La</p>	<p>ma ma</p>  <p>Ma Ma</p>
<p>je je</p>  <p>Je Je</p>	<p>le le</p>  <p>Le Le</p>		<p>me me</p>  <p>Me Me</p>	
<p>ji ji</p>  <p>Ji Ji</p>	<p>li li</p>  <p>Li Li</p>		<p>mi mi</p>  <p>Mi Mi</p>	
<p>go go</p>  <p>Go Go</p>	<p>jo jo</p>  <p>Jo Jo</p>		<p>lo lo</p>  <p>Lo Lo</p>	<p>mo mo</p>  <p>Mo Mo</p>
<p>gu gu</p>  <p>Gu Gu</p>	<p>ju ju</p>  <p>Ju Ju</p>		<p>lu lu</p>  <p>Lu Lu</p>	<p>mu mu</p>  <p>Mu Mu</p>
<p>gão gão</p>  <p>Gão Gão</p>	<p>jão jão</p>  <p>Jão Jão</p>		<p>lão lão</p>  <p>Lão Lão</p>	<p>mão mão</p>  <p>Mão Mão</p>

